

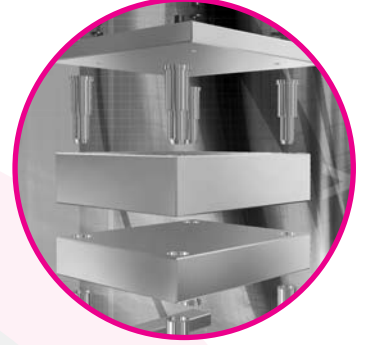

**OKSET®**

**Teknik Bilgi ve Ürün Katalođu**  
Technical Product Catalog

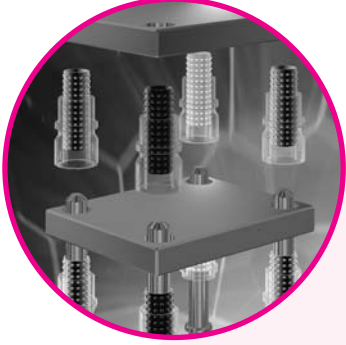



## ÖNSÖZ

Endüstrinin vazgeçilmez sektörlerinden biri olan kalıpcılık, günümüzde hem yan sanayiye hem de pazara sağladığı katkı sebebi ile önem ve itibar kazanmıştır. Ülkemizde ve Dünyada sürekli gelişmekte olan plastik, metal ve pres kalıp sektörünün ihtiyaçları, kalıp seti kullanımını gerekli hale getirmiştir.

İşi ve hedefi kalıp seti imal etmek olan firmamız, standart ve isteğe bağlı özel hazır setler üretmektedir. Hazır set üretiminde malzeme ve işçilik kalitesinden ödün vermeksizin, maliyeti ve zamanı en aza indirmek sureti ile, müşterilerimize kalite ve teslim süresi açısından en uygun çözümü sunma gayreti içerisindeyiz. Bu sebeple tezgahlarımız sürekli yenilenmekte, personelimiz eğitilmekte ve bilgi sektörünün imkanları kullanılarak üretim kalitemiz gün be gün arttırılmaktadır. Hali hazırda tekliften teslimata kadar imalatımız yazılım ve veritabanı ile eşgüdüm içerisinde yapılmaktadır. İleride müşterilerimizin de bu sürece katılıp takip edebilmesi için çalışmalarımız devam etmektedir.

Firmamız müşteri ihtiyaçlarını zamanında karşılayabilmek amacı ile çelik plaka (C 45), kolon, burç ve civata gibi kalıp seti elemanlarını stoklarında bulundurmaktadır. Aynı zamanda müşteri istekleri doğrultusunda alaşımli çelik kullanmakta ve isteğe bağlı (havuz, kanal, lokma gibi) özel işlemleri de yapmaktayız.

Hazırlamış olduğumuz bu teknik katalog sayesinde müşterilerimizle ortak bir dil oluşturabilmeyi hedefledik. Bu çalışmanın hazırlanması sürecinde bize yardımcı olan herkese teşekkür eder siz değerli müşterilerimizin takdirlerine sunarız.

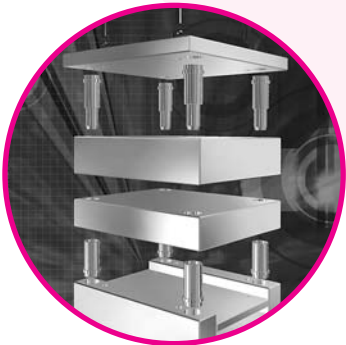

001 ÖNSÖZ

002-003 İÇİNDEKİLER

004-005 TOLERANS CETVELİ

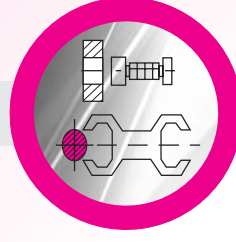

006-007

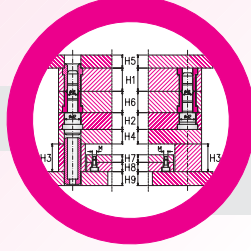

ENJEKSİYON KALIP SETİ  
KATALOG OKUMA KILAVUZU

008 TİPLERLE İLGİLİ AÇIKLAMA

009 EKS STANDART TİPLER

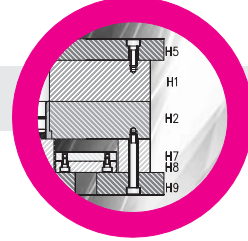

010-011

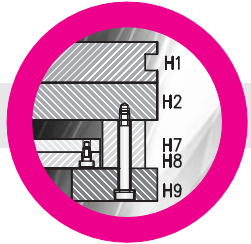

EKS ÖZEL TİPLER

012-037 eks E serisi

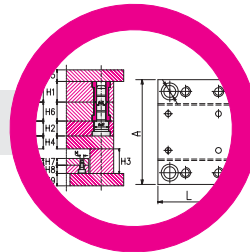

038-063

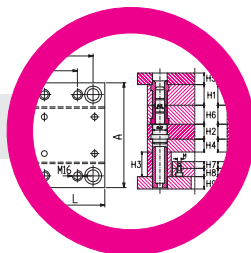

eks EK serisi

064-089 eks TE serisi

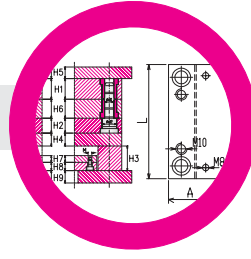

090-115 eks TEK serisi

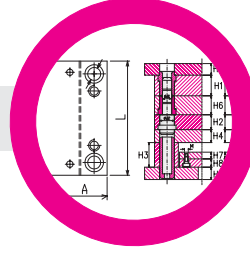

116-117

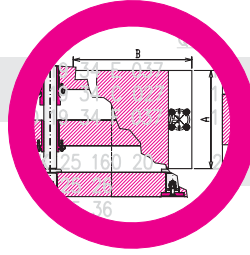

PRES KALIP SETLERİ  
KATALOG OKUMA KILAVUZU

118-131 PKS

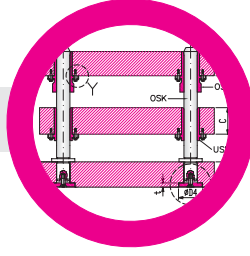

132-145

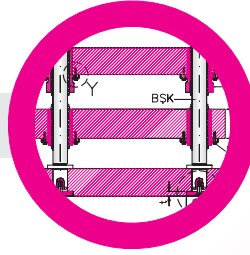

PKS BİLYALI

146

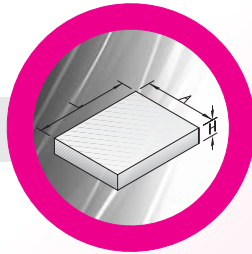

TAŞLANMIŞ PLAKALAR

147-152 KOLONLAR VE BURÇLAR

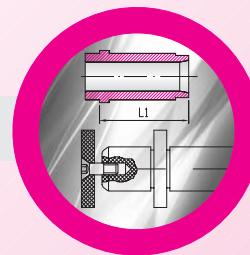



# İşleme Toleransları Machining Tolerances

## DIŞ ÖLÇÜLER

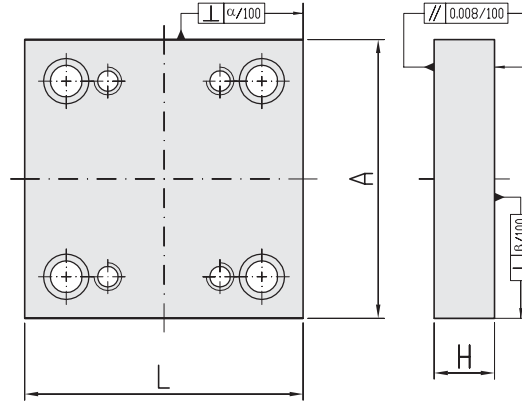

	Standart ölçü aralığı (A,L) Nominal dimension range [mm]	Tolerans Tolerance [ $\mu\text{m}$ ]
A , L	156...596	$\pm 20$
$\alpha/100$	156...596	8
$\beta/100$	156...596	8
H	14...127	+50/+150

## DELİK ÖLÇÜLERİ

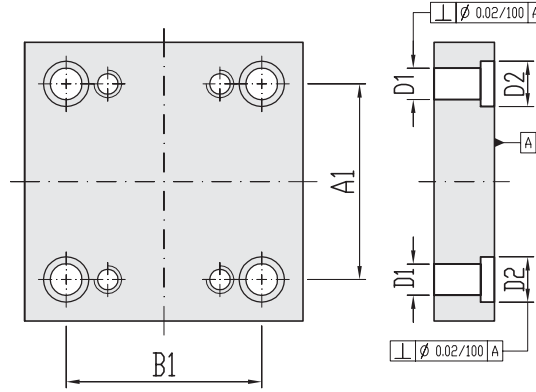

	Standart ölçü aralığı (A,L) Nominal dimension range [mm]	Tolerans Tolerance [ $\mu\text{m}$ ]
A1 , B1	80...120	$\pm 10$
	120...200	$\pm 12$
	200...250	$\pm 13$
	250...300	$\pm 15$
	300...400	$\pm 16$
	400...500	$\pm 17$
	500...600	$\pm 19$
D1	10...80	H7
D2	10...80	+500
t	3...18	+200



# Mil ve Delik Toleransları

## Tolerances for Holes and Shafts

### DELİK ÖLÇÜ TOLERANSI

Birim Delik Sistemi (Hole Basis Fit)

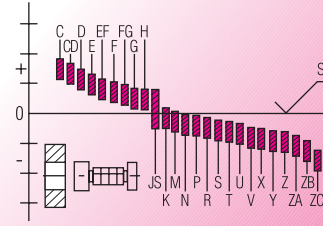

Örnek (Example)  
Ölçü (Normal Size)  
127 mm  
Tolerans Sembolü (Tolerance Symbol)  
F8 / f8

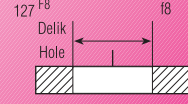

Ölçü (mm)	System	µm
Max. Ölçü Limiti	127,106	+106
Min. Ölçü Limiti	127,043	+43
Değer	0,063	63

	F6	F7	F8	G6	G7	H5	H6	H7	H8	H9	H10	H11	H12	H13	K6	K7	K8	JS6
3	+12	+16	+20	+8	+12	+4	+6	+10	+14	+25	+40	+60	+100	+140	0	0	0	+3
3 - 6	+18	+22	+28	+12	+16	+5	+8	+12	+18	+30	+48	+75	+120	+180	+2	+3	+5	+4
6 - 10	+22	+28	+35	+14	+20	+6	+9	+15	+22	+36	+58	+90	+150	+220	+2	+5	+9	+4.5
10 - 18	+27	+34	+43	+17	+24	+8	+11	+18	+27	+43	+70	+110	+180	+270	+2	+6	+8	+5.5
18 - 30	+33	+41	+53	+20	+28	+9	+13	+21	+33	+52	+84	+130	+210	+330	+2	+6	+10	+6.5
30 - 50	+41	+50	+64	+25	+34	+11	+16	+25	+39	+62	+100	+160	+250	+390	+3	+7	+12	+8
50 - 80	+49	+60	+76	+29	+40	+13	+19	+30	+46	+74	+120	+190	+300	+460	+4	+9	+14	+9.5
80 - 120	+58	+71	+90	+34	+47	+15	+22	+35	+54	+87	+140	+220	+350	+540	+4	+10	+16	+11
120 - 180	+68	+83	+106	+39	+54	+18	+25	+40	+63	+100	+160	+250	+400	+630	+4	+12	+20	+12.5
180 - 250	+79	+96	+122	+44	+61	+20	+29	+46	+72	+115	+185	+290	+460	+720	+5	+13	+22	+14.5
250 - 315	+88	+108	+137	+49	+69	+23	+32	+52	+81	+130	+210	+320	+520	+810	+5	+16	+25	+16
315 - 400	+98	+119	+151	+54	+75	+25	+36	+57	+89	+140	+230	+360	+570	+890	+4	+17	+28	+18
400 - 500	+108	+131	+165	+60	+83	+27	+40	+63	+97	+155	+250	+400	+630	+970	+8	+18	+29	+20

### MİL ÖLÇÜ TOLERANSI

Birim Mil Sistemi (Shaft Basis Fit)

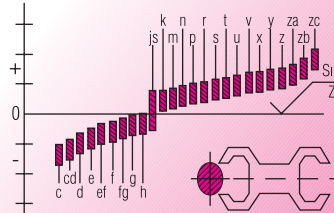

Örnek (Example)  
Ölçü (Normal Size)  
127 mm  
Tolerans Sembolü (Tolerance Symbol)  
F8 / f8

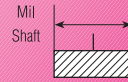

Ölçü (mm)	System	µm
Max. Ölçü Limiti	127,957	-43
Min. Ölçü Limiti	126,894	-106
Değer	0,063	63

	e6	e7	e8	f6	f7	f8	g5	g6	g7	h4	h5	h6	h7	h8	h9	h10	h11	js6
3	-14	-14	-14	-6	-6	-6	-2	-2	-2	0	0	0	0	0	0	0	0	+3
3 - 6	-20	-24	-28	-12	-16	-20	-6	-8	-12	-3	-4	-6	-10	-14	-25	-40	-60	-3
6 - 10	-25	-25	-25	-13	-13	-13	-5	-5	-5	0	0	0	0	0	0	0	0	+4.5
10 - 18	-32	-32	-32	-16	-16	-16	-6	-6	-6	0	0	0	0	0	0	0	0	+5.5
18 - 30	-40	-40	-40	-20	-20	-20	-7	-7	-7	0	0	0	0	0	0	0	0	+6.5
30 - 50	-50	-50	-50	-25	-25	-25	-9	-9	-9	0	0	0	0	0	0	0	0	+8
50 - 80	-60	-60	-60	-30	-30	-30	-10	-10	-10	0	0	0	0	0	0	0	0	+9.5
80 - 120	-72	-72	-72	-36	-36	-36	-12	-12	-12	0	0	0	0	0	0	0	0	+11
120 - 180	-85	-85	-85	-43	-43	-43	-14	-14	-14	0	0	0	0	0	0	0	0	+12.5
180 - 250	-100	-100	-100	-50	-50	-50	-15	-15	-15	0	0	0	0	0	0	0	0	+14.5
250 - 315	-110	-110	-110	-56	-56	-56	-17	-17	-17	0	0	0	0	0	0	0	0	+16
315 - 400	-125	-125	-125	-62	-62	-62	-18	-18	-18	0	0	0	0	0	0	0	0	+18
400 - 500	-135	-135	-135	-68	-68	-68	-20	-20	-20	0	0	0	0	0	0	0	0	+20



# Enjeksiyon Kalıp Setleri Katalog Okuma Kılavuzu

OKSET  
KALIP  
ELEMANLARI  
A.Ş.

## ENJEKSİYON KALIP SETİ TİPLERİ

E : ENJEKSİYON KALIP SETİ  
EK : KUYRUKLU KOLONLU ENJEKSİYON KALIP SETİ  
TE : TERS ENJEKSİYON KALIP SETİ  
TEK : KUYRUKLU KOLONLU TERS ENJEKSİYON KALIP SETİ

### PLAKA KODLAMASI ÖRNEĞİ :

ENJEKSİYON KALIP SETİ TİPİ (E/EK/TE/TEK) EK  
PLAKA ÖLÇÜLERİ (A) A=196  
PLAKA ÖLÇÜLERİ (L) L=396  
PLAKA İSMİ (H?) H1  
KALINLIK H=47

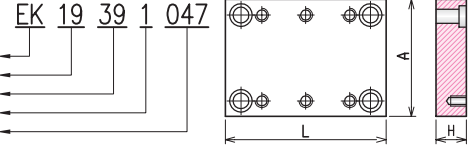

Yukarıda H1 örneklendirilerek bir plakanın nasıl kodlanacağı anlatılmaktadır. "EK" ifadesi "ENJEKSİYON KALIP SETİ TİPLERİ" başlığı altında belirtildiği üzere "KUYRUKLU KOLONLU ENJEKSİYON KALIP SETİ" ni temsil etmektedir. 19 39; plaka boyutlarının standart 196 x 396 olduğunu anlatmaktadır. 1 H1 plakası olduğunu göstermektedir. 047 ise plaka kalınlığını ifade etmektedir. Benzer şekilde kalıp seti içindeki tüm plakalar kodlanarak kalıp seti siparişi verilir. Bunun bir örneği aşağıda sunulmaktadır.

### RESİMDEKİ SETİN PLAKA TANIMLAMASI ÖRNEĞİ :

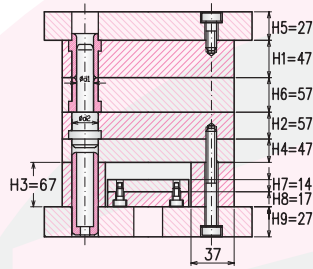

Plaka	Kodlama	Adet
H1	→ EK 19 39 1 047	1
H2	→ EK 19 39 2 057	1
H3	→ EK 19 39 3 067-037	2
H4	→ EK 19 39 4 047	1
H5	→ EK 19 39 5 027	1
H6	→ EK 19 39 6 057	1
H7	→ EK 19 39 7 014	1
H8	→ EK 19 39 8 017	1
H9	→ EK 19 39 9 027	1
<b>Elemanlar</b>		
KSKK	→ KSKK 20 56 106	4
KSB	→ KSB 20 46	4
SB	→ SB 20 56	4
DTP	→ DTP 20 100	4
M10	→ M10 150	6
M10	→ M10 30	6
M8	→ M8 20	6

Yukarıdaki örnekte görüleceği üzere plakalar seçildikten sonra istenen serinin standartlarına uygun olarak kolon, burç ve civatalar katalogdaki ilgili sayfalardan seçilir. Kolon, burç ve civatanın kodlanması örnekte görüldüğü gibi, sipariş için gerekli ölçülerin yan yana yazılması ile yapılır.

## Reading Guide for Injection Mold Base Catalog

### TYPE'S OF INJECTION MOLD BASE

E : INJECTION MOLD BASE  
EK : INJECTION MOLD BASE WITH TAILED GUIDE PILLAR  
TE : REVERSE INJECTION MOLD BASE  
TEK : REVERSE I.M.B. WITH TAILED GUIDE PILLAR

### PLATE CODING EXAMPLE :

TYPE OF INJECTION MOLD BASE (E/EK/TE/TEK) EK  
PLATE DIMENSIONS (A) A=196  
PLATE DIMENSIONS (L) L=396  
PLATE NAME (H?) H1  
THICKNESS H=47

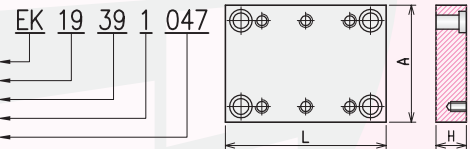

With resembling H1 label it is explained that how to code a plate. "EK" means that it is a part of Injection Mold Base with Locating Guide Pillar as seen in the related part of catalog. 19 39; tells us that plate dimensions are standart 196 mm by 396 mm. 1 Means "H1" plate and 037 is plate thickness. Mold base order should be made by coding each plate similarly. There is an example for this below.

### CODING SAMPLE OF THE MOLD BASE BELOW :

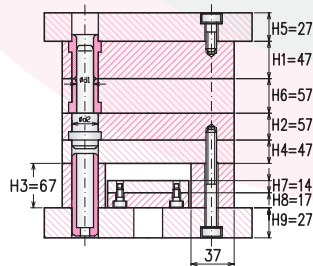

Plate	Coding	Quantity
H1	→ EK 19 39 1 047	1
H2	→ EK 19 39 2 057	1
H3	→ EK 19 39 3 067-037	2
H4	→ EK 19 39 4 047	1
H5	→ EK 19 39 5 027	1
H6	→ EK 19 39 6 057	1
H7	→ EK 19 39 7 014	1
H8	→ EK 19 39 8 017	1
H9	→ EK 19 39 9 027	1
<b>Items</b>		
KSKK	→ KSKK 20 56 106	4
KSB	→ KSB 20 46	4
SB	→ SB 20 56	4
DTP	→ DTP 20 100	4
M10	→ M10 150	6
M10	→ M10 30	6
M8	→ M8 20	6

As seen in the example above, after the plates and related dimensions are choosen; pillars, bushes, and screws of the desired mold base can be selected from the related page of catalog including standart dimensions. Coding of the pillars, bushes and screws can be done by writing related dimensions one after the other.





# Enjeksiyon Kalıp Setleri Katalog Okuma Kılavuzu

## Reading Guide for Injection Mold Base Catalog

Yan sayfada plaka kodlanması yapılmış olan EK 1939 (Kuyruklu kolonlu enjeksiyon kalıp seti) örneğinin katalogtaki ilgili sayfası aşağıdaki gibidir. Kalıp setlerini oluşturan elemanların nasıl seçileceği ve kodlanacağı aşağıda örneklenerek anlatılmıştır.

Sample page related with the EK 1939 (Injection mold base with locating guide pillars) on catalog, whose plate coding is defined on the previous page, is as follows. It is defined that how to chose and code items of the mold base by sampling.



### Enjeksiyon Kalıp 196 serisi

#### 196 series of Injection Mold Base

e  
196

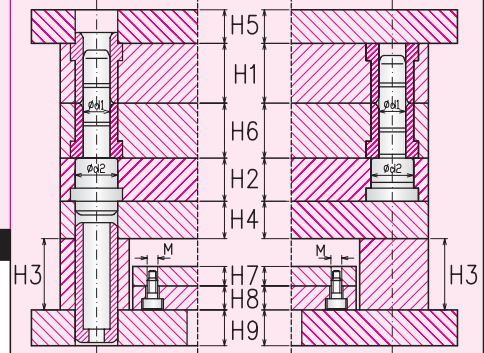
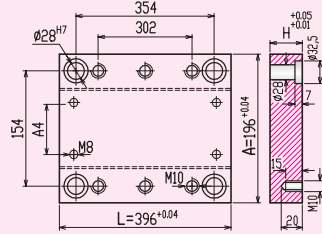

KUYRUKLU SET  
I.M.B. WITH TAILED GUIDE PILLAR

KUYRUKSUZ SET  
INJECTION MOLD BASE

#### KOLONLAR / PILLARS

S	K	L2																		
		d1	d2	d3	a	L1	26	36	46	56	66	76	86	96	106	116	126	136	146	
ød1 <sup>g6</sup>		26	36	46	56	66	76	86	96	106	116	126	136	146						
ød2 <sup>h7</sup>		16	24	28	6															
ød3 <sup>h7</sup>		20	28	32	6															

K	S	K	K	L2																
				d1	d2	d3	a	L1	26	36	46	56	66	76	86	96	106	116	126	136
ød1 <sup>g6</sup>				26	36	46	56	66	76	86	96	106	116	126	136	146				
ød2 <sup>h7</sup>				16	24	28	6													
ød3 <sup>h7</sup>				20	28	32	6													

#### BURÇLAR / GUIDE BUSHES

K	S	B	L												
			d1	d2	d3	a	26	36	46	56	66	76	86	96	
ød1 <sup>h7</sup>			16	24	28	6									
ød2 <sup>h7</sup>			20	28	32	6									

S	B	L											
		d1	d2	d3	a	26	36	46	56	66	76	86	96
ød1 <sup>h7</sup>		16	24	28	6								
ød2 <sup>h7</sup>		20	28	32	6								

D	T	B	L									
			d1	d2	M	60	80	100	120	140	160	
ød1 <sup>h7</sup>			16	24	M8							
ød2 <sup>h7</sup>			20	28	M8							

#### ÇİVATALAR/SCREWS

Ø	L	M																								
		20	25	30	35	40	45	50	60	70	80	90	100	110	120	130	140	150	160	180	200	220	240	260	280	
M8																										
M10																										

#### YAYLI RONDELA/SPRING WASHER

h <sub>max</sub>	d <sub>1</sub>	d <sub>2</sub>	d	s	
					5.9
ød1 <sup>h7</sup>					
ød2 <sup>h7</sup>					

EK 19 39 1 047

EK 19 39 2 057

EK 19 39 6 057

EK 19 39 4 047

EK 19 39 3 067  
- 037

EK 19 39 5 027

EK 19 39 9 027

EK 19 39 7 014

EK 19 39 8 017

KSKK 20 56 106

KSB 20 46

SB 20 56

DTP 20 100



**STANDART MALZEMELER, PLAKA ÖLÇÜLERİ ve İŞLEMLER**

STANDART MALZEMELER	STANDART ÖLÇÜLER			STANDART İŞLEMLER
	A	L	h	
1730 (C45)	156	156	14	Burç yeri
	196	196	17	Pim yeri
	246	246	27	Cıvata dış
	296	296	37	Cıvata boş
	346	346	47	Mil deliği
	396	396	57	Cıvata kafa yeri
	446	446	67	
	496	496	77	
		546	87	
		596	97	
			107	
			117	
			127	

**İSTEĞE BAĞLI MALZEMELER, PLAKA ÖLÇÜLERİ ve İŞLEMLER**

İSTEĞE BAĞLI MALZEMELER	İSTEĞE BAĞLI ÖLÇÜLER			İSTEĞE BAĞLI İŞLEMLER
	A	L	h	
2738				Temiz havuz
2312				Kaba kanal
2344				Kaba havuz
2379				Temiz kanal
2842				Lokma
2083	156	156	17	Boş delik
v.b.	157	157	18	Tesbit pimi
				Konik kilitleme
	...	...	...	Geri vurucu
	859	1499	249	Flanş yeri
	860	1500	250	Rulman
				Ocak yeri
				Kaba lokma
				Özel pim yeri
				Özel burç yeri
				Kilitleme
				İtici plaka kolon - burç



## Enjeksiyon Kalıp Seti Tipleri Injection Mold Base Types

### TİP 1 A

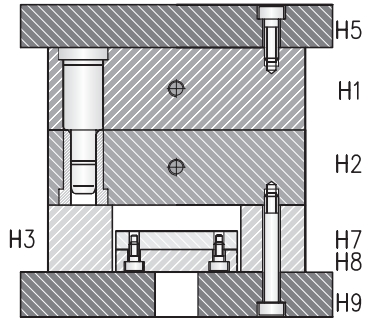

### TİP 2 A

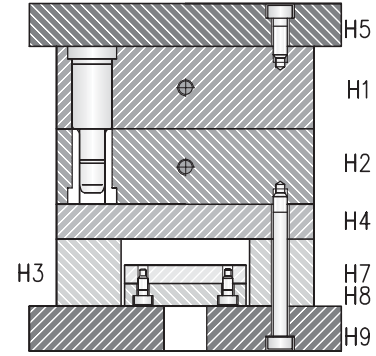

### TİP 3 A

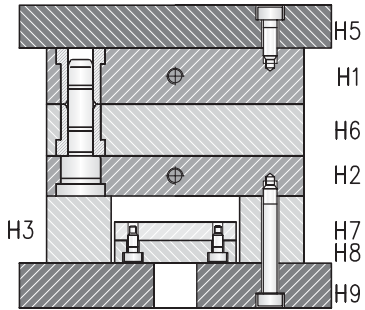

### TİP 4 A

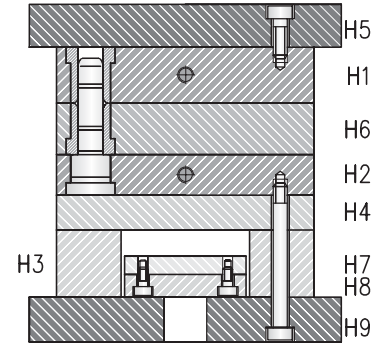

## Kuyruklu Elemanlarla Teşkil Edilmiş Enjeksiyon Kalıp Seti Tipleri Injection Mold Base Types Assembled with Locating Pillar

### TİP 5 A

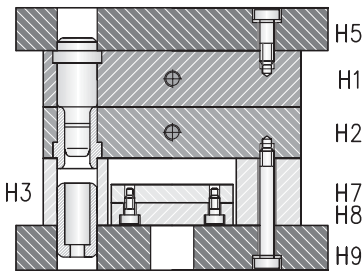

### TİP 6 A

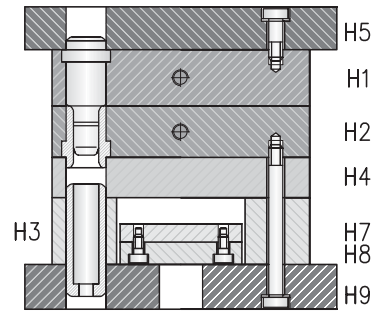

### TİP 7 A

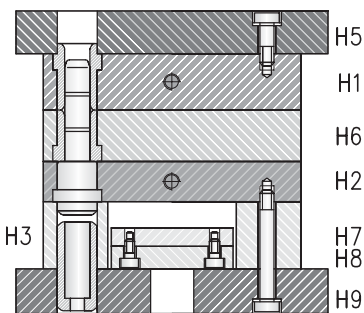

### TİP 8 A

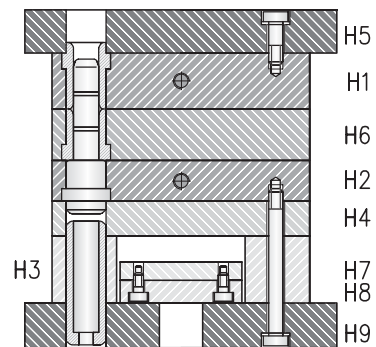



# Özel Enjeksiyon Kalıp Seti Tipleri

## Custom Injection Mold Base Types

	TİP 1	TİP 2	TİP 3	TİP 4
B	<p>H3 H5 H1 H2 H7 H8 H9</p>	<p>H3 H5 H1 H2 H4 H7 H8 H9</p>	<p>H3 H5 H1 H6 H2 H7 H8 H9</p>	<p>H3 H5 H1 H6 H2 H4 H7 H8 H9</p>
C	<p>H3 H5 H1 H2 H7 H8 H9</p>	<p>H3 H5 H1 H2 H4 H7 H8 H9</p>	<p>H3 H5 H1 H6 H2 H7 H8 H9</p>	<p>H3 H5 H1 H6 H2 H4 H7 H8 H9</p>
D	<p>H3 H1 H2 H7 H8 H9</p>	<p>H3 H1 H2 H4 H7 H8 H9</p>	<p>H3 H1 H6 H2 H7 H8 H9</p>	<p>H3 H1 H6 H2 H4 H7 H8 H9</p>
E	<p>H3 H1 H2 H7 H8 H9</p>	<p>H3 H1 H2 H4 H7 H8 H9</p>	<p>H3 H1 H6 H2 H7 H8 H9</p>	<p>H3 H1 H6 H2 H4 H7 H8 H9</p>
F	<p>H5 H1 H2 H9</p>	<p>H5 H1 H2 H4 H9</p>	<p>H5 H1 H6 H2 H9</p>	<p>H5 H1 H6 H2 H4 H9</p>
G	<p>H3 H1 H2 H7 H8 H9</p>	<p>H3 H1 H2 H4 H7 H8 H9</p>	<p>H3 H1 H6 H2 H7 H8 H9</p>	<p>H3 H1 H6 H2 H4 H7 H8 H9</p>



# Kuyruklu Elemanlarla Teşkil Edilmiş Özel Enjeksiyon Kalıp Seti Tipleri

## Custom Injection Mold Base Types Assembled with Locating Pillar

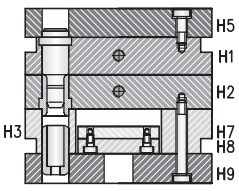
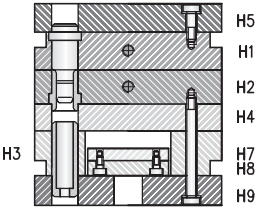
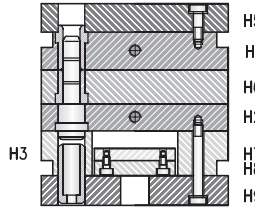
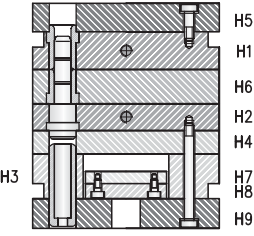
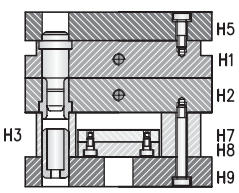
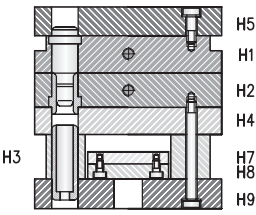
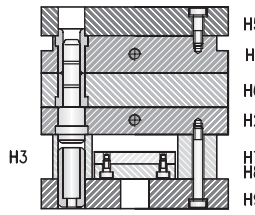
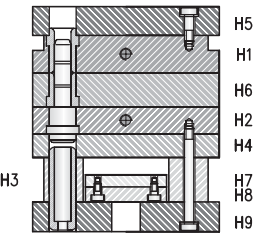
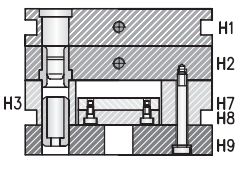
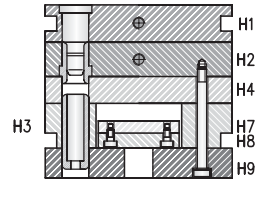
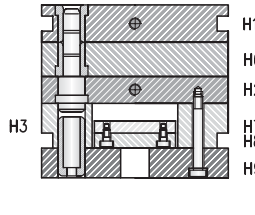
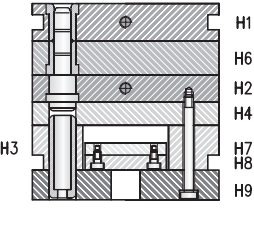
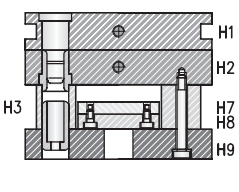
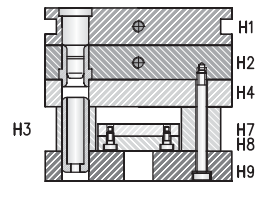
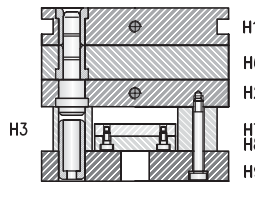
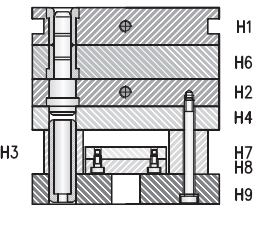
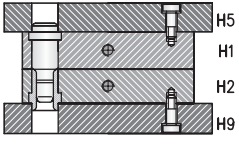
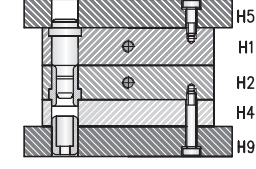
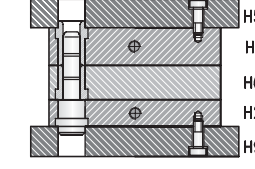
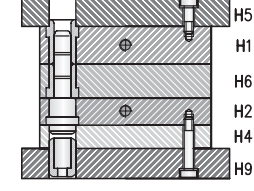
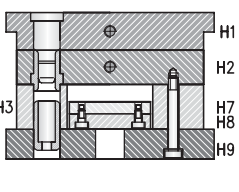
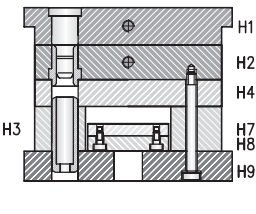
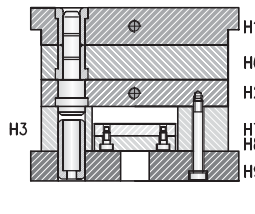
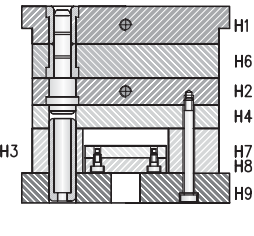
	TİP 5	TİP 6	TİP 7	TİP 8
B				
C				
D				
E				
F				
G				

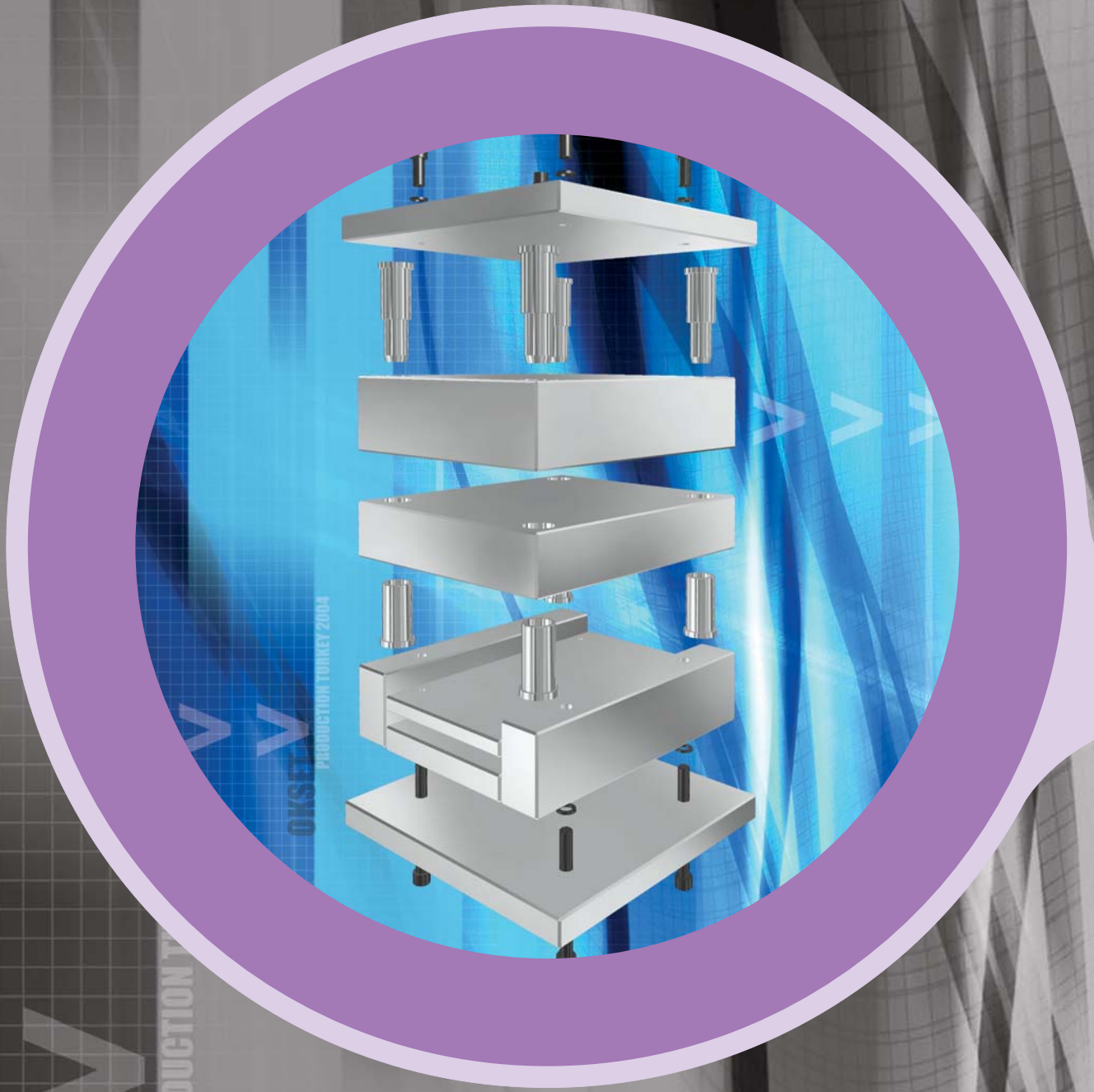

**OKSEF**

PRODUCTION T

OKSEF  
PRODUCTION TURKEY 2004

# Enjeksiyon Kalıp Seti Injection Mold Base

EKS E Serisi

e

serisi / series



 **OKSET**®





# Enjeksiyon Kalıp Seti 156 Serisi

## 156 Series of Injection Mold Base

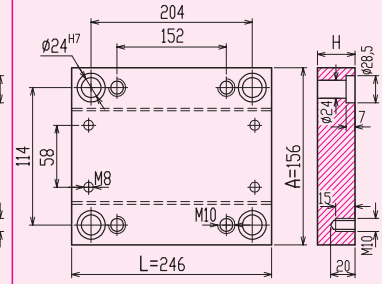
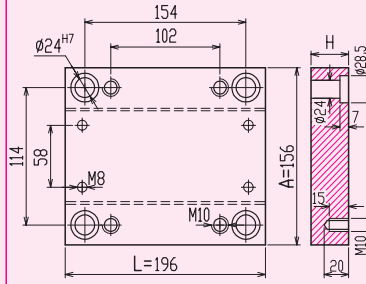
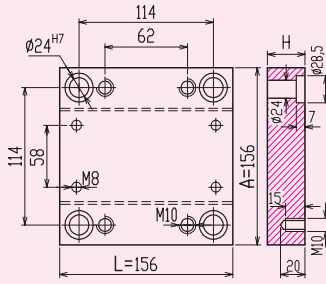
e  
156

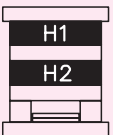
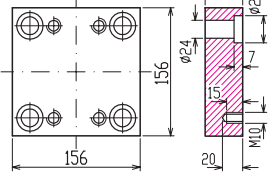
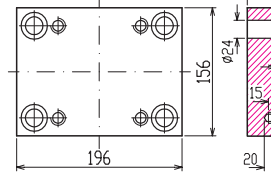
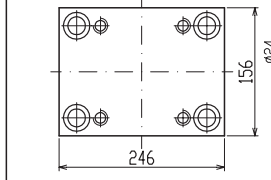
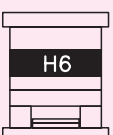
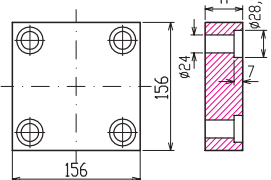
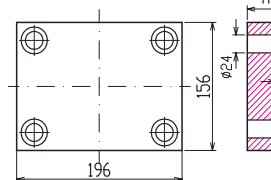
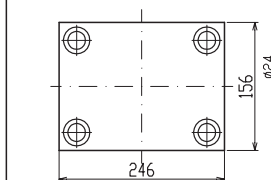
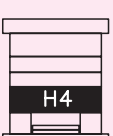
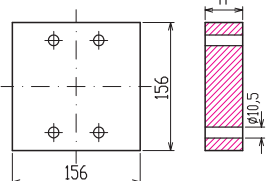
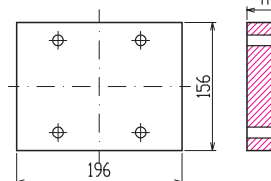
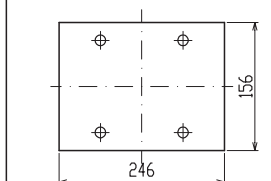
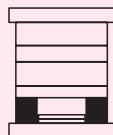
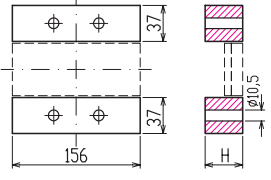
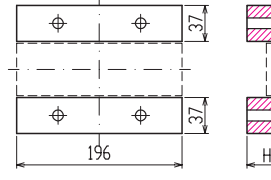
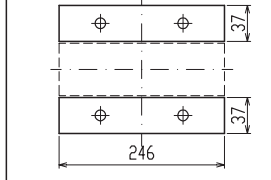
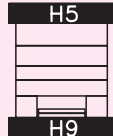
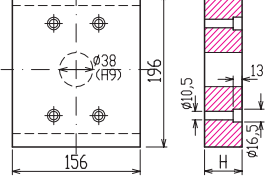
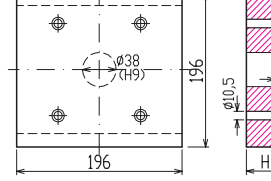
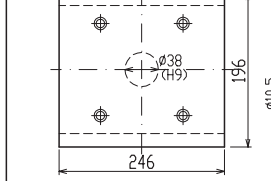
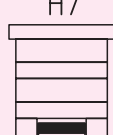
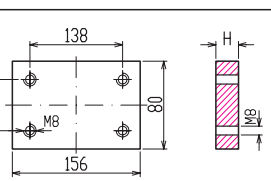
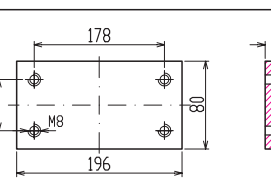
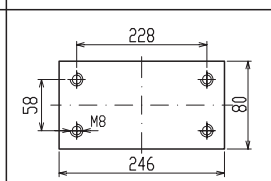

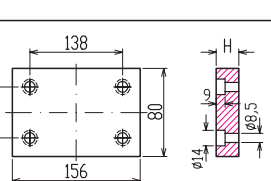
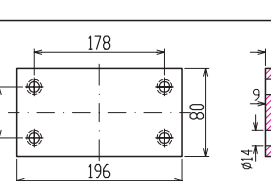
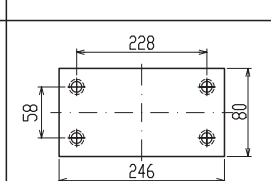
Plakalar / Plates	H	E1515	E1519	E1524
 H1-H2	27			
	37			
	47			
	57			
	67			
	77			
 H6	27			
	37			
	47			
	57			
	67			
	77			
 H4	27			
	37			
	47			
 H3	57			
	67			
	77			
 H5-H9	27			
	27			
 H7	14			
	17			
 H8	14			
	17			





# Enjeksiyon Kalıp Seti 156 Serisi

## 156 Series of Injection Mold Base

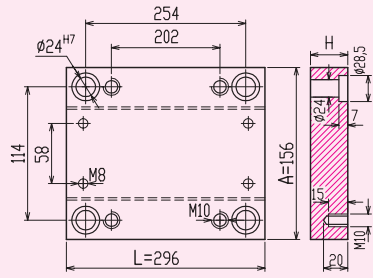

E1529

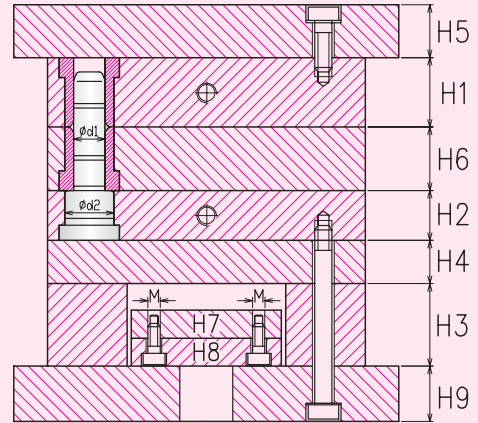
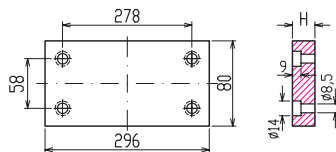
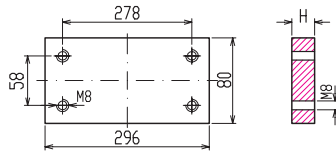
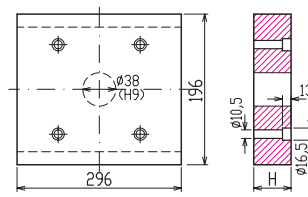
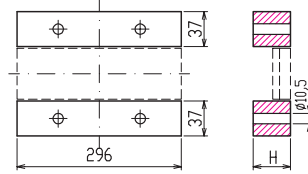
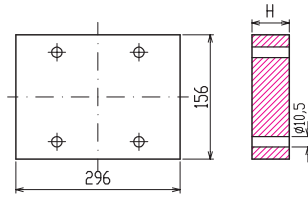
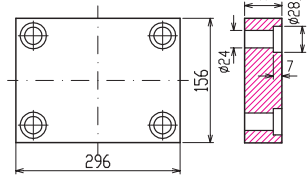
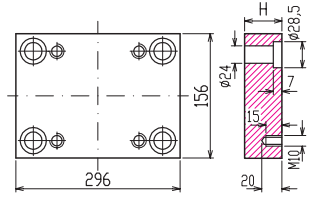

KOLONLAR / PILLARS

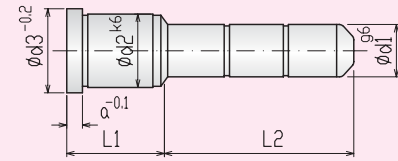

S K K			L2											
d1	d2	d3	$\alpha$	L1	26	36	46	56	66	76	86	96	106	116
16	24	28	6	26	36	46	56	66	76	86	96	106	116	

BURÇLAR / GUIDE BUSHES

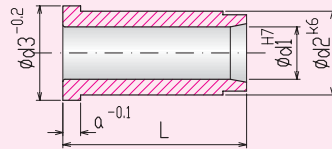

S B			L							
d1	d2	d3	$\alpha$	26	36	46	56	66	76	86
16	24	28	6							

ÇİVATALAR / SOCKET CAP SCREWS

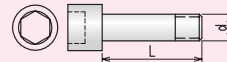

DIN 912 12.9

$d$	L	25	30	35	40	45	50	60	70	80	90	100	110	120	130	140	150	160	180	200	220	240	260	280	
M8																									
M10																									

YAYLI RONDELA / SPRING WASHER

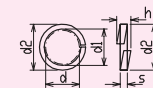

$h_{max}$	$d_1$	$d_2$	$d$	$s$
5.9	10.2	16	10	2.5



# Enjeksiyon Kalıp Seti 196 Serisi

## 196 Series of Injection Mold Base

e  
196

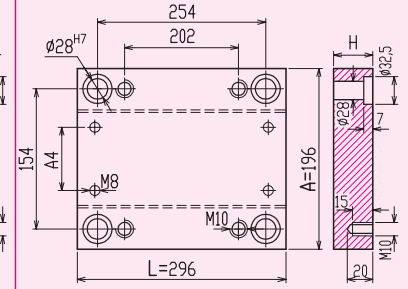
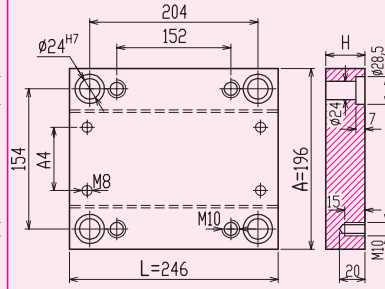
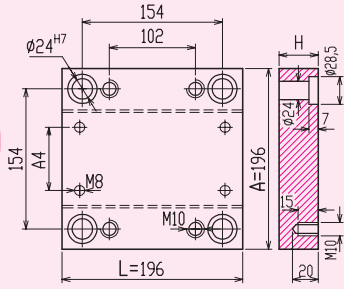

Plakalar / Plates	H	E1919	E1924	E1929																													
<b>H1-H2</b> 	27																																
	37																																
	47																																
	57																																
	67																																
	87																																
<b>H6</b> 	27																																
	37																																
	47																																
	57																																
	67																																
	87																																
<b>H4</b> 	27																																
	37																																
	47																																
<b>H3</b> 	57																																
	67																																
	77																																
<b>H5-H9</b> 	27																																
	37																																
<b>H7</b> 	14																																
	17																																
	<table border="1"> <tr><td>A5</td><td>A3</td><td>A4</td></tr> <tr><td>37</td><td>120</td><td>98</td></tr> <tr><td>47</td><td>100</td><td>78</td></tr> </table>				A5	A3	A4	37	120	98	47	100	78	<table border="1"> <tr><td>A5</td><td>A3</td><td>A4</td></tr> <tr><td>37</td><td>120</td><td>98</td></tr> <tr><td>47</td><td>100</td><td>78</td></tr> </table>	A5	A3	A4	37	120	98	47	100	78	<table border="1"> <tr><td>A5</td><td>A3</td><td>A4</td></tr> <tr><td>37</td><td>120</td><td>98</td></tr> <tr><td>47</td><td>100</td><td>78</td></tr> </table>	A5	A3	A4	37	120	98	47	100	78
A5	A3	A4																															
37	120	98																															
47	100	78																															
A5	A3	A4																															
37	120	98																															
47	100	78																															
A5	A3	A4																															
37	120	98																															
47	100	78																															
<b>H8</b> 	17																																
	<table border="1"> <tr><td>A5</td><td>A3</td><td>A4</td></tr> <tr><td>37</td><td>120</td><td>98</td></tr> <tr><td>47</td><td>100</td><td>78</td></tr> </table>				A5	A3	A4	37	120	98	47	100	78	<table border="1"> <tr><td>A5</td><td>A3</td><td>A4</td></tr> <tr><td>37</td><td>120</td><td>98</td></tr> <tr><td>47</td><td>100</td><td>78</td></tr> </table>	A5	A3	A4	37	120	98	47	100	78	<table border="1"> <tr><td>A5</td><td>A3</td><td>A4</td></tr> <tr><td>37</td><td>120</td><td>98</td></tr> <tr><td>47</td><td>100</td><td>78</td></tr> </table>	A5	A3	A4	37	120	98	47	100	78
	A5				A3	A4																											
37	120	98																															
47	100	78																															
A5	A3	A4																															
37	120	98																															
47	100	78																															
A5	A3	A4																															
37	120	98																															
47	100	78																															
<table border="1"> <tr><td>A5</td><td>A3</td><td>A4</td></tr> <tr><td>37</td><td>120</td><td>98</td></tr> <tr><td>47</td><td>100</td><td>78</td></tr> </table>	A5	A3	A4	37	120	98	47	100	78	<table border="1"> <tr><td>A5</td><td>A3</td><td>A4</td></tr> <tr><td>37</td><td>120</td><td>98</td></tr> <tr><td>47</td><td>100</td><td>78</td></tr> </table>	A5	A3	A4	37	120	98	47	100	78	<table border="1"> <tr><td>A5</td><td>A3</td><td>A4</td></tr> <tr><td>37</td><td>120</td><td>98</td></tr> <tr><td>47</td><td>100</td><td>78</td></tr> </table>	A5	A3	A4	37	120	98	47	100	78				
A5	A3	A4																															
37	120	98																															
47	100	78																															
A5	A3	A4																															
37	120	98																															
47	100	78																															
A5	A3	A4																															
37	120	98																															
47	100	78																															



# Enjeksiyon Kalıp Seti 196 Serisi

## 196 Series of Injection Mold Base

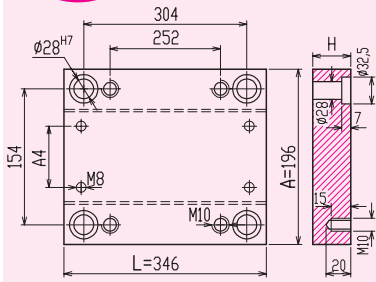

E1934

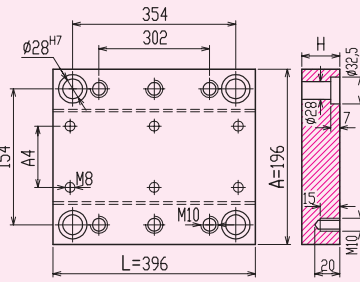

E1939

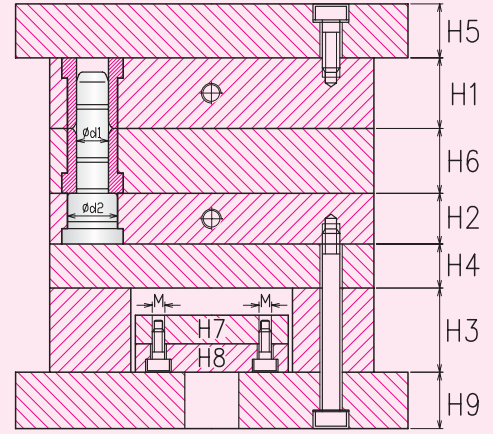
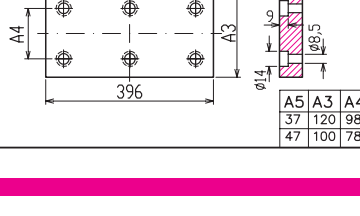
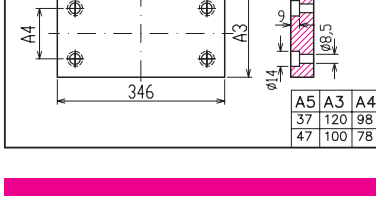
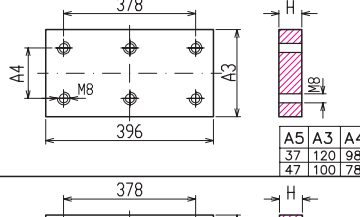
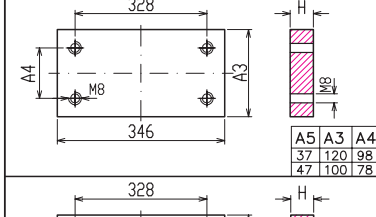
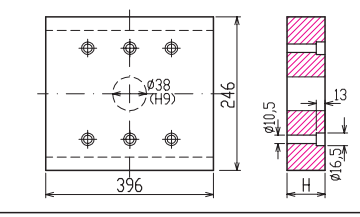
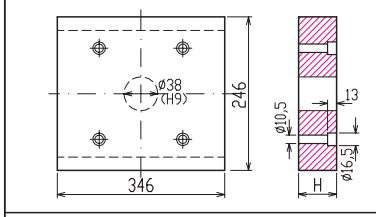
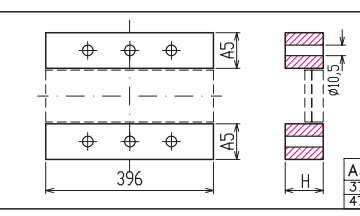
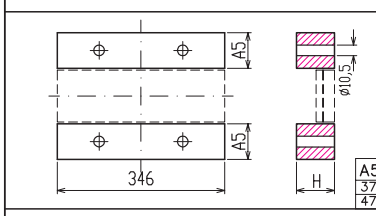
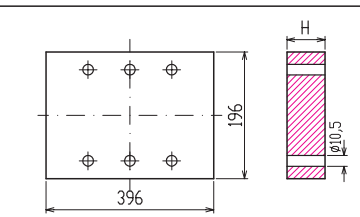
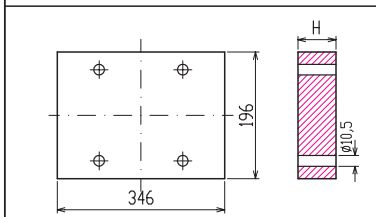
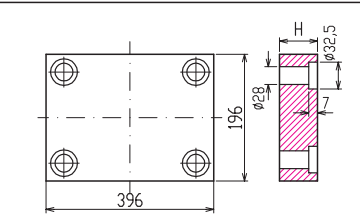
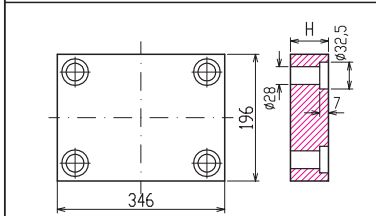
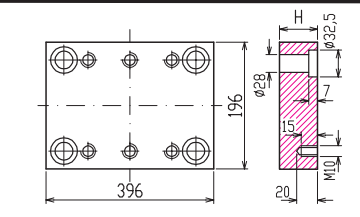
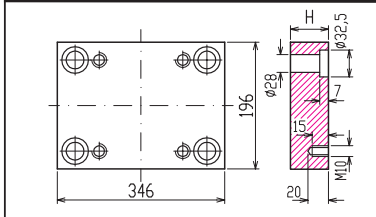

### KOLONLAR / PILLARS

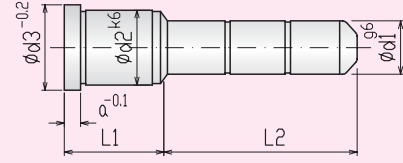

S K K			L2																	
d1	d2	d3	a	L1	26	36	46	56	66	76	86	96	106	116	126	136	146			
16	24	28	6	26																
				36																
				46																
				56																
				66																
				76																
20	28	32	6	26																
				36																
				46																
				56																
				66																
				76																

### BURÇLAR / GUIDE BUSHES

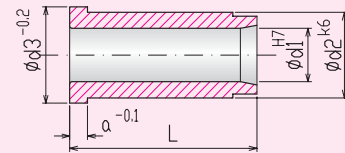

S B			L								
d1	d2	d3	a	26	36	46	56	66	76	86	96
16	24	28	6								
20	28	32	6								

### ÇİVATALAR / SOCKET CAP SCREWS

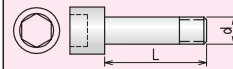

DIN 912 12.9

d	L	20	25	30	35	40	45	50	60	70	80	90	100	110	120	130	140	150	160	180	200	240	260	280	
M8																									
M10																									

### YAYLI RONDELA / SPRING WASHER

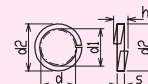

h <sub>max</sub>	d <sub>1</sub>	d <sub>2</sub>	d	s
5.9	10.2	16	10	2.5



# Enjeksiyon Kalıp Seti 246 Serisi

## 246 Series of Injection Mold Base

e  
246

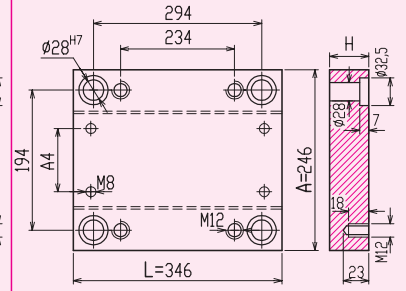
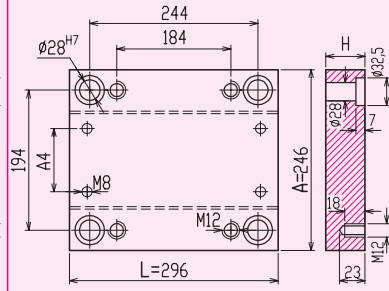
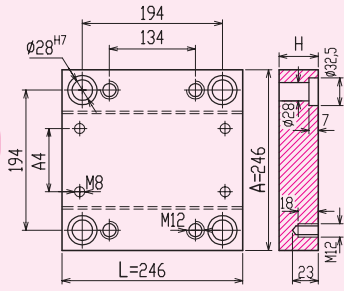

Plakalar / Plates	H	E2424	E2429	E2434																													
<b>H1-H2</b> 	27																																
	37																																
	47																																
	57																																
	67																																
	77																																
<b>H6</b> 	27																																
	37																																
	47																																
	57																																
	67																																
	77																																
<b>H4</b> 	27																																
	37																																
	47																																
<b>H3</b> 	57																																
	67																																
	77																																
	87																																
	97																																
<b>H5-H9</b> 	27																																
	37																																
<b>H7</b> 	14																																
	17																																
	<table border="1"> <tr><td>A5</td><td>A3</td><td>A4</td></tr> <tr><td>47</td><td>148</td><td>130</td></tr> <tr><td>57</td><td>128</td><td>110</td></tr> </table>				A5	A3	A4	47	148	130	57	128	110	<table border="1"> <tr><td>A5</td><td>A3</td><td>A4</td></tr> <tr><td>47</td><td>148</td><td>130</td></tr> <tr><td>57</td><td>128</td><td>110</td></tr> </table>	A5	A3	A4	47	148	130	57	128	110	<table border="1"> <tr><td>A5</td><td>A3</td><td>A4</td></tr> <tr><td>47</td><td>148</td><td>130</td></tr> <tr><td>57</td><td>128</td><td>110</td></tr> </table>	A5	A3	A4	47	148	130	57	128	110
A5	A3	A4																															
47	148	130																															
57	128	110																															
A5	A3	A4																															
47	148	130																															
57	128	110																															
A5	A3	A4																															
47	148	130																															
57	128	110																															
<b>H8</b> 	17																																
	<table border="1"> <tr><td>A5</td><td>A3</td><td>A4</td></tr> <tr><td>47</td><td>148</td><td>130</td></tr> <tr><td>57</td><td>128</td><td>110</td></tr> </table>				A5	A3	A4	47	148	130	57	128	110	<table border="1"> <tr><td>A5</td><td>A3</td><td>A4</td></tr> <tr><td>47</td><td>148</td><td>130</td></tr> <tr><td>57</td><td>128</td><td>110</td></tr> </table>	A5	A3	A4	47	148	130	57	128	110	<table border="1"> <tr><td>A5</td><td>A3</td><td>A4</td></tr> <tr><td>47</td><td>148</td><td>130</td></tr> <tr><td>57</td><td>128</td><td>110</td></tr> </table>	A5	A3	A4	47	148	130	57	128	110
	A5				A3	A4																											
47	148	130																															
57	128	110																															
A5	A3	A4																															
47	148	130																															
57	128	110																															
A5	A3	A4																															
47	148	130																															
57	128	110																															
<table border="1"> <tr><td>A5</td><td>A3</td><td>A4</td></tr> <tr><td>47</td><td>148</td><td>130</td></tr> <tr><td>57</td><td>128</td><td>110</td></tr> </table>	A5	A3	A4	47	148	130	57	128	110	<table border="1"> <tr><td>A5</td><td>A3</td><td>A4</td></tr> <tr><td>47</td><td>148</td><td>130</td></tr> <tr><td>57</td><td>128</td><td>110</td></tr> </table>	A5	A3	A4	47	148	130	57	128	110	<table border="1"> <tr><td>A5</td><td>A3</td><td>A4</td></tr> <tr><td>47</td><td>148</td><td>130</td></tr> <tr><td>57</td><td>128</td><td>110</td></tr> </table>	A5	A3	A4	47	148	130	57	128	110				
A5	A3	A4																															
47	148	130																															
57	128	110																															
A5	A3	A4																															
47	148	130																															
57	128	110																															
A5	A3	A4																															
47	148	130																															
57	128	110																															



# Enjeksiyon Kalıp Seti 246 Serisi 246 Series of Injection Mold Base

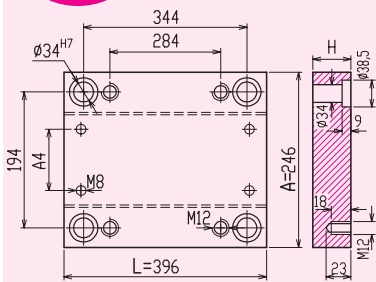

E2439

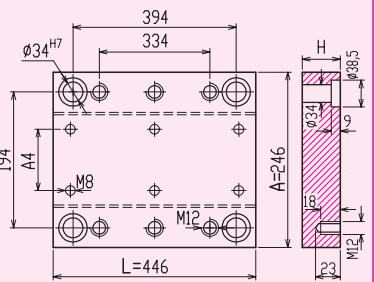
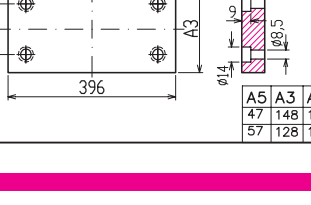
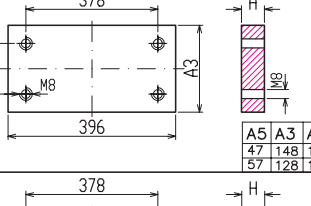
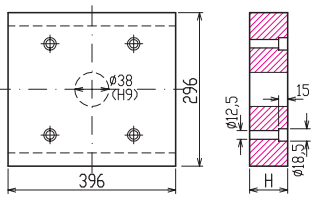
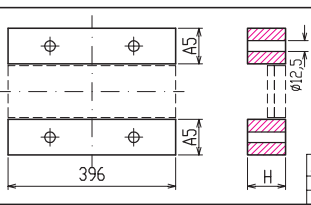
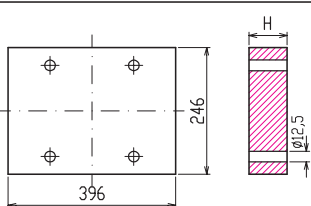
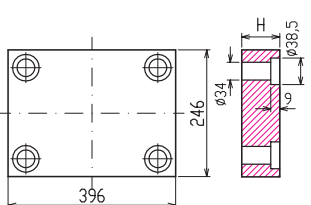
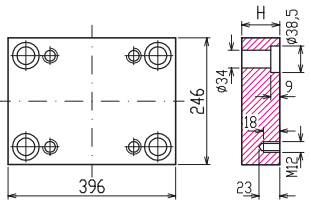

E2444

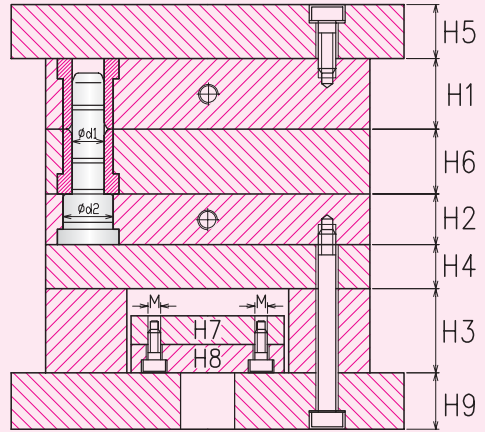
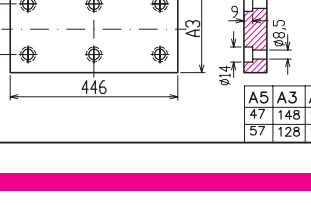
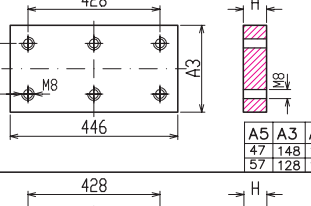
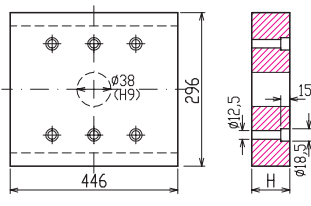
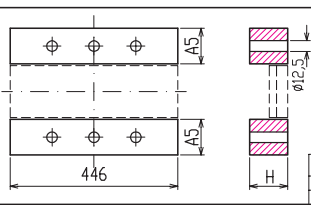
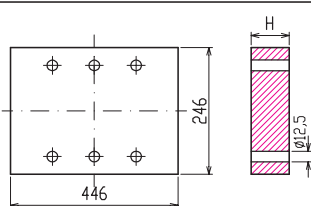
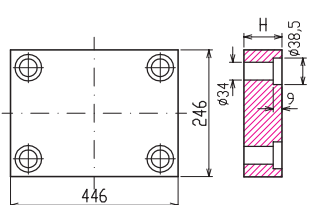
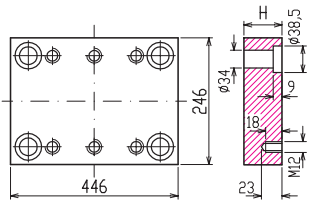

## KOLONLAR / PILLARS

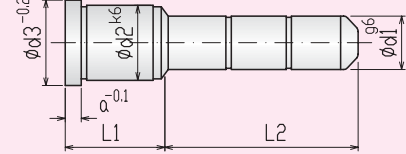

d1	d2	d3	a	L2												
				L1	26	36	46	56	66	76	86	96	106	116	126	136
20	28	32	6	26	36	46	56	66	76	86	96	106	116	126	136	146
				36	46	56	66	76	86	96	106	116	126	136	146	
				46	56	66	76	86	96	106	116	126	136	146		
				56	66	76	86	96	106	116	126	136	146			
				66	76	86	96	106	116	126	136	146				
				76	86	96	106	116	126	136	146					
				86	96	106	116	126	136	146						
25	34	38	8	26	36	46	56	66	76	86	96	106	116	126	136	146
				36	46	56	66	76	86	96	106	116	126	136	146	
				46	56	66	76	86	96	106	116	126	136	146		
				56	66	76	86	96	106	116	126	136	146			
				66	76	86	96	106	116	126	136	146				
				76	86	96	106	116	126	136	146					
				86	96	106	116	126	136	146						

## BURÇLAR / GUIDE BUSHES

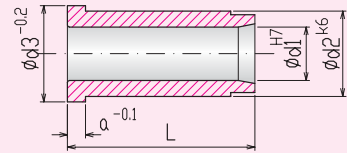

d1	d2	d3	a	L										
				26	36	46	56	66	76	86	96	106		
20	28	32	6											
25	34	38	8											

## ÇİVATALAR / SOCKET CAP SCREWS

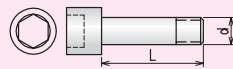

DIN 912 12.9

d	L	20	25	30	35	40	45	50	60	70	80	90	100	110	120	130	140	150	160	180	200	220	240	260	280	
M8																										
M12																										

## YAYLI RONDOLA / SPRING WASHER

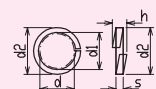

$h_{max}$	$d_1$	$d_2$	$d$	$s$
5.9	12.2	18	12	2.5



# Enjeksiyon Kalıp Seti 296 Serisi

## 296 Series of Injection Mold Base

e  
296

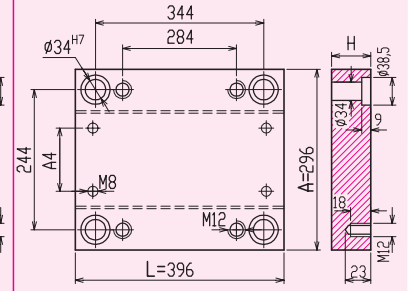
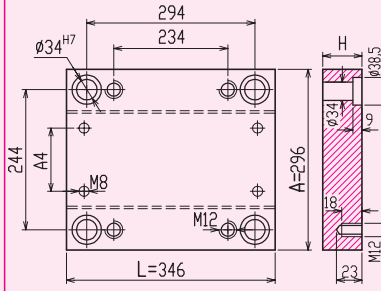
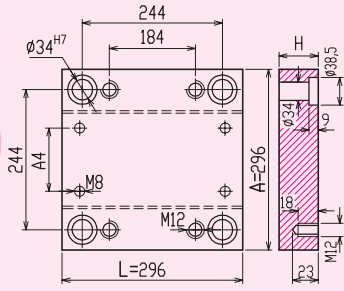

Plakalar / Plates	H	E2929	E2934	E2939												
<b>H1-H2</b> 	27															
	37															
	47															
	57															
	67															
	77															
	87															
<b>H6</b> 	27															
	37															
	47															
	57															
	67															
<b>H4</b> 	27															
	37															
	47															
	57															
<b>H3</b> 	57															
	67															
	77															
	87															
	97															
<b>H5-H9</b> 	27															
	37															
<b>H7</b> 	17															
	22															
	<table border="1"> <tr><td>A5</td><td>A3</td><td>A4</td></tr> <tr><td>47</td><td>198</td><td>180</td></tr> <tr><td>57</td><td>178</td><td>160</td></tr> </table>				A5	A3	A4	47	198	180	57	178	160			
	A5				A3	A4										
	47				198	180										
57	178	160														
<table border="1"> <tr><td>A5</td><td>A3</td><td>A4</td></tr> <tr><td>47</td><td>198</td><td>180</td></tr> <tr><td>57</td><td>178</td><td>160</td></tr> </table>	A5	A3	A4	47	198	180	57	178	160							
A5	A3	A4														
47	198	180														
57	178	160														
<table border="1"> <tr><td>A5</td><td>A3</td><td>A4</td></tr> <tr><td>47</td><td>198</td><td>180</td></tr> <tr><td>57</td><td>178</td><td>160</td></tr> </table>	A5	A3	A4	47	198	180	57	178	160							
A5	A3	A4														
47	198	180														
57	178	160														
<b>H8</b> 	22															
	<table border="1"> <tr><td>A5</td><td>A3</td><td>A4</td></tr> <tr><td>47</td><td>198</td><td>180</td></tr> <tr><td>57</td><td>178</td><td>160</td></tr> </table>				A5	A3	A4	47	198	180	57	178	160			
	A5				A3	A4										
	47				198	180										
	57				178	160										
<table border="1"> <tr><td>A5</td><td>A3</td><td>A4</td></tr> <tr><td>47</td><td>198</td><td>180</td></tr> <tr><td>57</td><td>178</td><td>160</td></tr> </table>	A5	A3	A4	47	198	180	57	178	160							
A5	A3	A4														
47	198	180														
57	178	160														
<table border="1"> <tr><td>A5</td><td>A3</td><td>A4</td></tr> <tr><td>47</td><td>198</td><td>180</td></tr> <tr><td>57</td><td>178</td><td>160</td></tr> </table>	A5	A3	A4	47	198	180	57	178	160							
A5	A3	A4														
47	198	180														
57	178	160														



# Enjeksiyon Kalıp Seti 296 Serisi 296 Series of Injection Mold Base

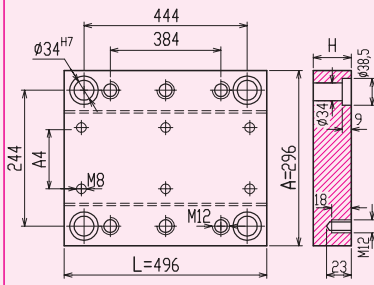
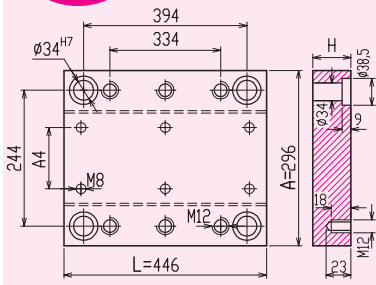

E2944

E2949

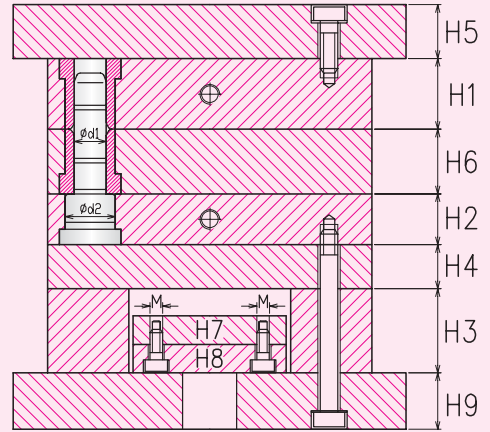
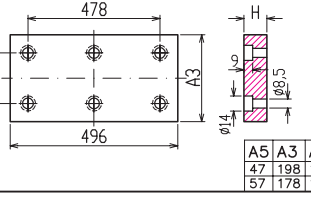
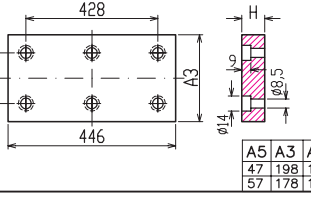
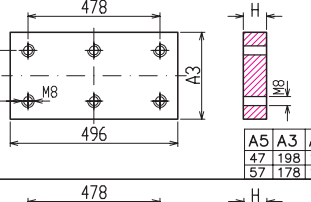
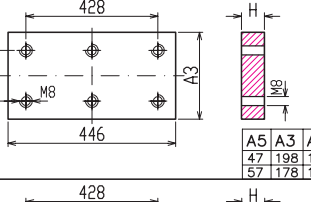
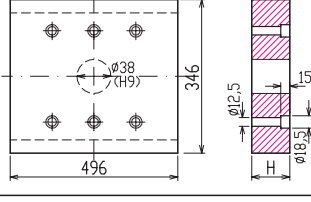
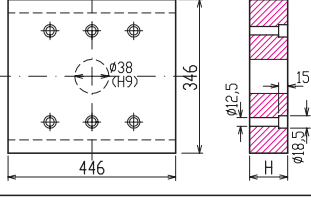
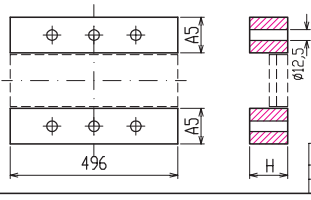
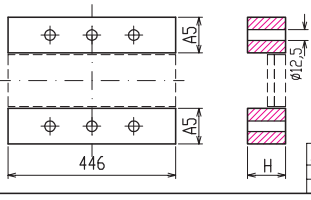
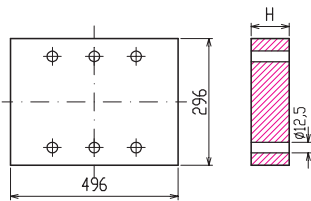
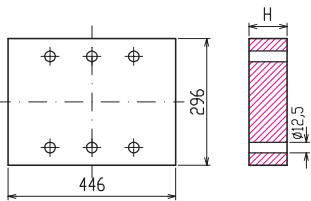
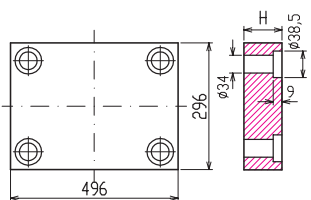
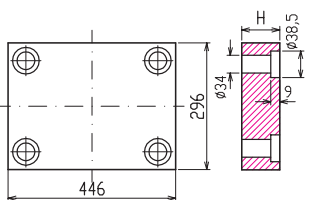
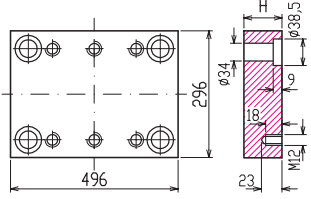
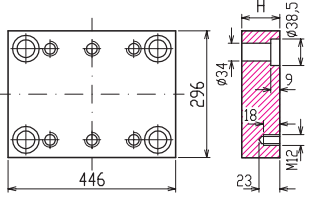

KOLONLAR / PILLARS

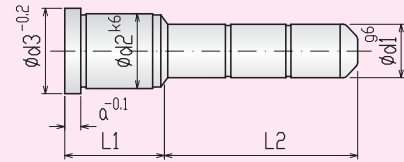

S K K				L2												
d1	d2	d3	a	L1	26	36	46	56	66	76	86	96	106	116	126	136
25	34	38	8	26	36	46	56	66	76	86	96	106	116	126	136	

BURÇLAR / GUIDE BUSHES

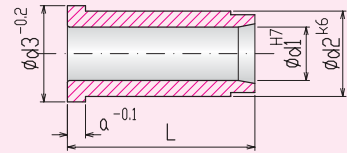

S B				L								
d1	d2	d3	a	26	36	46	56	66	76	86	96	106
25	34	38	8	26	36	46	56	66	76	86	96	106

ÇİVATALAR / SOCKET CAP SCREWS

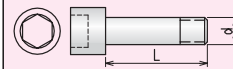

DIN 912 12.9

d	L	20	25	30	35	40	45	50	60	70	80	90	100	110	120	130	140	150	160	180	200	220	240	260	280
M8																									
M12																									

YAYLI RONDELA / SPRING WASHER

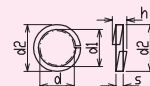

h <sub>max</sub>	d <sub>1</sub>	d <sub>2</sub>	d	s
5.9	12.2	18	12	2.5



# Enjeksiyon Kalıp Seti 346 Serisi

## 346 Series of Injection Mold Base

e  
346

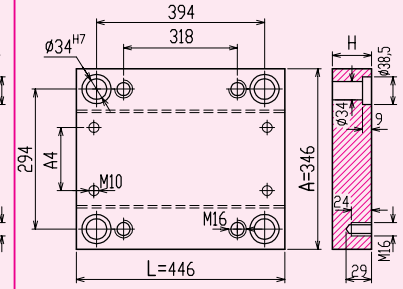
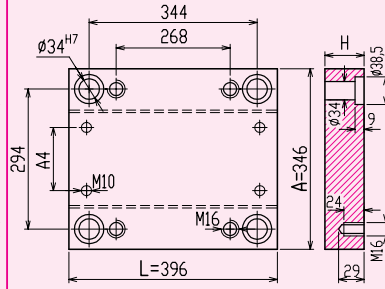
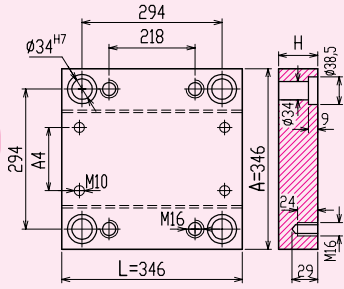

Plakalar / Plates	H	E3434	E3439	E3444									
 H1 H2	37	 346	 396	 446									
	47												
	57												
	67												
	77												
	87												
 H6	27	 346	 396	 446									
	37												
	47												
	57												
	67												
	77												
 H4	27	 346	 396	 446									
	37												
	47												
	57												
 H3	57	 346	 396	 446									
	67												
	77												
	87												
	97												
 H5 H9	37	 346	 396	 446									
	47												
 H7	17	 346	 396	 446									
	22												
	<table border="1"> <tr> <td>A5</td> <td>A3</td> <td>A4</td> </tr> <tr> <td>47</td> <td>248</td> <td>224</td> </tr> <tr> <td>57</td> <td>228</td> <td>204</td> </tr> </table>				A5	A3	A4	47	248	224	57	228	204
A5	A3	A4											
47	248	224											
57	228	204											
 H8	22	 346	 396	 446									
	<table border="1"> <tr> <td>A5</td> <td>A3</td> <td>A4</td> </tr> <tr> <td>47</td> <td>248</td> <td>224</td> </tr> <tr> <td>57</td> <td>228</td> <td>204</td> </tr> </table>				A5	A3	A4	47	248	224	57	228	204
	A5				A3	A4							
47	248	224											
57	228	204											
<table border="1"> <tr> <td>A5</td> <td>A3</td> <td>A4</td> </tr> <tr> <td>47</td> <td>248</td> <td>224</td> </tr> <tr> <td>57</td> <td>228</td> <td>204</td> </tr> </table>	A5	A3	A4	47	248	224	57	228	204				
A5	A3	A4											
47	248	224											
57	228	204											





# Enjeksiyon Kalıp Seti 346 Serisi 346 Series of Injection Mold Base

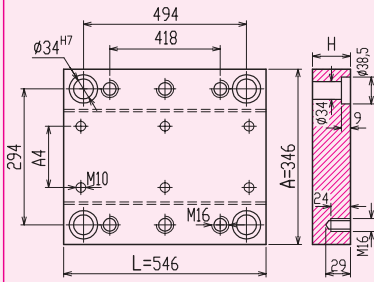
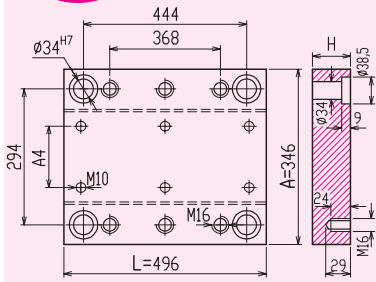

E3449

E3454

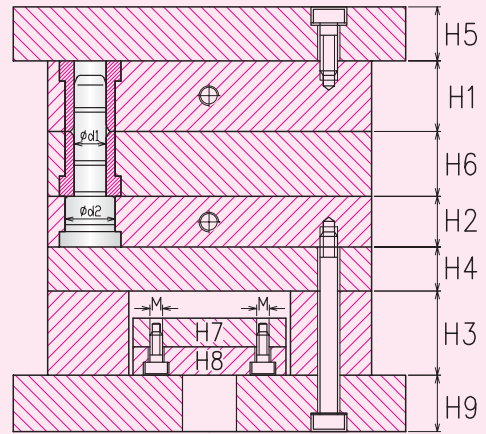
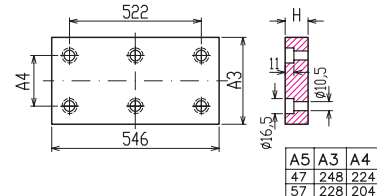
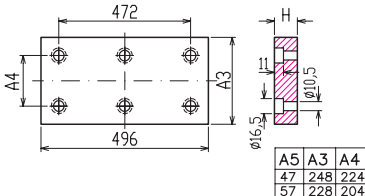
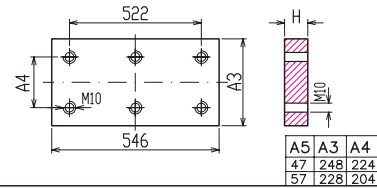
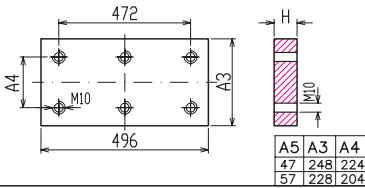
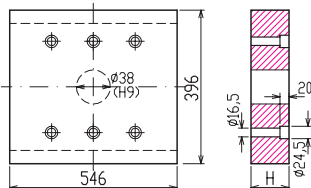
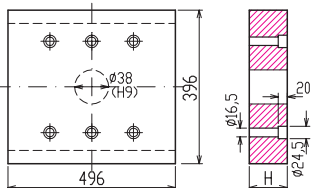
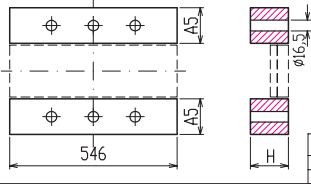
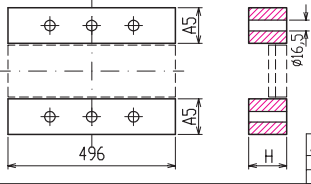
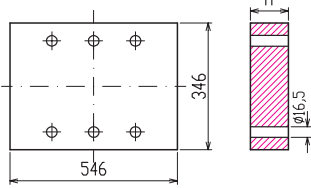
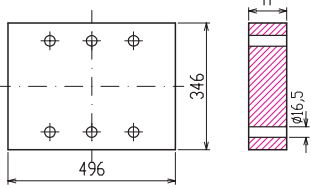
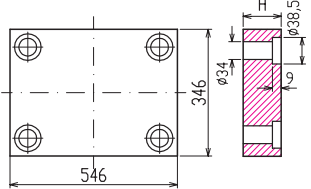
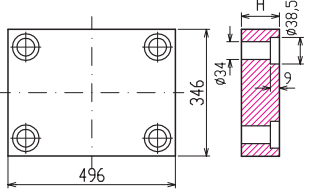
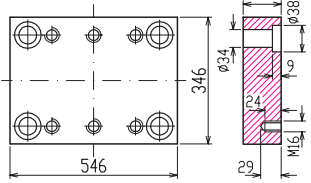
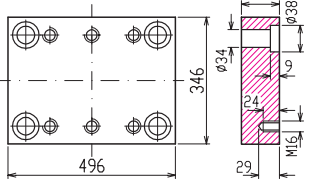

KOLONLAR / PILLARS

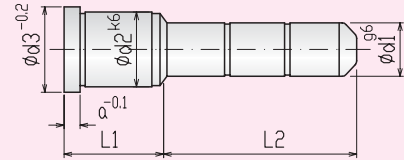

S			K			L2										
d1	d2	d3	a	L1	26	36	46	56	66	76	86	96	106	116	126	136
25	34	38	8	26	36	46	56	66	76	86	96	106	116	126	136	

BURÇLAR / GUIDE BUSHES

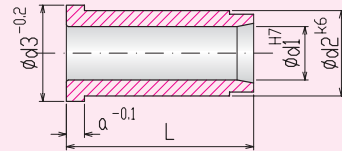

S			B			L										
d1	d2	d3	a	26	36	46	56	66	76	86	96	106				
25	34	38	8	26	36	46	56	66	76	86	96	106				

ÇİVATALAR / SOCKET CAP SCREWS

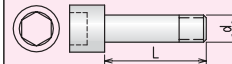

DIN 912 12.9

d	20	25	30	35	40	45	50	60	70	80	90	100	110	120	130	140	150	160	180	200	220	240	260	280	
M10																									
M16																									

YAYLI RONDELA / SPRING WASHER

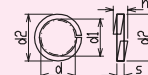

h <sub>max</sub>	d1	d2	d	s
8.3	16.2	24.4	16	3.5



# Enjeksiyon Kalıp Seti 396 Serisi

## 396 Series of Injection Mold Base

e  
396

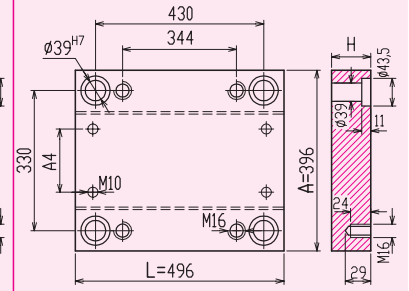
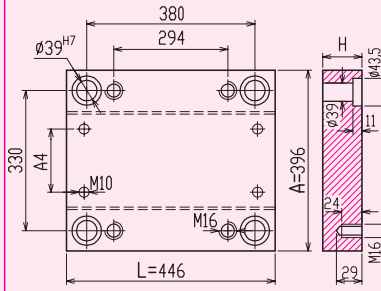
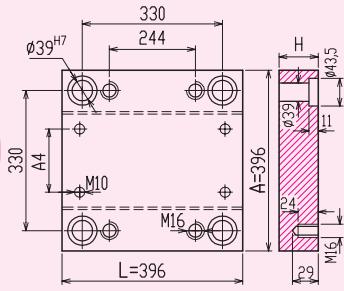

Plakalar / Plates	H	E3939	E3944	E3949
<b>H1-H2</b> 	37			
	47			
	57			
	67			
	77			
	87			
	97			
<b>H6</b> 	37			
	47			
	57			
	67			
	77			
	87			
	97			
<b>H4</b> 	27			
	37			
	47			
	57			
<b>H3</b> 	77			
	87			
	97			
	107			
	117			
<b>H5-H9</b> 	37			
	47			
	57			
<b>H7</b> 	22			
	27			
<b>H8</b> 	27			



# Enjeksiyon Kalıp Seti 396 Serisi 396 Series of Injection Mold Base

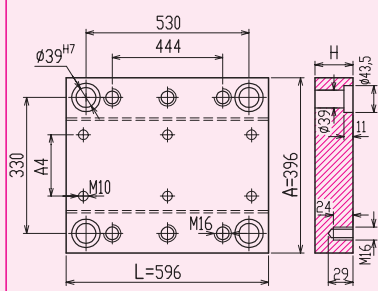
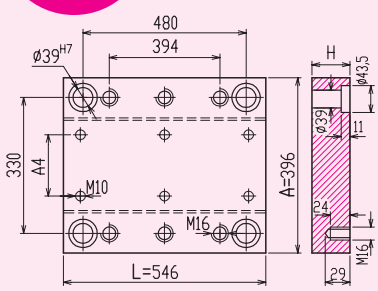

E3954

E3959

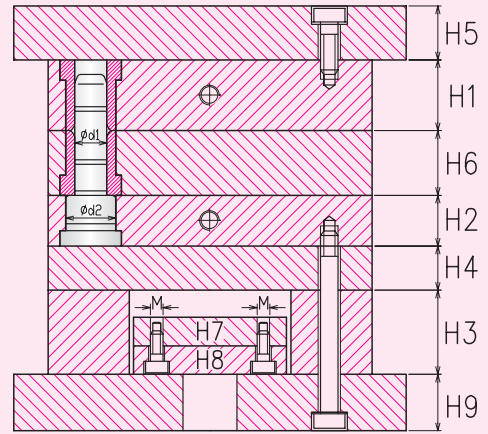
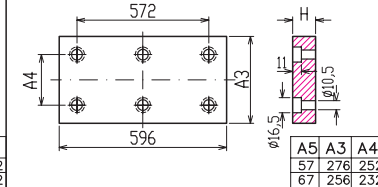
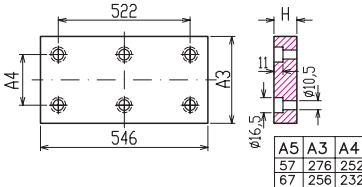
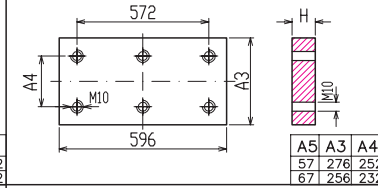
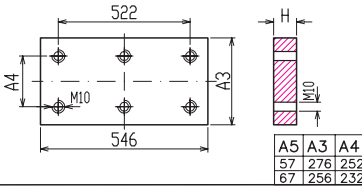
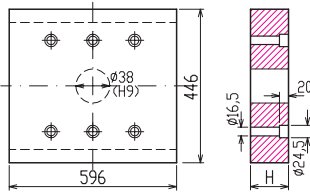
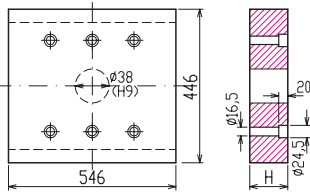
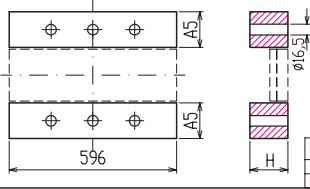
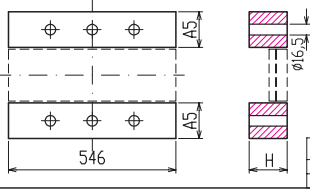
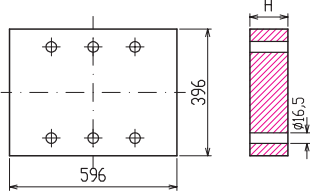
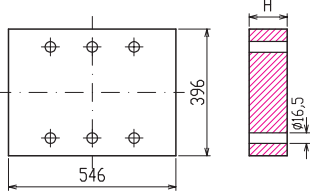
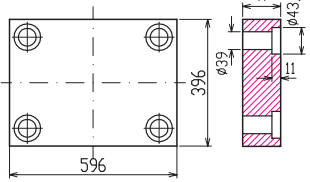
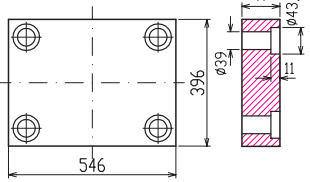
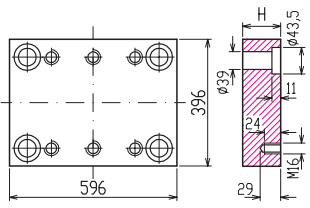
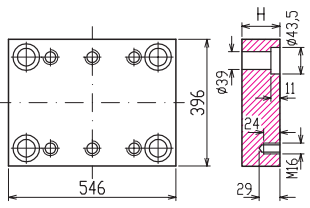

KOLONLAR / PILLARS

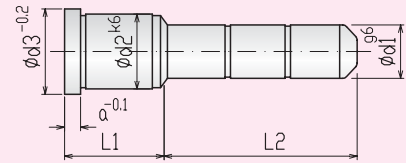

S			K													
d1	d2	d3	a	L1	36	46	56	66	76	86	96	106	116	126	136	146
30	39	43	10													

BURÇLAR / GUIDE BUSHES

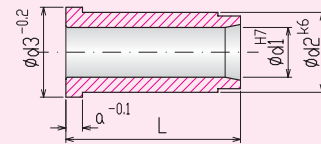

S			B										
d1	d2	d3	a	36	46	56	66	76	86	96	106	116	
30	39	43	10										

ÇİVATALAR / SOCKET CAP SCREWS

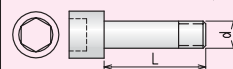

DIN 912 12.9

d	L	20	25	30	35	40	45	50	60	70	80	90	100	110	120	130	140	150	160	180	200	220	240	260	280
M10																									
M16																									

YAYLI RONDELA / SPRING WASHER

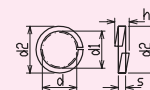

$h_{min}$	d1	d2	d	s
8.3	16.2	24.4	16	3.5



# Enjeksiyon Kalıp Seti 446 Serisi

## 446 Series of Injection Mold Base

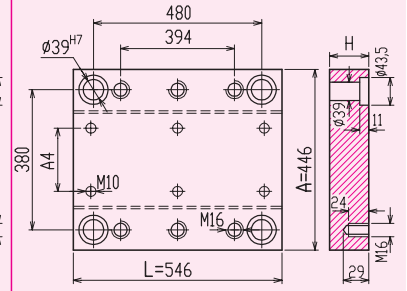
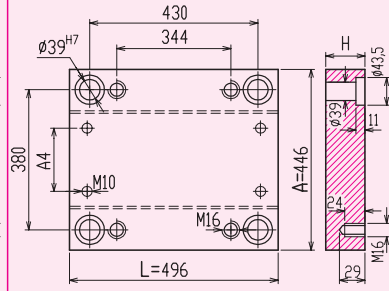
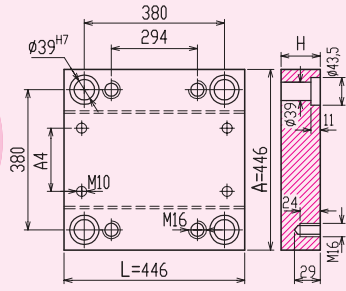

Plakalar / Plates	H	E4444	E4449	E4454									
H1-H2	37												
	47												
	57												
	67												
	77												
	87												
	97												
H6	37												
	47												
	57												
	67												
	77												
	87												
	97												
H4	37												
	47												
	57												
	67												
H3	77												
	87												
	97												
	107												
	117												
H5-H9	37												
	47												
	57												
H7	22												
	27												
	<table border="1"> <tr><td>A5</td><td>A3</td><td>A4</td></tr> <tr><td>57</td><td>326</td><td>302</td></tr> <tr><td>77</td><td>286</td><td>262</td></tr> </table>				A5	A3	A4	57	326	302	77	286	262
A5	A3	A4											
57	326	302											
77	286	262											
H8	27												
	<table border="1"> <tr><td>A5</td><td>A3</td><td>A4</td></tr> <tr><td>57</td><td>326</td><td>302</td></tr> <tr><td>77</td><td>286</td><td>262</td></tr> </table>				A5	A3	A4	57	326	302	77	286	262
	A5				A3	A4							
57	326	302											
77	286	262											
<table border="1"> <tr><td>A5</td><td>A3</td><td>A4</td></tr> <tr><td>57</td><td>326</td><td>302</td></tr> <tr><td>77</td><td>286</td><td>262</td></tr> </table>	A5	A3	A4	57	326	302	77	286	262				
A5	A3	A4											
57	326	302											
77	286	262											



# Enjeksiyon Kalıp Seti 446 Serisi 446 Series of Injection Mold Base

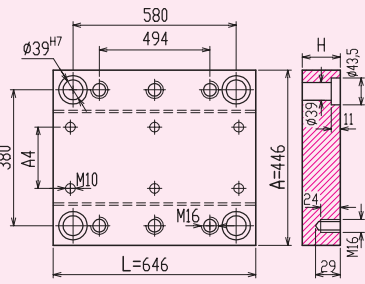
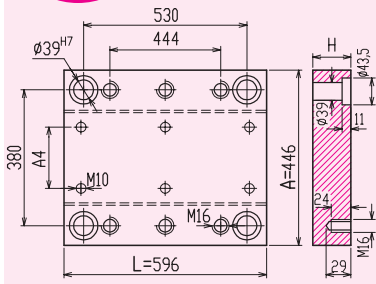

**E4459**

**E4464**

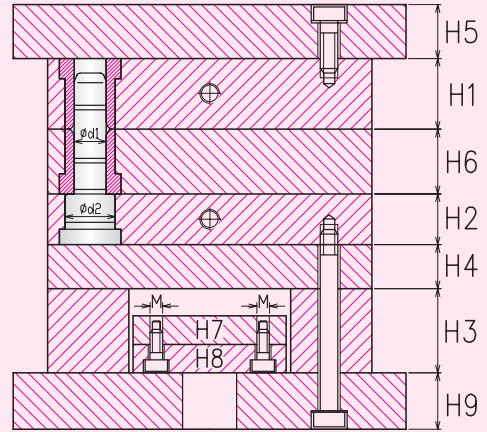
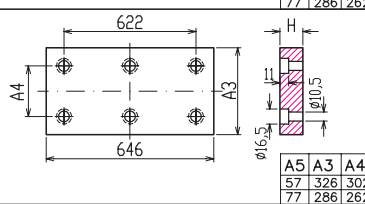
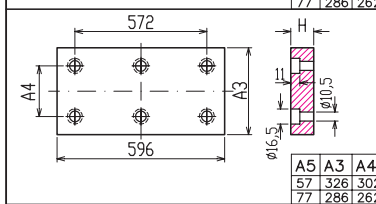
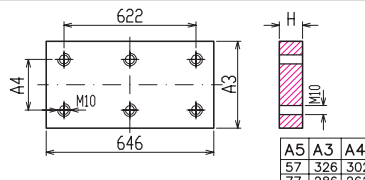
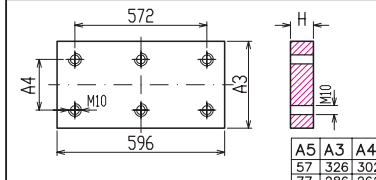
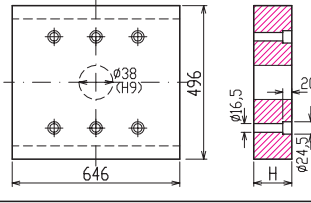
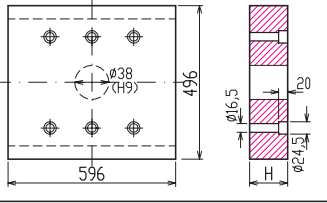
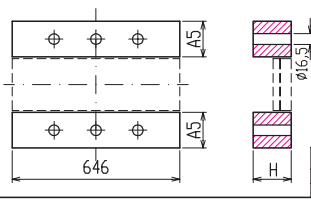
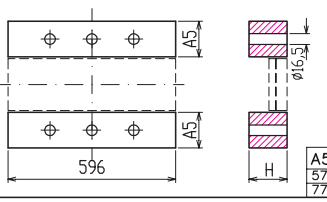
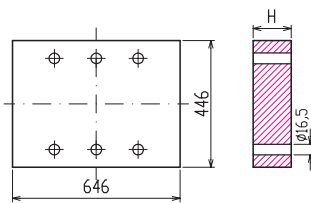
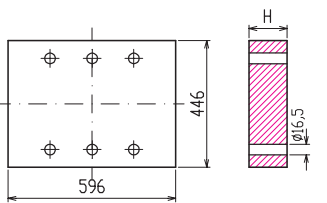
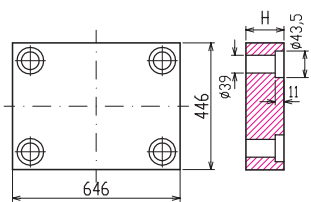
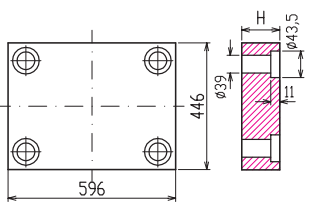
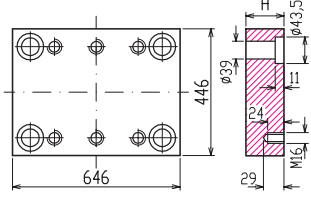
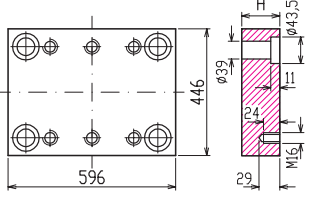

**KOLONLAR / PILLARS**

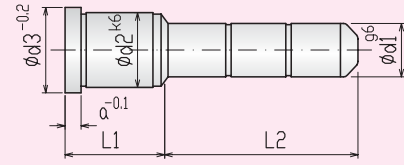

S			K			L2										
d1	d2	d3	a	L1	36	46	56	66	76	86	96	106	116	126	136	146
30	39	43	10	36	46	56	66	76	86	96	106	116				
				46												
				56												
				66												
				76												
				86												
				96												
				106												
				116												

**BURÇLAR / GUIDE BUSHES**

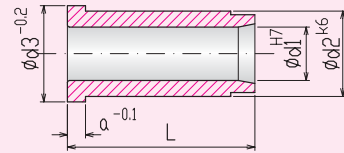

S			B			L						
d1	d2	d3	a	36	46	56	66	76	86	96	106	116
30	39	43	10	36	46	56	66	76	86	96	106	116

**ÇİVATALAR / SOCKET CAP SCREWS**

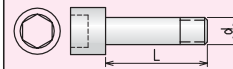

DIN 912 12.9

d	L	20	25	30	35	40	45	50	60	70	80	90	100	110	120	130	140	150	160	180	200	220	240	260	280	
M10																										
M16																										

**YAYLI RONDELA / SPRING WASHER**

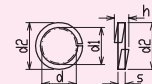

h <sub>max</sub>	d <sub>1</sub>	d <sub>2</sub>	d	s
8.3	16.2	24.4	16	3.5



# Enjeksiyon Kalıp Seti 496 Serisi

## 496 Series of Injection Mold Base

e  
496

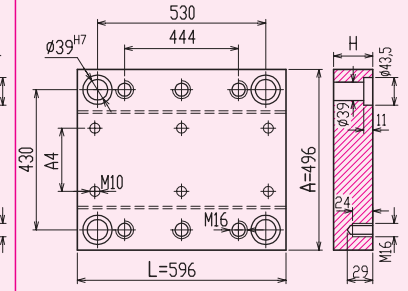
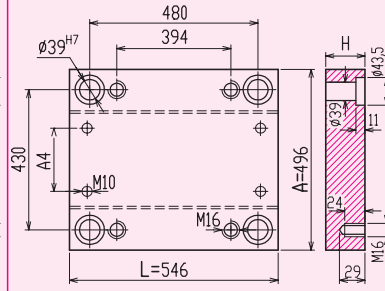
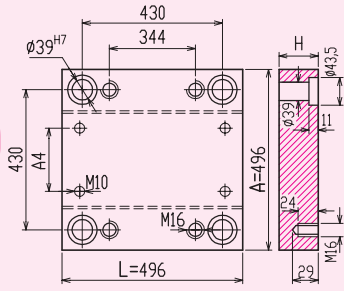

Plakalar / Plates	H	E4949	E4954	E4959									
<b>H1-H2</b> 	37												
	47												
	57												
	67												
	77												
	87												
	97												
<b>H6</b> 	37												
	47												
	57												
	67												
	77												
	87												
	97												
<b>H4</b> 	37												
	47												
	57												
	67												
	77												
<b>H3</b> 	77												
	87												
	97												
	107												
	117												
<b>H5-H9</b> 	37												
	47												
	57												
<b>H7</b> 	22												
	27												
	<table border="1"> <tr><td>A5</td><td>A3</td><td>A4</td></tr> <tr><td>57</td><td>376</td><td>352</td></tr> <tr><td>77</td><td>336</td><td>312</td></tr> </table>				A5	A3	A4	57	376	352	77	336	312
A5	A3	A4											
57	376	352											
77	336	312											
<b>H8</b> 	27												
	<table border="1"> <tr><td>A5</td><td>A3</td><td>A4</td></tr> <tr><td>57</td><td>376</td><td>352</td></tr> <tr><td>77</td><td>336</td><td>312</td></tr> </table>				A5	A3	A4	57	376	352	77	336	312
	A5				A3	A4							
57	376	352											
77	336	312											
<table border="1"> <tr><td>A5</td><td>A3</td><td>A4</td></tr> <tr><td>57</td><td>376</td><td>352</td></tr> <tr><td>77</td><td>336</td><td>312</td></tr> </table>	A5	A3	A4	57	376	352	77	336	312				
A5	A3	A4											
57	376	352											
77	336	312											



# Enjeksiyon Kalıp Seti 496 Serisi

## 496 Series of Injection Mold Base

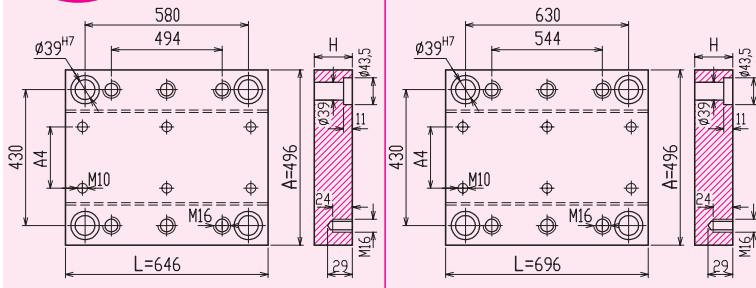

E4964

E4969

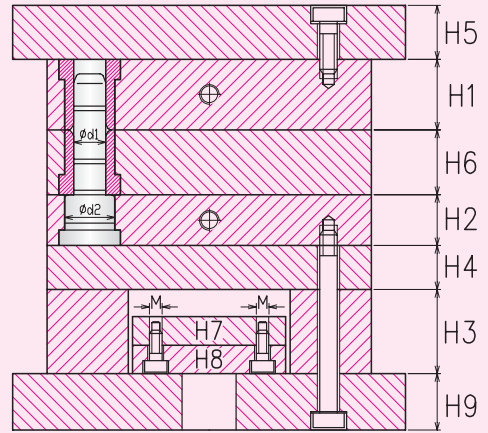
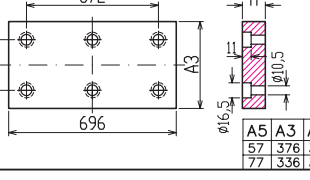
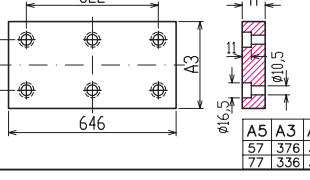
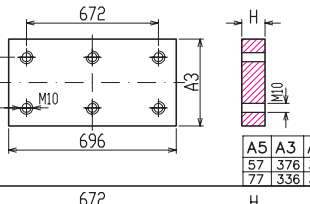
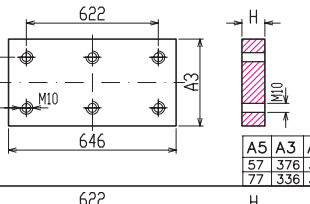
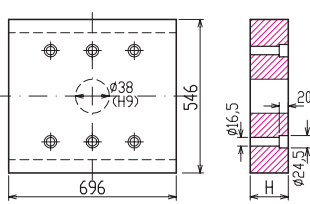
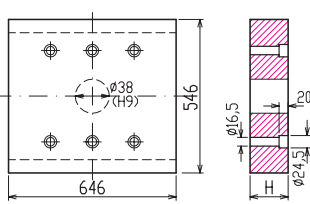
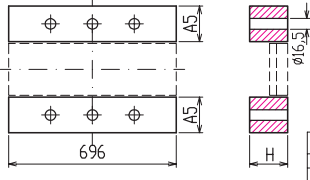
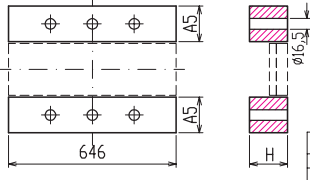
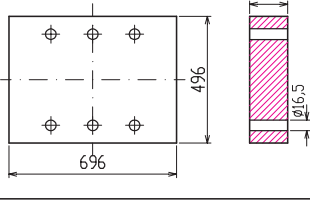
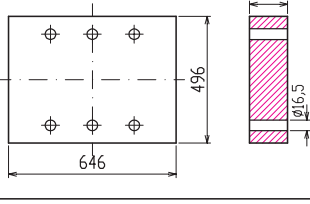
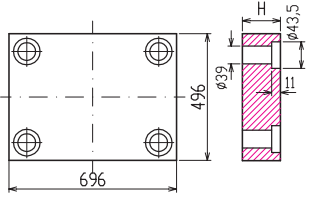
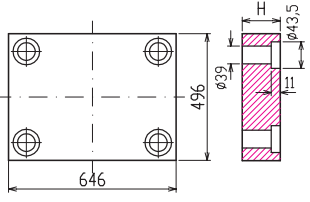
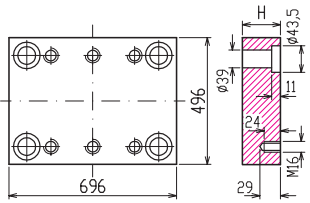
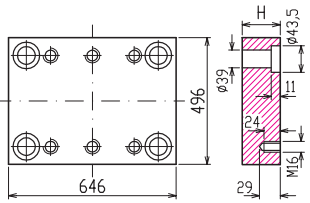

KOLONLAR / PILLARS

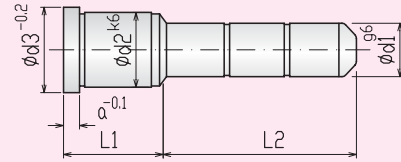

S K K			L2													
d1	d2	d3	a	L1	36	46	56	66	76	86	96	106	116	126	136	146
30	39	43	10	36	46	56	66	76	86	96	106	116				

BURÇLAR / GUIDE BUSHES

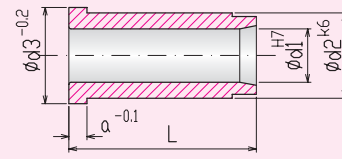

S B			L													
d1	d2	d3	a	36	46	56	66	76	86	96	106	116				
30	39	43	10	36	46	56	66	76	86	96	106	116				

CIVATALAR / SOCKET CAP SCREWS



DIN 912 12.9

d	L	20	25	30	35	40	45	50	60	70	80	90	100	110	120	130	140	150	160	180	200	220	240	260	280
M10																									
M16																									

YAYLI RONDELA / SPRING WASHER



d	d <sub>max</sub>	d <sub>1</sub>	d <sub>2</sub>	d	s
8	8.3	16	2	4	16
10	10.5	20	2.5	5	20



# Enjeksiyon Kalıp Seti 546 Serisi

## 546 Series Injection Mold Base

e  
546

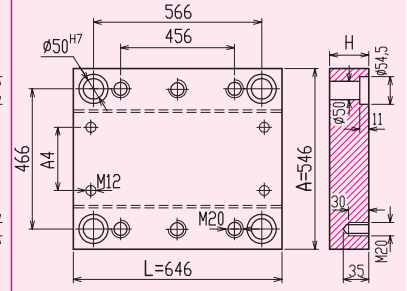
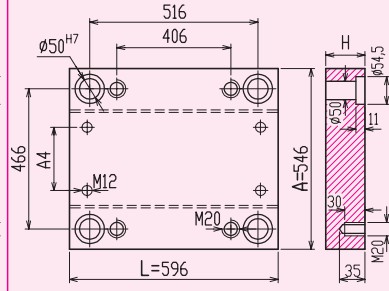
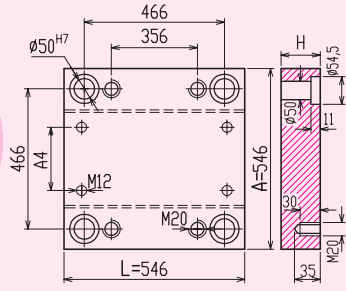

Plakalar / Plates	H	E5454	E5459	E5464																													
<b>H1-H2</b> 	47																																
	57																																
	67																																
	77																																
	87																																
	97																																
	107																																
	117																																
<b>H6</b> 	47																																
	57																																
	67																																
	77																																
	87																																
	97																																
	107																																
	117																																
<b>H4</b> 	47																																
	57																																
	67																																
	77																																
<b>H3</b> 	77																																
	87																																
	97																																
	107																																
	117																																
	127																																
<b>H5-H9</b> 	47																																
	57																																
	67																																
<b>H7</b> 	22																																
	27																																
	<table border="1"> <tr><td>A5</td><td>A3</td><td>A4</td></tr> <tr><td>68</td><td>405</td><td>375</td></tr> <tr><td>87</td><td>365</td><td>335</td></tr> </table>				A5	A3	A4	68	405	375	87	365	335	<table border="1"> <tr><td>A5</td><td>A3</td><td>A4</td></tr> <tr><td>68</td><td>405</td><td>375</td></tr> <tr><td>87</td><td>365</td><td>335</td></tr> </table>	A5	A3	A4	68	405	375	87	365	335	<table border="1"> <tr><td>A5</td><td>A3</td><td>A4</td></tr> <tr><td>68</td><td>405</td><td>375</td></tr> <tr><td>87</td><td>365</td><td>335</td></tr> </table>	A5	A3	A4	68	405	375	87	365	335
	A5				A3	A4																											
	68				405	375																											
87	365	335																															
A5	A3	A4																															
68	405	375																															
87	365	335																															
A5	A3	A4																															
68	405	375																															
87	365	335																															
<b>H8</b> 	27																																
	37																																
	<table border="1"> <tr><td>A5</td><td>A3</td><td>A4</td></tr> <tr><td>68</td><td>405</td><td>375</td></tr> <tr><td>87</td><td>365</td><td>335</td></tr> </table>				A5	A3	A4	68	405	375	87	365	335	<table border="1"> <tr><td>A5</td><td>A3</td><td>A4</td></tr> <tr><td>68</td><td>405</td><td>375</td></tr> <tr><td>87</td><td>365</td><td>335</td></tr> </table>	A5	A3	A4	68	405	375	87	365	335	<table border="1"> <tr><td>A5</td><td>A3</td><td>A4</td></tr> <tr><td>68</td><td>405</td><td>375</td></tr> <tr><td>87</td><td>365</td><td>335</td></tr> </table>	A5	A3	A4	68	405	375	87	365	335
	A5				A3	A4																											
	68				405	375																											
87	365	335																															
A5	A3	A4																															
68	405	375																															
87	365	335																															
A5	A3	A4																															
68	405	375																															
87	365	335																															





# Enjeksiyon Kalıp Seti 546 Serisi

## 546 Series Injection Mold Base

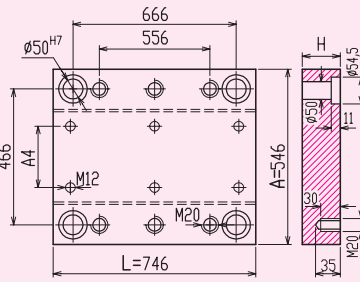
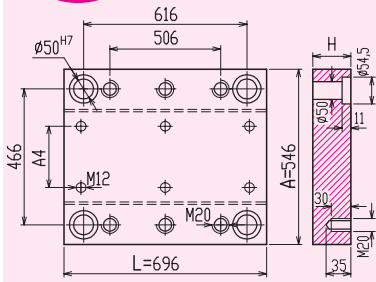

E5469

E5474

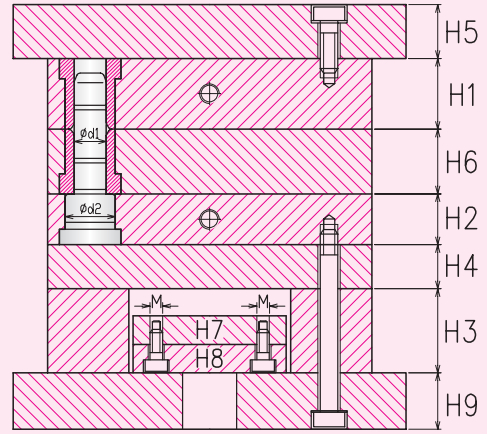
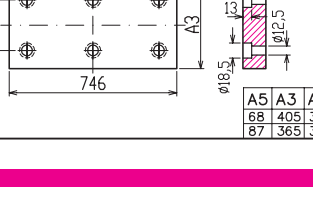
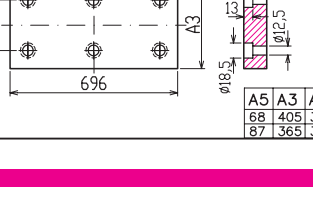
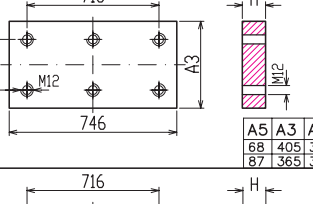
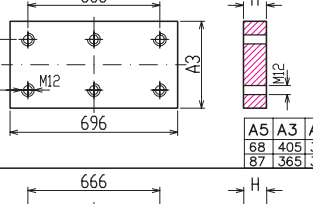
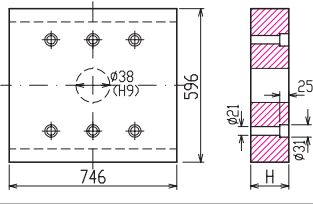
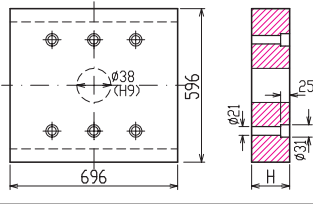
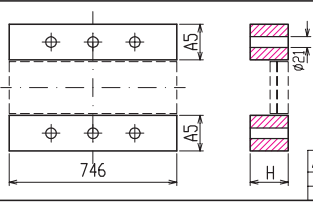
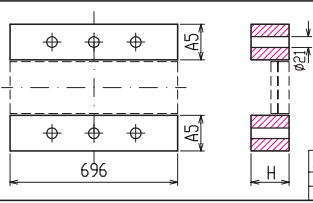
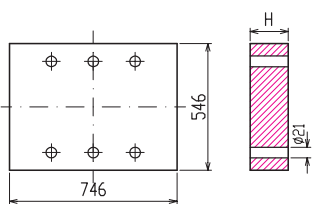
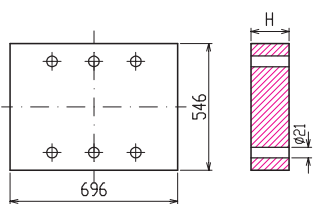
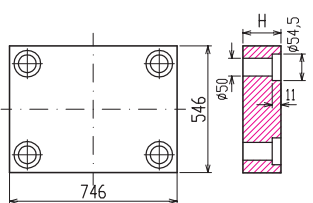
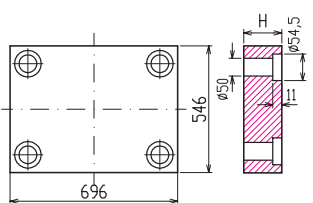
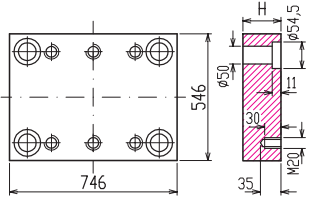
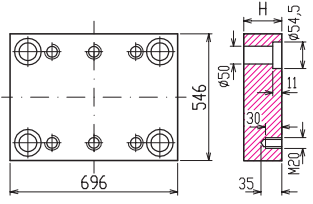

### KOLONLAR / PILLARS

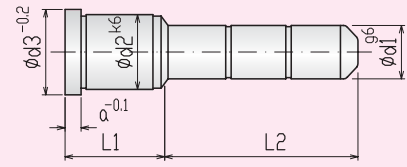

S			K			L2										
d1	d2	d3	a	L1	46	56	66	76	86	96	106	116	126	136	146	156
40	50	54	10	46	56	66	76	86	96	106	116	126	STOKLARDA MEVCUT DEĞİLDİR ÖZEL OLARAK İMAL EDİLİR (NOT IN STOCK CUSTOM BUILD)			

### BURÇLAR / GUIDE BUSHES

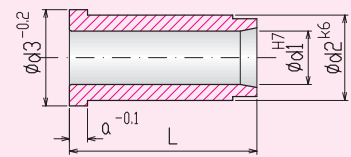

S			B			L										
d1	d2	d3	a	46	56	66	76	86	96	106	116	126				
40	50	54	10	ÖZEL OLARAK İMAL EDİLİR (CUSTOM BUILD)												

### ÇİVATALAR / SOCKET CAP SCREWS

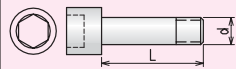

d	25	30	35	40	45	50	60	70	80	90	100	110	120	130	140	150	160	180	200	220	240	260	280	300	
M12																									
M20																									

### YAYLI RONDELA / SPRING WASHER

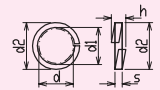

h <sub>max</sub>	d <sub>1</sub>	d <sub>2</sub>	d	s
10.6	20.2	30.6	20	4.5



# Enjeksiyon Kalıp Seti 596 Serisi

## 596 Series of Injection Mold Base

e  
596

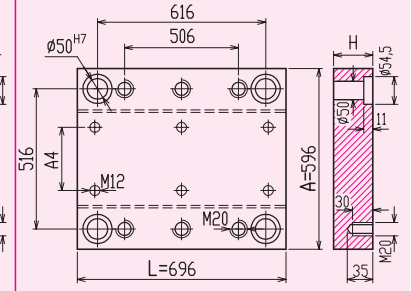
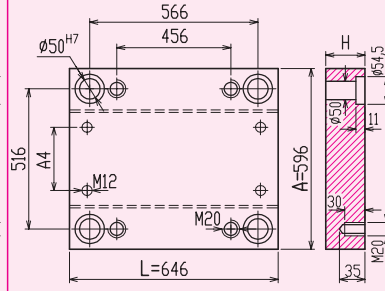
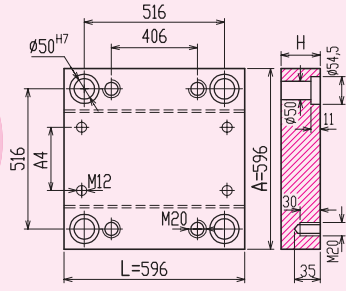

Plakalar / Plates	H	E5959	E5964	E5969			
<b>H1-H2</b> 	47						
	57						
	67						
	77						
	87						
	97						
	107						
	117						
<b>H6</b> 	47						
	57						
	67						
	77						
	87						
	97						
	107						
	117						
<b>H4</b> 	47						
	57						
	67						
	77						
<b>H3</b> 	77						
	87						
	97						
	107						
	117						
	127						
<b>H5-H9</b> 	47						
	57						
	67						
<b>H7</b> 	22						
	27						
	A5 A3 A4 68 455 425 87 415 385						
	A5 A3 A4 68 455 425 87 415 385						
<b>H8</b> 	27						
	37						
	A5 A3 A4 68 455 425 87 415 385						
	A5 A3 A4 68 455 425 87 415 385						



# Enjeksiyon Kalıp Seti 596 Serisi

## 596 Series of Injection Mold Base

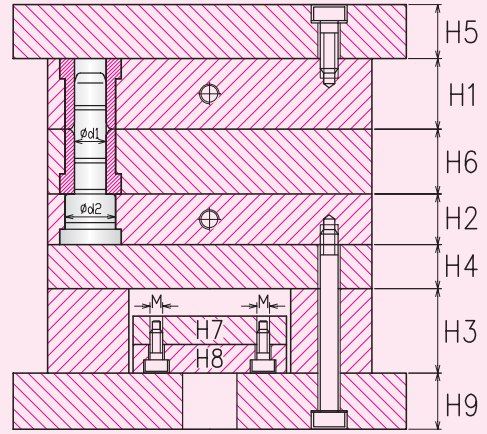
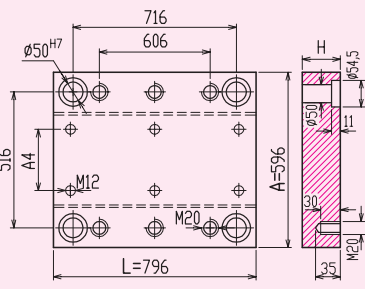
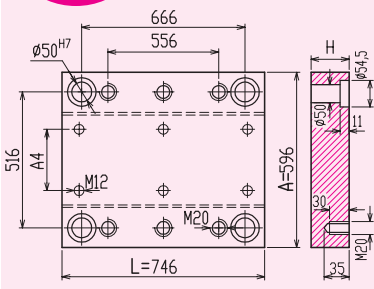

E5974

E5979

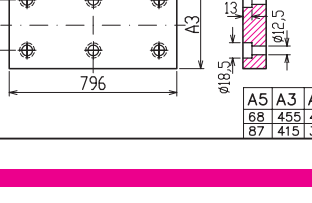
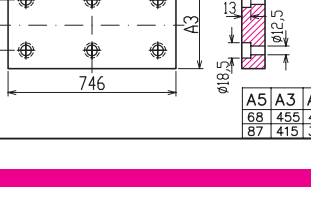
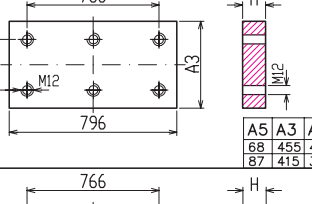
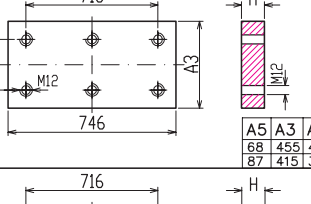
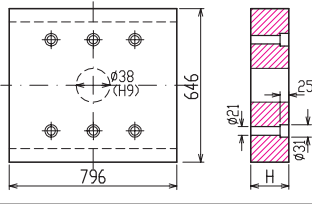
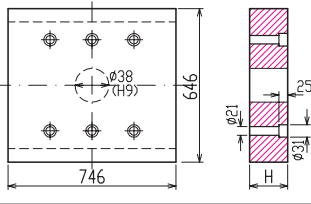
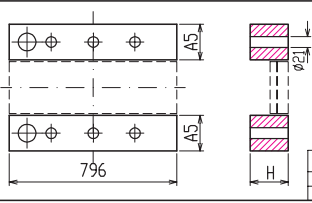
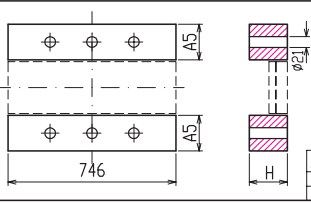
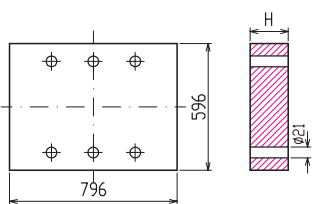
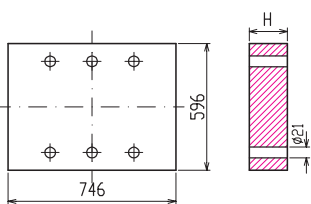
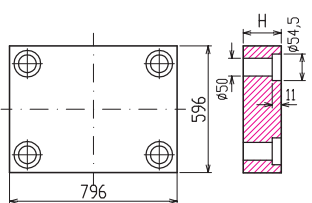
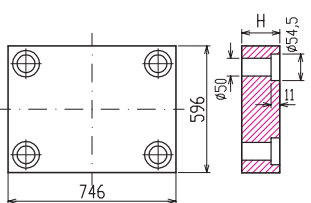
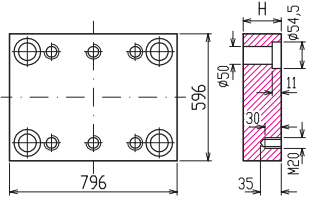
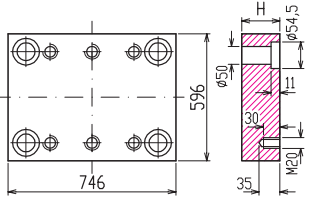

### KOLONLAR / PILLARS

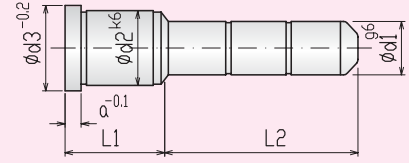

S	K	K	L2													
d1	d2	d3	a	L1	46	56	66	76	86	96	106	116	126	136	146	156
40	50	54	10	46	56	66	76	86	96	106	116	126	136	146	156	

STOKLARDA MEVCUT DEĞİLDİR  
ÖZEL OLARAK İMAL EDİLİR  
(NOT IN STOCK CUSTOM BUILD)

### BURÇLAR / GUIDE BUSHES

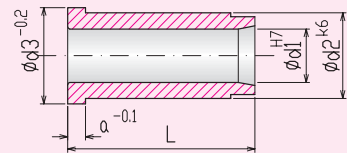

S	B	L												
d1	d2	d3	a	46	56	66	76	86	96	106	116	126		
40	50	54	10	46	56	66	76	86	96	106	116	126		

ÖZEL OLARAK İMAL EDİLİR  
(CUSTOM BUILD)

### ÇİVATALAR / SOCKET CAP SCREWS

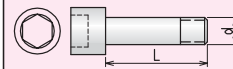

DIN 912 12.9

d	L	25	30	35	40	45	50	60	70	80	90	100	110	120	130	140	150	160	180	200	220	240	260	280	300	
M12																										
M20																										

### YAYLI RONDELA / SPRING WASHER

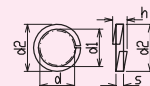

h <sub>max</sub>	d <sub>1</sub>	d <sub>2</sub>	d	s
10.6	20.2	30.6	20	4.5



# Enjeksiyon Kalıp Seti 646 Serisi

## 646 Series of Injection Mold Base

e  
646

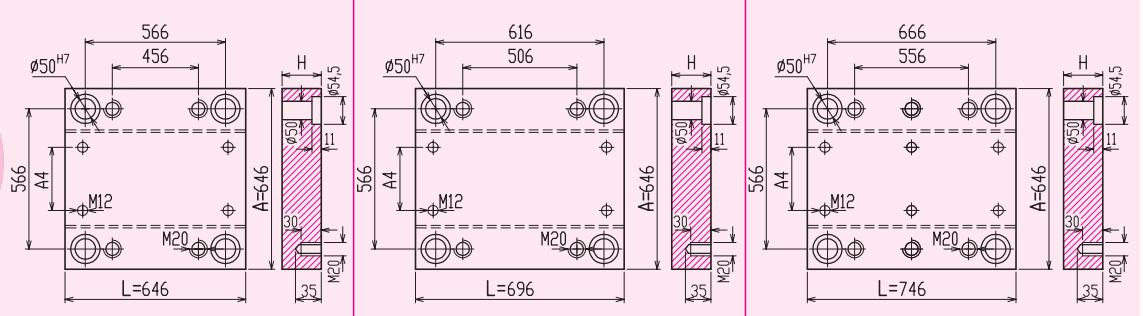

Plakalar / Plates	H	E6464	E6469	E6474																													
<b>H1-H2</b> 	47																																
	57																																
	67																																
	77																																
	87																																
	97																																
	107																																
	117																																
<b>H6</b> 	47																																
	57																																
	67																																
	77																																
	87																																
	97																																
	107																																
	117																																
<b>H4</b> 	47																																
	57																																
	67																																
	77																																
<b>H3</b> 	77																																
	87																																
	97																																
	107																																
	117																																
	127																																
<b>H5-H9</b> 	47																																
	57																																
	67																																
<b>H7</b> 	22																																
	27																																
	<table border="1"> <tr><td>A5</td><td>A3</td><td>A4</td></tr> <tr><td>68</td><td>505</td><td>475</td></tr> <tr><td>87</td><td>465</td><td>435</td></tr> </table>				A5	A3	A4	68	505	475	87	465	435	<table border="1"> <tr><td>A5</td><td>A3</td><td>A4</td></tr> <tr><td>68</td><td>505</td><td>475</td></tr> <tr><td>87</td><td>465</td><td>435</td></tr> </table>	A5	A3	A4	68	505	475	87	465	435	<table border="1"> <tr><td>A5</td><td>A3</td><td>A4</td></tr> <tr><td>68</td><td>505</td><td>475</td></tr> <tr><td>87</td><td>465</td><td>435</td></tr> </table>	A5	A3	A4	68	505	475	87	465	435
	A5				A3	A4																											
68	505	475																															
87	465	435																															
A5	A3	A4																															
68	505	475																															
87	465	435																															
A5	A3	A4																															
68	505	475																															
87	465	435																															
37																																	
<b>H8</b> 	27																																
	37																																
	<table border="1"> <tr><td>A5</td><td>A3</td><td>A4</td></tr> <tr><td>68</td><td>505</td><td>475</td></tr> <tr><td>87</td><td>465</td><td>435</td></tr> </table>				A5	A3	A4	68	505	475	87	465	435	<table border="1"> <tr><td>A5</td><td>A3</td><td>A4</td></tr> <tr><td>68</td><td>505</td><td>475</td></tr> <tr><td>87</td><td>465</td><td>435</td></tr> </table>	A5	A3	A4	68	505	475	87	465	435	<table border="1"> <tr><td>A5</td><td>A3</td><td>A4</td></tr> <tr><td>68</td><td>505</td><td>475</td></tr> <tr><td>87</td><td>465</td><td>435</td></tr> </table>	A5	A3	A4	68	505	475	87	465	435
	A5				A3	A4																											
68	505	475																															
87	465	435																															
A5	A3	A4																															
68	505	475																															
87	465	435																															
A5	A3	A4																															
68	505	475																															
87	465	435																															
47																																	



# Enjeksiyon Kalıp Seti 646 Serisi 646 Series of Injection Mold Base

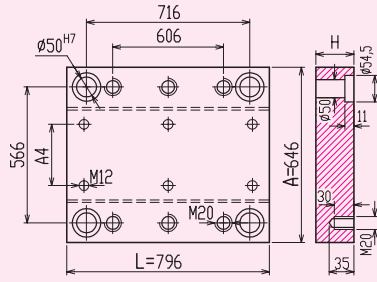

E6479

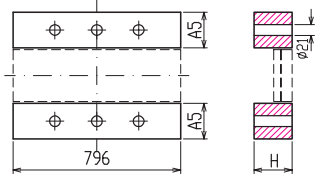
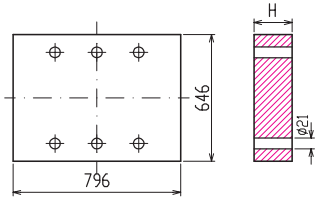
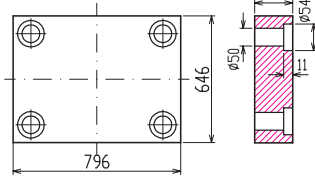
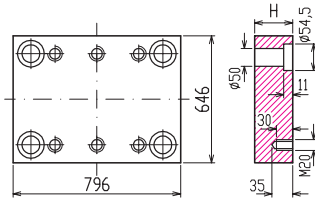

A5  
68  
87

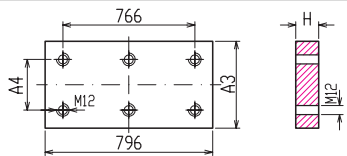
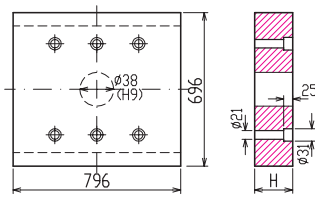

A5 A3 A4  
68 505 475  
87 465 435

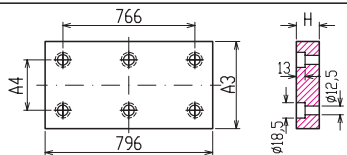

A5 A3 A4  
68 505 475  
87 465 435

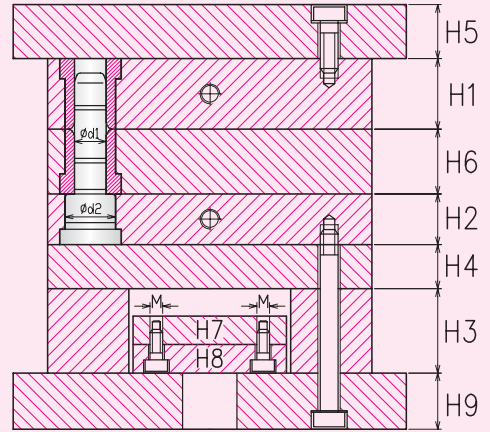

## KOLONLAR / PILLARS

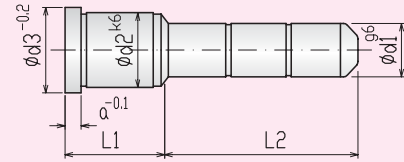

S K K			L2													
d1	d2	d3	a	L1	46	56	66	76	86	96	106	116	126	136	146	156
40	50	54	10	46	56	66	76	86	96	106	116	126	136	146	156	
STOKLARDA MEVCUT DEĞİLDİR ÖZEL OLARAK İMAL EDİLİR (NOT IN STOCK CUSTOM BUILD)																

## BURÇLAR / GUIDE BUSHES

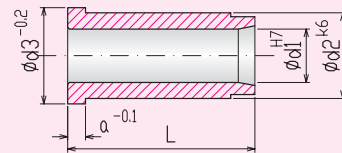

S B			L													
d1	d2	d3	a	46	56	66	76	86	96	106	116	126				
40	50	54	10	ÖZEL OLARAK İMAL EDİLİR (CUSTOM BUILD)												

## ÇİVATALAR / SOCKET CAP SCREWS

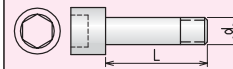

DIN 912 10.9

d	L	25	30	35	40	45	50	60	70	80	90	100	110	120	130	140	150	160	180	200	220	240	260	280	300	
M12																										
M20																										

## YAYLI RONDELA / SPRING WASHER

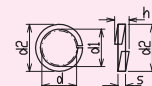

h <sub>max</sub>	d <sub>1</sub>	d <sub>2</sub>	d	s
10.6	20.2	30.6	20	4.5



# Enjeksiyon Kalıp Seti 696 Serisi

## 696 Series of Injection Mold Base

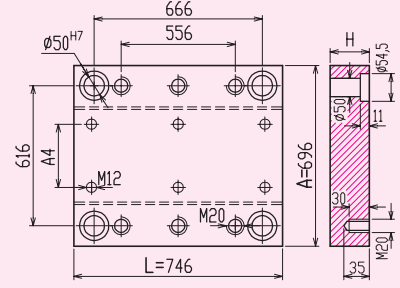
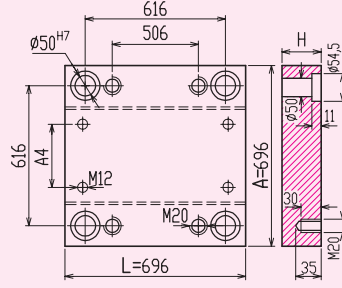

Plakalar / Plates	H	E6969	E6974
<b>H1-H2</b> 	47		
	57		
	67		
	77		
	87		
	97		
	107		
	117		
<b>H6</b> 	47		
	57		
	67		
	77		
	87		
	97		
<b>H4</b> 	47		
	57		
	67		
	77		
<b>H3</b> 	77		
	87		
	97		
	107		
	117		
	127		
<b>H5-H9</b> 	47		
	57		
	67		
<b>H7</b> 	22		
	27		
<b>H8</b> 	27		
	37		



# Enjeksiyon Kalıp Seti 696 Serisi 696 Series of Injection Mold Base

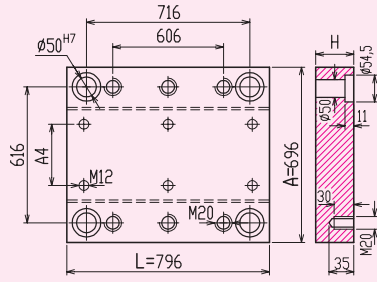

E6979

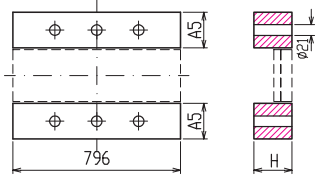
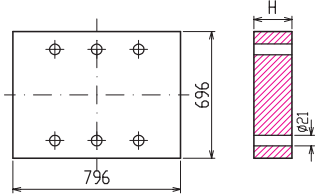
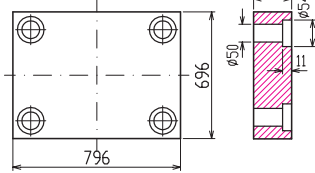
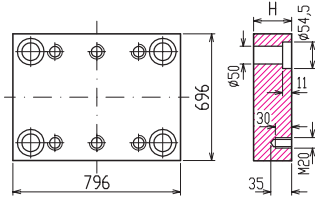

A5  
68  
87

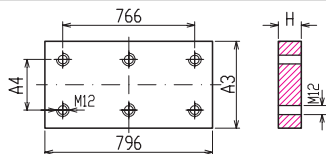
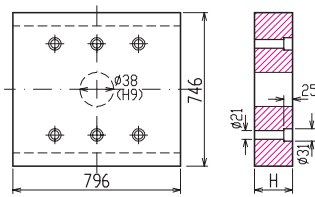

A5 A3 A4  
68 555 525  
87 515 485

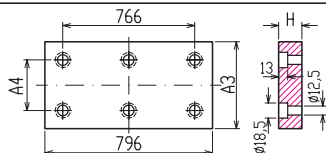

A5 A3 A4  
68 555 525  
87 515 485

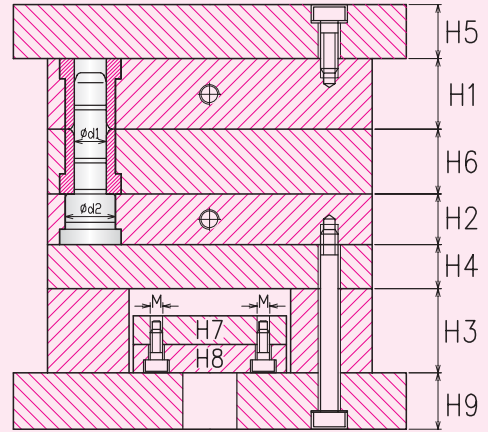

## KOLONLAR / PILLARS

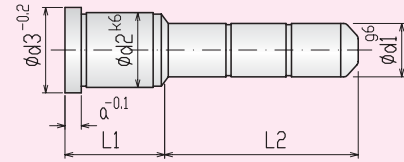

S K K			L2													
d1	d2	d3	a	L1	46	56	66	76	86	96	106	116	126	136	146	156
40	50	54	10	46	56	66	76	86	96	106	116	126	136	146	156	

STOKLARDA MEVCUT DEĞİLDİR  
ÖZEL OLARAK İMAL EDİLİR  
(NOT IN STOCK CUSTOM BUILD)

## BURÇLAR / GUIDE BUSHES

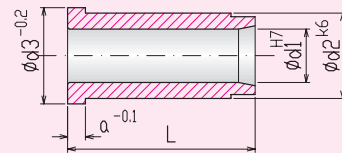

S B			L													
d1	d2	d3	a	46	56	66	76	86	96	106	116	126				
40	50	54	10	ÖZEL OLARAK İMAL EDİLİR (CUSTOM BUILD)												

## ÇİVATALAR / SOCKET CAP SCREWS

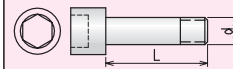

DIN 912 12.9

d	L	25	30	35	40	45	50	60	70	80	90	100	110	120	130	140	150	160	180	200	220	240	260	280	300	
M12																										
M20																										

## YAYLI RONDELA / SPRING WASHER

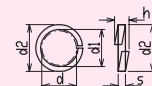

h <sub>max</sub>	d1	d2	d	s
10.6	20.2	30.6	20	4.5

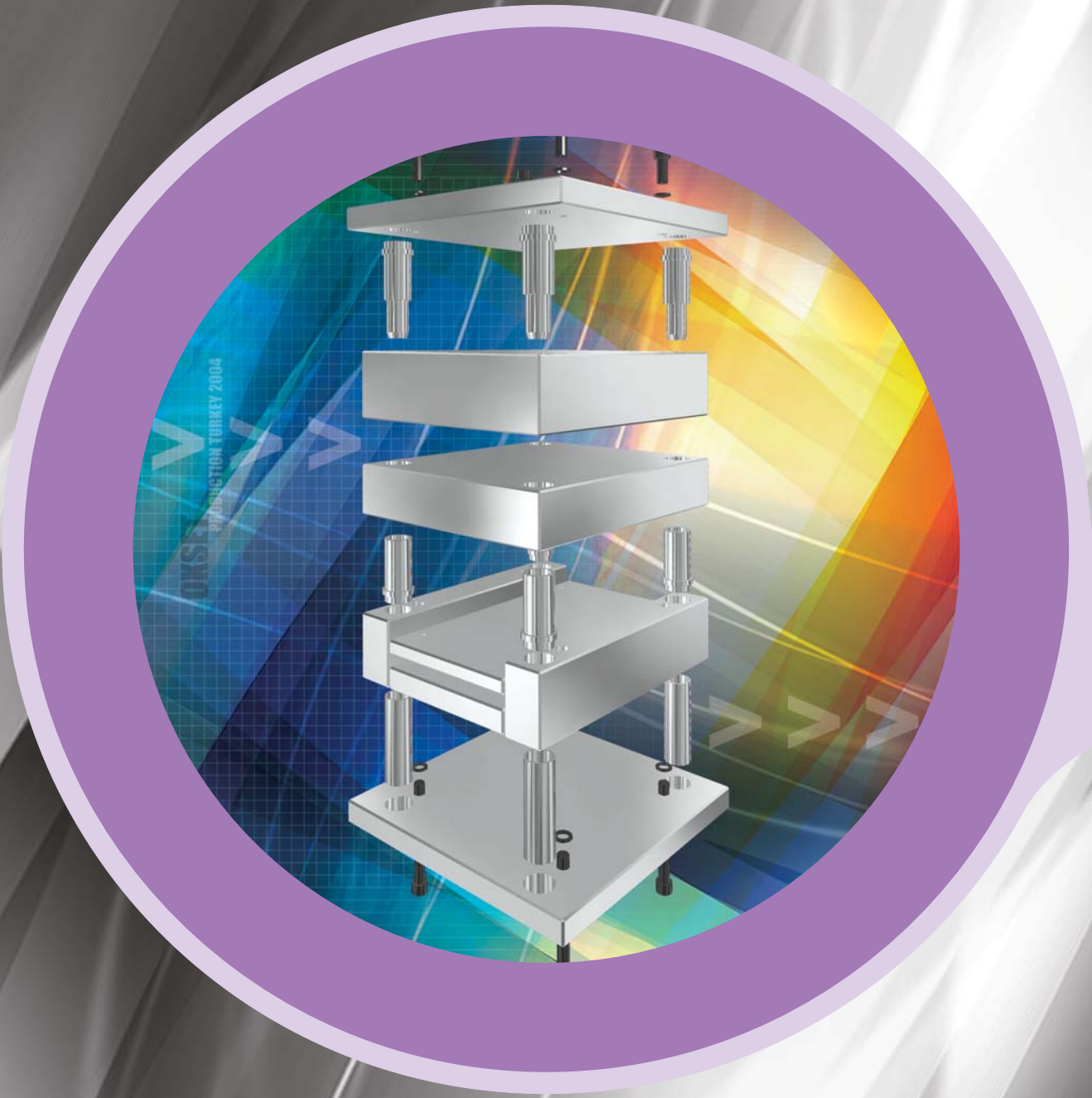

UKS  
CONSTRUCTION TURKEY 2004



# Enjeksiyon Kalıp Seti Kuyruklu Injection Mold Base with Locating Pillar

EKS EK Serisi

ek

serisi / series



 **OKSET®**



# Enjeksiyon Kalıp Seti Kuyruklu 156 Serisi

## Injection Mold Base 156 Series with Locating Pillar

ek  
156

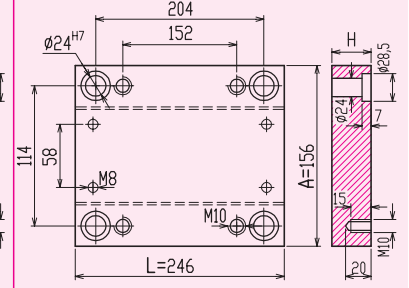
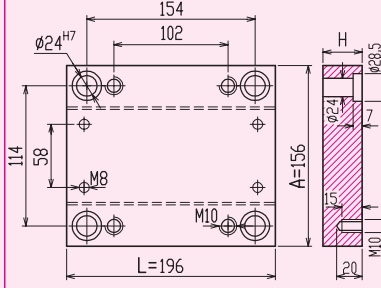
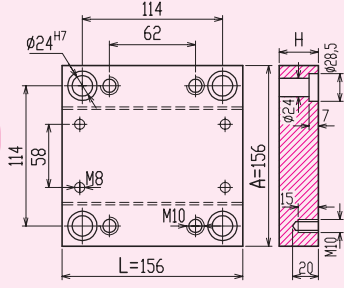

Plakalar / Plates	H	EK1515	EK1519	EK1524
H1-H2 	27			
	37			
	47			
	57			
	67			
	77			
H6 	27			
	37			
	47			
	57			
	67			
	77			
H4 	27			
	37			
	47			
H3 	57			
	67			
	77			
H5-H9 	27			
	27			
H7 	14			
	17			
H8 	17			
	17			



# Enjeksiyon Kalıp Seti Kuyruklu 156 Serisi Injection Mold Base 156 Series with Locating Pillar

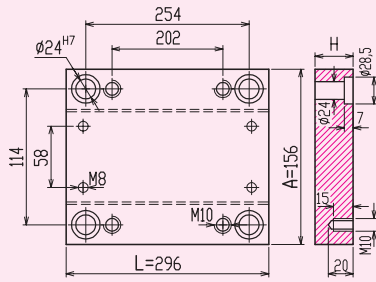

**EK1529**

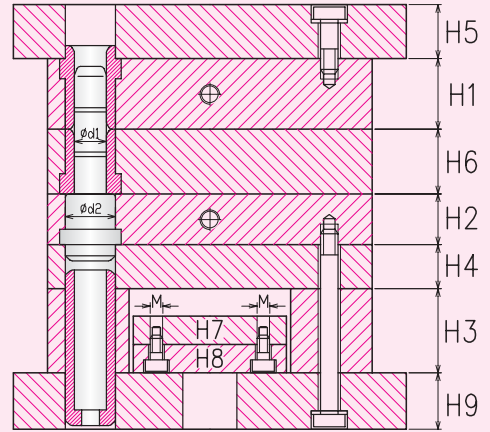
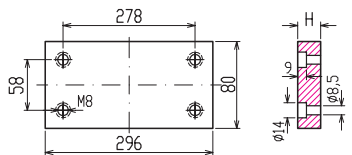
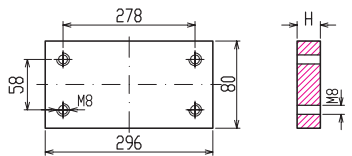
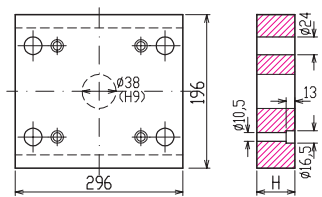
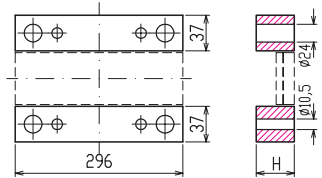
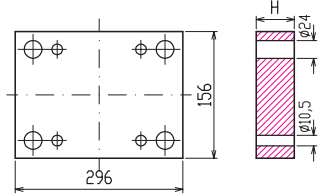
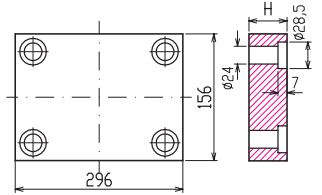
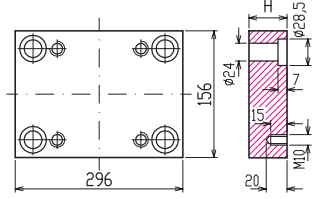

**KOLONLAR / PILLARS**

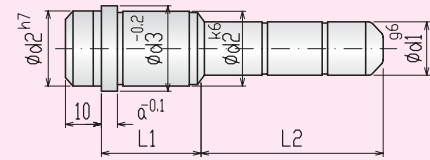

K S K K				L2													
d1	d2	d3	a	L1	26	36	46	56	66	76	86	96	106	116	126	136	146
16	24	28	6	26													
				36													
				46													
				56													
				66													
				76													
				86													
				96													
				106													
				116													
				126													
				136													
				146													

**BURÇLAR / GUIDE BUSHES**

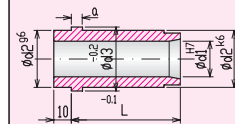

K S B I				L						
d1	d2	d3	a	26	36	46	56	66	76	86
16	24	28	6							

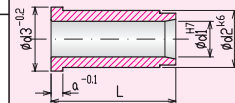

S B I				L						
d1	d2	d3	a	26	36	46	56	66	76	86
16	24	28	6							

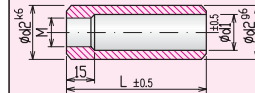

D T B I				L					
d1	d2	M	a	60	80	100	120	140	160
16	24	M8							

**ÇİVATALAR / SOCKET CAP SCREWS**

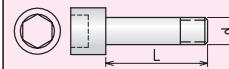

DIN 912 12.9

d	L	20	25	30	35	40	45	50	60	70	80	90	100	110	120	130	140	150	160	180	200	220	240	260	280
M8																									
M10																									

**YAYLI RONDELA / SPRING WASHER**

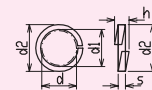

h <sub>max</sub>	d1	d2	d	s
5.9	10.2	16	10	2.5



# Enjeksiyon Kalıp Seti Kuyruklu 196 Serisi

## Injection Mold Base 196 Series with Locating Pillar

ek  
196

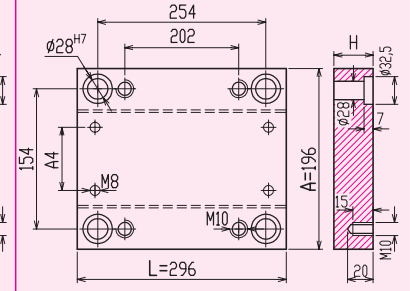
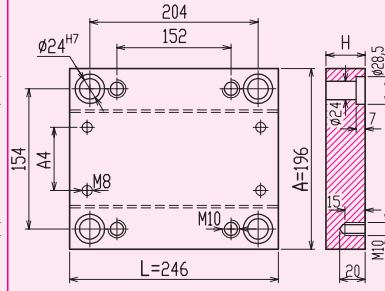
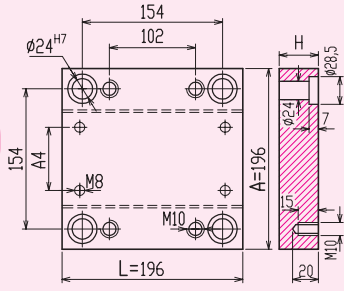

Plakalar / Plates	H	EK1919	EK1924	EK1929									
 H1 H2	27												
	37												
	47												
	57												
	67												
	77												
 H6	27												
	37												
	47												
	57												
	67												
	77												
 H4	27												
	37												
	47												
 H3	57												
	67												
	77												
 H5 H9	27												
	37												
 H7	14												
	17												
	<table border="1"> <tr> <td>A5</td> <td>A3</td> <td>A4</td> </tr> <tr> <td>37</td> <td>120</td> <td>98</td> </tr> <tr> <td>47</td> <td>100</td> <td>78</td> </tr> </table>				A5	A3	A4	37	120	98	47	100	78
A5	A3	A4											
37	120	98											
47	100	78											
 H8	17												
	<table border="1"> <tr> <td>A5</td> <td>A3</td> <td>A4</td> </tr> <tr> <td>37</td> <td>120</td> <td>98</td> </tr> <tr> <td>47</td> <td>100</td> <td>78</td> </tr> </table>				A5	A3	A4	37	120	98	47	100	78
	A5				A3	A4							
37	120	98											
47	100	78											
<table border="1"> <tr> <td>A5</td> <td>A3</td> <td>A4</td> </tr> <tr> <td>37</td> <td>120</td> <td>98</td> </tr> <tr> <td>47</td> <td>100</td> <td>78</td> </tr> </table>	A5	A3	A4	37	120	98	47	100	78				
A5	A3	A4											
37	120	98											
47	100	78											



# Enjeksiyon Kalıp Seti Kuyruklu 196 Serisi

## Injection Mold Base 196 Series with Locating Pillar

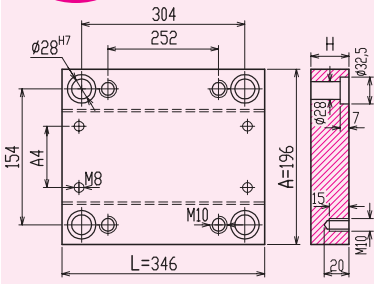

EK1934

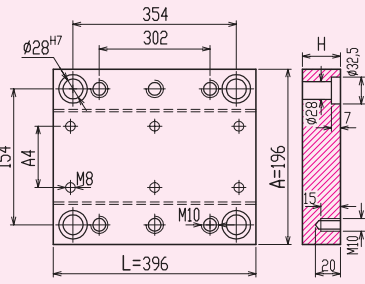

EK1939

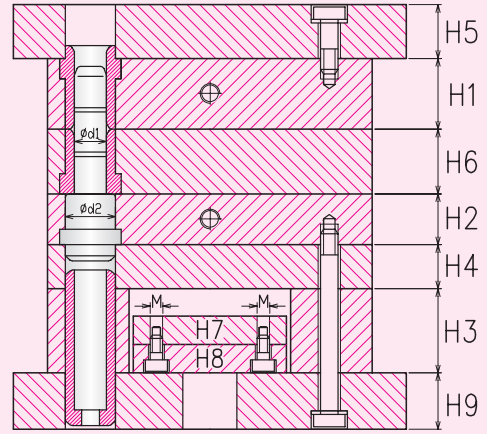
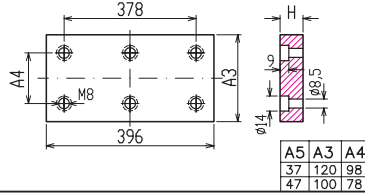
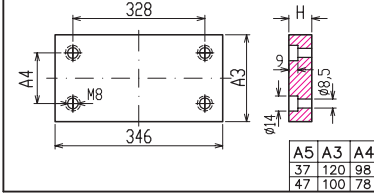
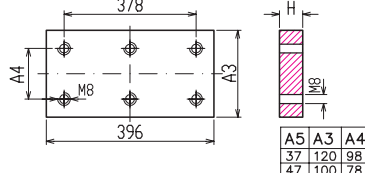
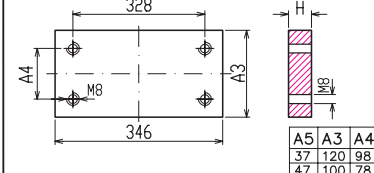
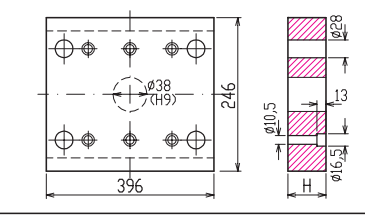
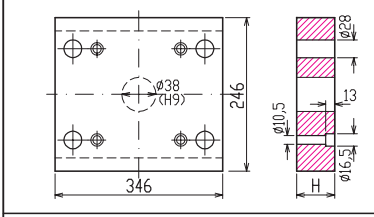
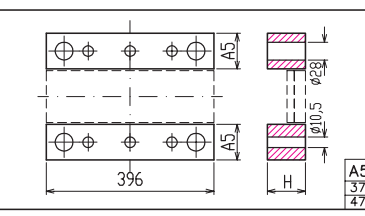
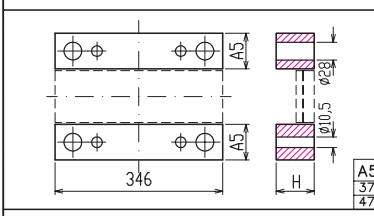
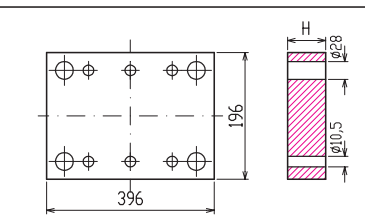
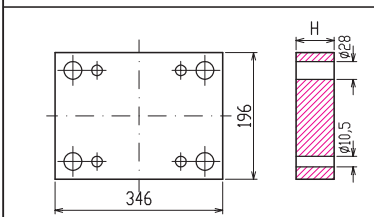
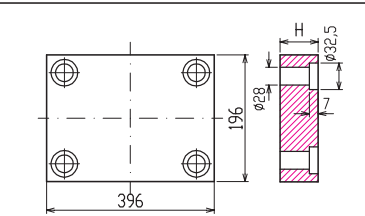
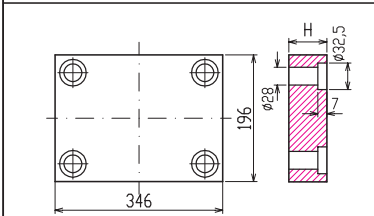
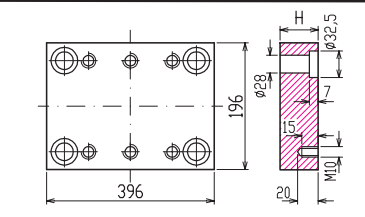
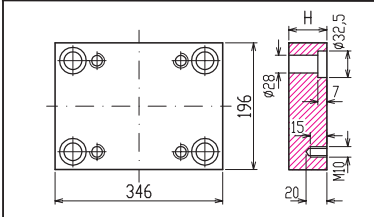

### KOLONLAR / PILLARS

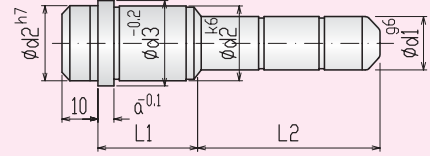

K S K K			L2																	
d1	d2	d3	a	L1	26	36	46	56	66	76	86	96	106	116	126	136	146			
16	24	28	6	26																
				36																
				46																
				56																
				66																
				76																
20	28	32	6	86																
				96																
				106																
				116																
				126																
				136																

### BURÇLAR / GUIDE BUSHES

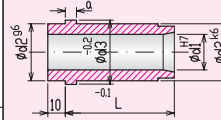

K S B			L								
d1	d2	d3	a	26	36	46	56	66	76	86	96
16	24	28	6								
20	28	32	6								

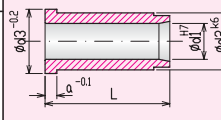

S B			L								
d1	d2	d3	a	26	36	46	56	66	76	86	96
16	24	28	6								
20	28	32	6								

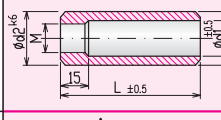

D T B			L					
d1	d2	M	60	80	100	120	140	160
16	24	M8						
20	28	M8						

### ÇİVATALAR / SOCKET CAP SCREWS

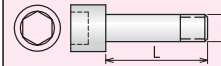

DIN 912 12.9

d	L	20	25	30	35	40	45	50	60	70	80	90	100	110	120	130	140	150	160	180	200	220	240	260	280	
M8																										
M10																										

### YAYLI RONDELA / SPRING WASHER

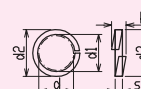

h <sub>max</sub>	d <sub>1</sub>	d <sub>2</sub>	d	s
5.9	10.2	16	10	2.5



# Enjeksiyon Kalıp Seti Kuyruklu 246 Serisi Injection Mold Base 246 Series with Locating Pillar

ek  
246

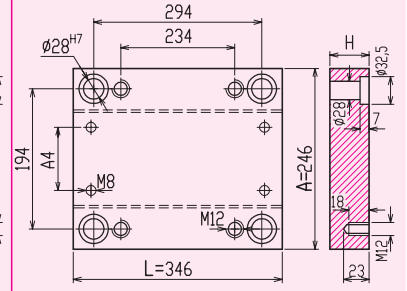
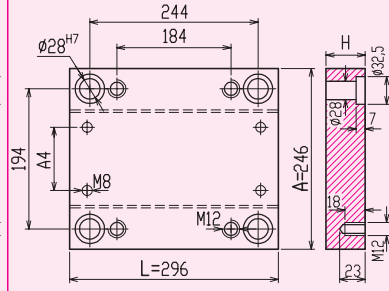
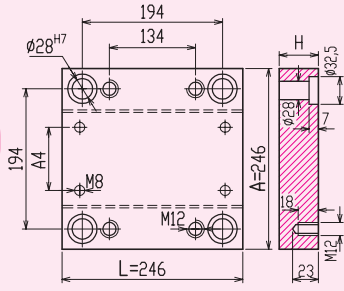

Plakalar / Plates	H	EK2424	EK2429	EK2434
 H1 H2	27	 246 246 23 H 28 32.5 7 M12	 296 296 23 H 28 32.5 7 M12	 346 346 23 H 28 32.5 7 M12
	37			
	47			
	57			
	67			
	77			
	87			
97				
 H6	27	 246 246 23 H 28 32.5 7	 296 296 23 H 28 32.5 7	 346 346 23 H 28 32.5 7
	37			
	47			
	57			
	97			
 H4	27	 246 246 23 H 28 32.5	 296 296 23 H 28 32.5	 346 346 23 H 28 32.5
	37			
	47			
 H3	57	 246 246 23 H 28 32.5 A5 47 57	 296 296 23 H 28 32.5 A5 47 57	 346 346 23 H 28 32.5 A5 47 57
	67			
	77			
	87			
	97			
 H5 H9	27	 246 246 23 H 28 32.5 15 38 39 A5 47 57	 296 296 23 H 28 32.5 15 38 39 A5 47 57	 346 346 23 H 28 32.5 15 38 39 A5 47 57
	37			
 H7	14	 246 246 23 H 28 32.5 A4 A3 A5 47 148 130 57 128 110	 296 296 23 H 28 32.5 A4 A3 A5 47 148 130 57 128 110	 346 346 23 H 28 32.5 A4 A3 A5 47 148 130 57 128 110
	17			
 H8	14	 246 246 23 H 28 32.5 A4 A3 A5 47 148 130 57 128 110	 296 296 23 H 28 32.5 A4 A3 A5 47 148 130 57 128 110	 346 346 23 H 28 32.5 A4 A3 A5 47 148 130 57 128 110
	17			



# Enjeksiyon Kalıp Seti Kuyruklu 246 Serisi Injection Mold Base 246 Series with Locating Pillar

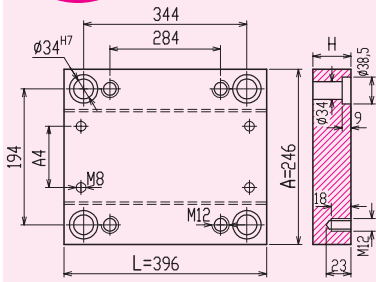

EK2439

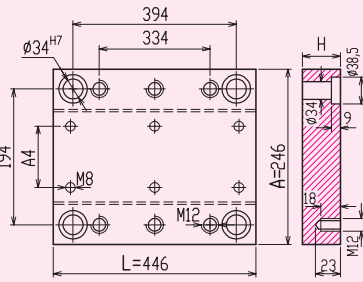

EK2444

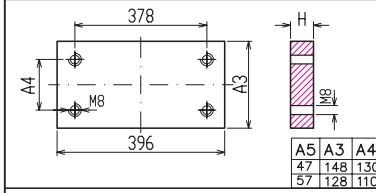
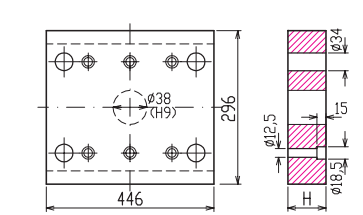
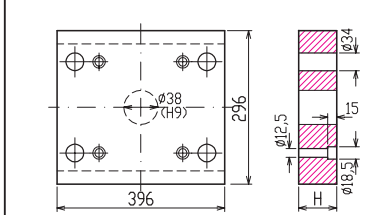
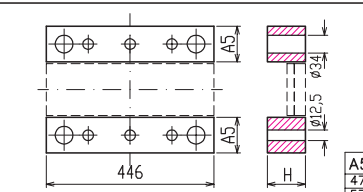
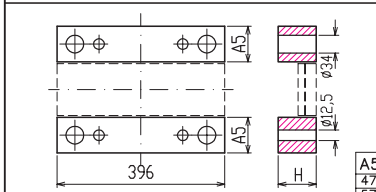
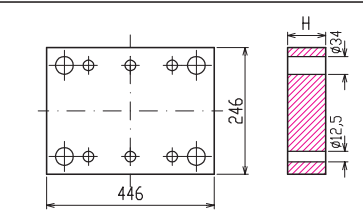
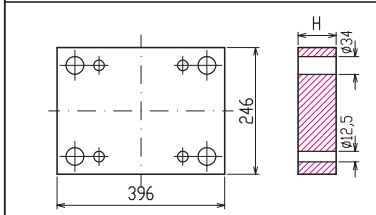
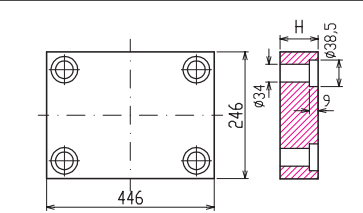
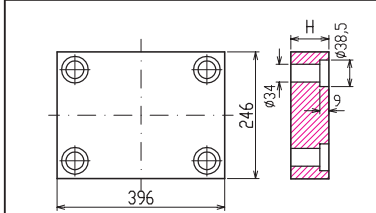
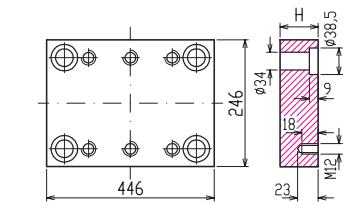
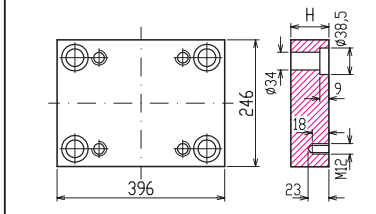

A5	A3	A4
47	148	130
57	128	110

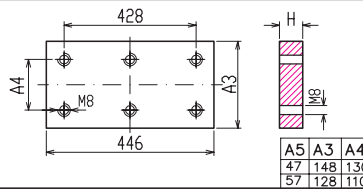

A5	A3	A4
47	148	130
57	128	110

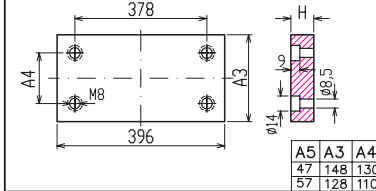

A5	A3	A4
47	148	130
57	128	110

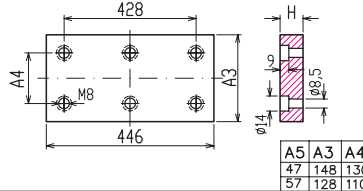

A5	A3	A4
47	148	130
57	128	110

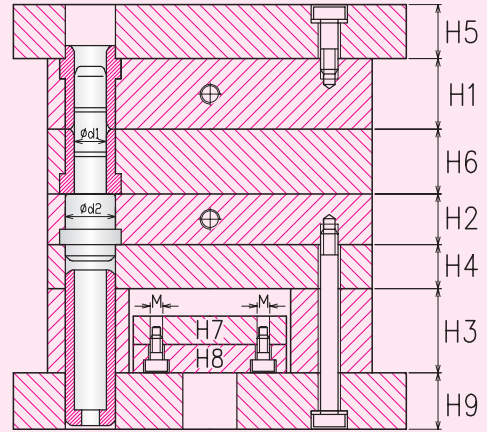

## KOLONLAR / PILLARS

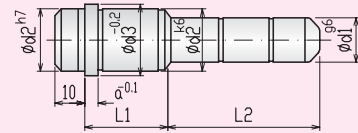

K S K K				L																
d1	d2	d3	a	L1	26	36	46	56	66	76	86	96	106	116	126	136	146			
20	28	32	6	26																
				36																
				46																
				56																
				66																
				76																
25	34	38	8	26																
				36																
				46																
				56																
				66																
				76																

## BURÇLAR / GUIDE BUSHES

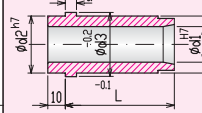

K S B				L								
d1	d2	d3	a	26	36	46	56	66	76	86	96	106
20	28	32	6									
25	34	38	8									

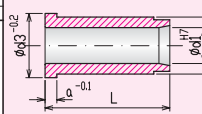

S B				L								
d1	d2	d3	a	26	36	46	56	66	76	86	96	106
20	28	32	6									
25	34	38	8									

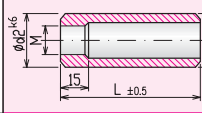

D T B			L					
d1	d2	M	60	80	100	120	140	160
20	28	M8						
25	34	M10						

## ÇİVATALAR / SOCKET CAP SCREWS

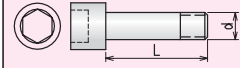

DIN 912 12.9

d	20	25	30	35	40	45	50	60	70	80	90	100	110	120	130	140	150	160	180	200	220	240	260	280	
M8																									
M12																									

## YAYLI RONDELA / SPRING WASHER

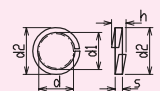

h <sub>max</sub>	d1	d2	d	s
5.9	12.2	18	12	2.5



# Enjeksiyon Kalıp Seti Kuyruklu 296 Serisi

## Injection Mold Base 296 Series with Locating Pillar

ek  
296

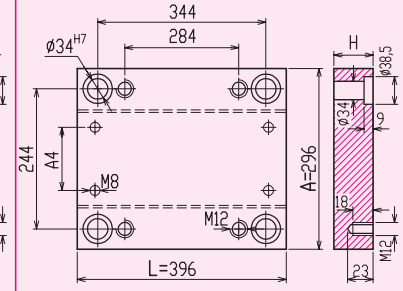
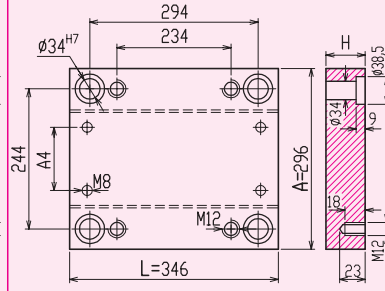
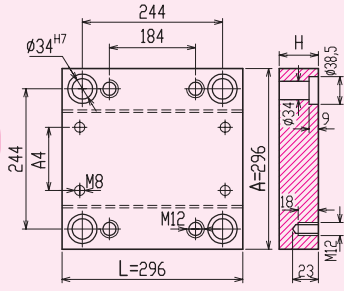

Plakalar / Plates	H	EK2929	EK2934	EK2939																													
<b>H1-H2</b> 	27																																
	37																																
	47																																
	57																																
	67																																
	77																																
	87																																
<b>H6</b> 	27																																
	37																																
	47																																
	57																																
	67																																
<b>H4</b> 	27																																
	37																																
	47																																
	57																																
<b>H3</b> 	57																																
	67																																
	77																																
	87																																
	97																																
<b>H5-H9</b> 	27																																
	37																																
<b>H7</b> 	17																																
	22																																
	<table border="1"> <tr><td>A5</td><td>A3</td><td>A4</td></tr> <tr><td>47</td><td>198</td><td>180</td></tr> <tr><td>57</td><td>178</td><td>160</td></tr> </table>				A5	A3	A4	47	198	180	57	178	160	<table border="1"> <tr><td>A5</td><td>A3</td><td>A4</td></tr> <tr><td>47</td><td>198</td><td>180</td></tr> <tr><td>57</td><td>178</td><td>160</td></tr> </table>	A5	A3	A4	47	198	180	57	178	160	<table border="1"> <tr><td>A5</td><td>A3</td><td>A4</td></tr> <tr><td>47</td><td>198</td><td>180</td></tr> <tr><td>57</td><td>178</td><td>160</td></tr> </table>	A5	A3	A4	47	198	180	57	178	160
	A5				A3	A4																											
47	198	180																															
57	178	160																															
A5	A3	A4																															
47	198	180																															
57	178	160																															
A5	A3	A4																															
47	198	180																															
57	178	160																															
<table border="1"> <tr><td>A5</td><td>A3</td><td>A4</td></tr> <tr><td>47</td><td>198</td><td>180</td></tr> <tr><td>57</td><td>178</td><td>160</td></tr> </table>	A5	A3	A4	47	198	180	57	178	160	<table border="1"> <tr><td>A5</td><td>A3</td><td>A4</td></tr> <tr><td>47</td><td>198</td><td>180</td></tr> <tr><td>57</td><td>178</td><td>160</td></tr> </table>	A5	A3	A4	47	198	180	57	178	160	<table border="1"> <tr><td>A5</td><td>A3</td><td>A4</td></tr> <tr><td>47</td><td>198</td><td>180</td></tr> <tr><td>57</td><td>178</td><td>160</td></tr> </table>	A5	A3	A4	47	198	180	57	178	160				
A5	A3	A4																															
47	198	180																															
57	178	160																															
A5	A3	A4																															
47	198	180																															
57	178	160																															
A5	A3	A4																															
47	198	180																															
57	178	160																															
<b>H8</b> 	22																																
	<table border="1"> <tr><td>A5</td><td>A3</td><td>A4</td></tr> <tr><td>47</td><td>198</td><td>180</td></tr> <tr><td>57</td><td>178</td><td>160</td></tr> </table>				A5	A3	A4	47	198	180	57	178	160	<table border="1"> <tr><td>A5</td><td>A3</td><td>A4</td></tr> <tr><td>47</td><td>198</td><td>180</td></tr> <tr><td>57</td><td>178</td><td>160</td></tr> </table>	A5	A3	A4	47	198	180	57	178	160	<table border="1"> <tr><td>A5</td><td>A3</td><td>A4</td></tr> <tr><td>47</td><td>198</td><td>180</td></tr> <tr><td>57</td><td>178</td><td>160</td></tr> </table>	A5	A3	A4	47	198	180	57	178	160
	A5				A3	A4																											
	47				198	180																											
57	178	160																															
A5	A3	A4																															
47	198	180																															
57	178	160																															
A5	A3	A4																															
47	198	180																															
57	178	160																															
<table border="1"> <tr><td>A5</td><td>A3</td><td>A4</td></tr> <tr><td>47</td><td>198</td><td>180</td></tr> <tr><td>57</td><td>178</td><td>160</td></tr> </table>	A5	A3	A4	47	198	180	57	178	160	<table border="1"> <tr><td>A5</td><td>A3</td><td>A4</td></tr> <tr><td>47</td><td>198</td><td>180</td></tr> <tr><td>57</td><td>178</td><td>160</td></tr> </table>	A5	A3	A4	47	198	180	57	178	160	<table border="1"> <tr><td>A5</td><td>A3</td><td>A4</td></tr> <tr><td>47</td><td>198</td><td>180</td></tr> <tr><td>57</td><td>178</td><td>160</td></tr> </table>	A5	A3	A4	47	198	180	57	178	160				
A5	A3	A4																															
47	198	180																															
57	178	160																															
A5	A3	A4																															
47	198	180																															
57	178	160																															
A5	A3	A4																															
47	198	180																															
57	178	160																															
<table border="1"> <tr><td>A5</td><td>A3</td><td>A4</td></tr> <tr><td>47</td><td>198</td><td>180</td></tr> <tr><td>57</td><td>178</td><td>160</td></tr> </table>	A5	A3	A4	47	198	180	57	178	160	<table border="1"> <tr><td>A5</td><td>A3</td><td>A4</td></tr> <tr><td>47</td><td>198</td><td>180</td></tr> <tr><td>57</td><td>178</td><td>160</td></tr> </table>	A5	A3	A4	47	198	180	57	178	160	<table border="1"> <tr><td>A5</td><td>A3</td><td>A4</td></tr> <tr><td>47</td><td>198</td><td>180</td></tr> <tr><td>57</td><td>178</td><td>160</td></tr> </table>	A5	A3	A4	47	198	180	57	178	160				
A5	A3	A4																															
47	198	180																															
57	178	160																															
A5	A3	A4																															
47	198	180																															
57	178	160																															
A5	A3	A4																															
47	198	180																															
57	178	160																															





# Enjeksiyon Kalıp Seti Kuyruklu 296 Serisi

## Injection Mold Base 296 Series with Locating Pillar

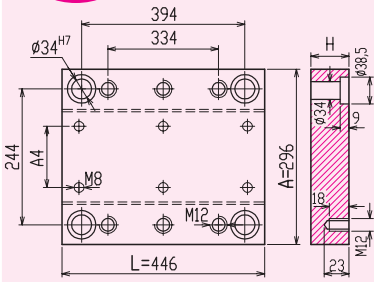

EK2944

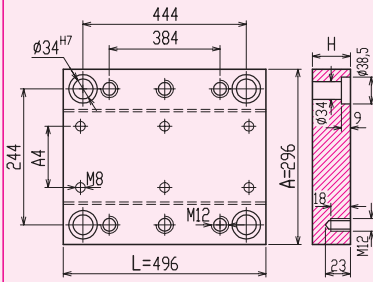

EK2949

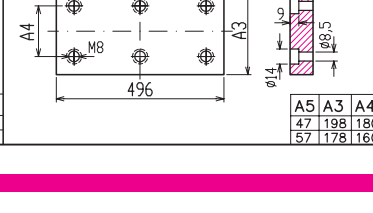
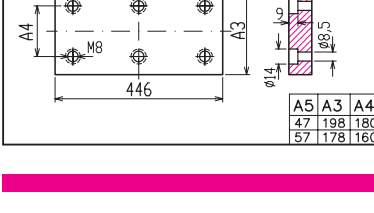
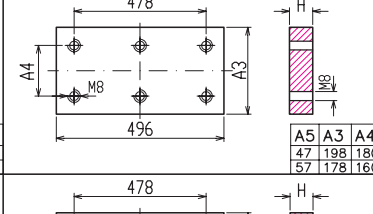
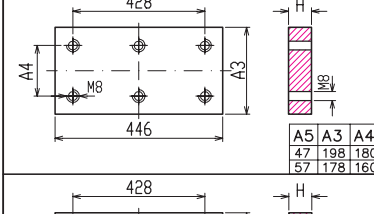
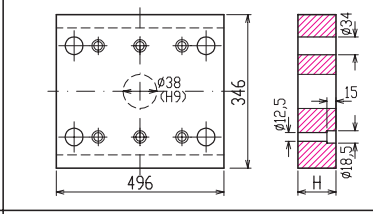
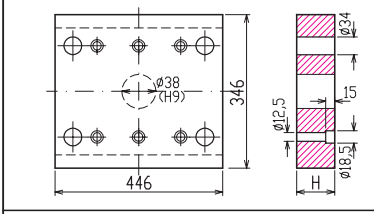
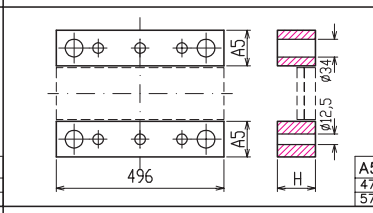
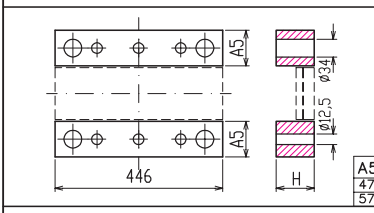
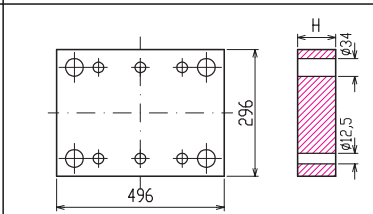
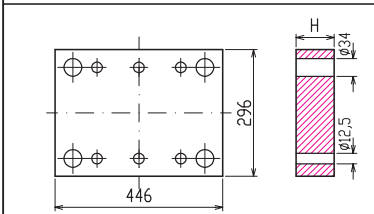
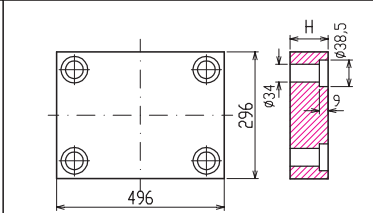
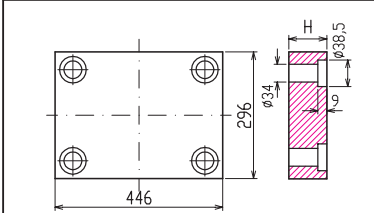
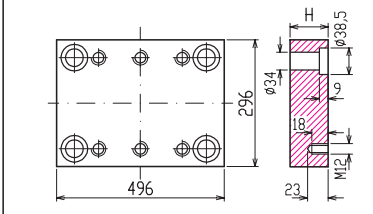
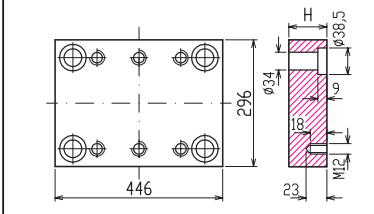
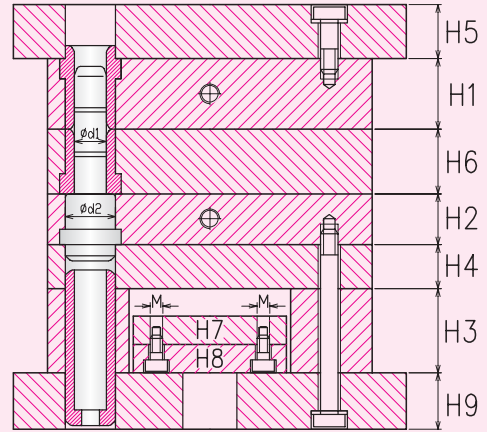

### KOLONLAR / PILLARS

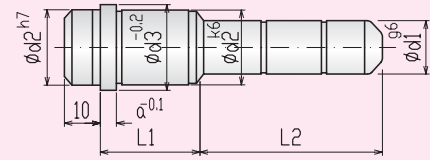

K S K K				L2												
d1	d2	d3	a	L1	36	46	56	66	76	86	96	106	116	126	136	146
25	34	38	8	26												
				36												
				46												
				56												
				66												
				76												
				86												
				96												
				106												

### BURÇLAR / GUIDE BUSHES

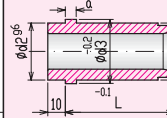

K S B				L										
d1	d2	d3	a	26	36	46	56	66	76	86	96	106		
25	34	38	8											

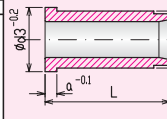

S B				L										
d1	d2	d3	a	26	36	46	56	66	76	86	96	106		
25	34	38	8											

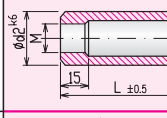

D T B				L										
d1	d2	M	a	60	80	100	120	140	160					
25	34	M10												

### ÇİVATALAR / SOCKET CAP SCREWS

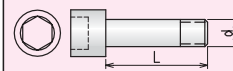

DIN 912 12.9

d	L	20	25	30	35	40	45	50	60	70	80	90	100	110	120	130	140	150	160	180	200	220	240	260	280
M8																									
M12																									

### YAYLI RONDELA / SPRING WASHER

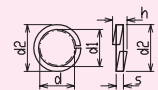

$h_{max}$	d1	d2	d	s
5.9	12.2	18	12	2.5



# Enjeksiyon Kalıp Seti Kuyruklu 346 Serisi

## Injection Mold Base 346 Series with Locating Pillar

ek  
346

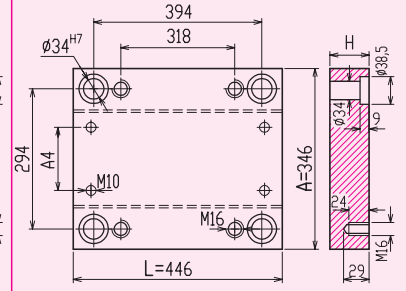
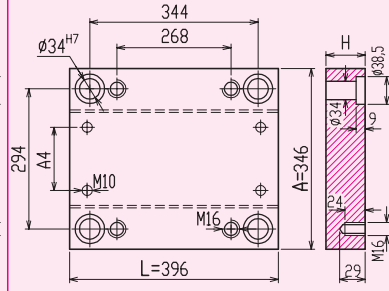
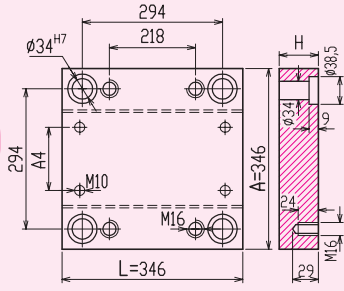

Plakalar / Plates	H	EK3434	EK3439	EK3444																													
<b>H1-H2</b> 	37																																
	47																																
	57																																
	67																																
	77																																
	87																																
	97																																
<b>H6</b> 	27																																
	37																																
	47																																
	57																																
	67																																
	77																																
	87																																
<b>H4</b> 	27																																
	37																																
	47																																
	57																																
<b>H3</b> 	57																																
	67																																
	77																																
	87																																
	97																																
<b>H5-H9</b> 	37																																
	47																																
<b>H7</b> 	17																																
	22																																
	<table border="1"> <tr><td>A5</td><td>A3</td><td>A4</td></tr> <tr><td>47</td><td>248</td><td>224</td></tr> <tr><td>57</td><td>228</td><td>204</td></tr> </table>				A5	A3	A4	47	248	224	57	228	204	<table border="1"> <tr><td>A5</td><td>A3</td><td>A4</td></tr> <tr><td>47</td><td>248</td><td>224</td></tr> <tr><td>57</td><td>228</td><td>204</td></tr> </table>	A5	A3	A4	47	248	224	57	228	204	<table border="1"> <tr><td>A5</td><td>A3</td><td>A4</td></tr> <tr><td>47</td><td>248</td><td>224</td></tr> <tr><td>57</td><td>228</td><td>204</td></tr> </table>	A5	A3	A4	47	248	224	57	228	204
	A5				A3	A4																											
	47				248	224																											
57	228	204																															
A5	A3	A4																															
47	248	224																															
57	228	204																															
A5	A3	A4																															
47	248	224																															
57	228	204																															
<b>H8</b> 	22																																
	<table border="1"> <tr><td>A5</td><td>A3</td><td>A4</td></tr> <tr><td>47</td><td>248</td><td>224</td></tr> <tr><td>57</td><td>228</td><td>204</td></tr> </table>				A5	A3	A4	47	248	224	57	228	204	<table border="1"> <tr><td>A5</td><td>A3</td><td>A4</td></tr> <tr><td>47</td><td>248</td><td>224</td></tr> <tr><td>57</td><td>228</td><td>204</td></tr> </table>	A5	A3	A4	47	248	224	57	228	204	<table border="1"> <tr><td>A5</td><td>A3</td><td>A4</td></tr> <tr><td>47</td><td>248</td><td>224</td></tr> <tr><td>57</td><td>228</td><td>204</td></tr> </table>	A5	A3	A4	47	248	224	57	228	204
	A5				A3	A4																											
	47				248	224																											
	57				228	204																											
A5	A3	A4																															
47	248	224																															
57	228	204																															
A5	A3	A4																															
47	248	224																															
57	228	204																															



# Enjeksiyon Kalıp Seti Kuyruklu 346 Serisi

## Injection Mold Base 346 Series with Locating Pillar

EKS EK Serisi

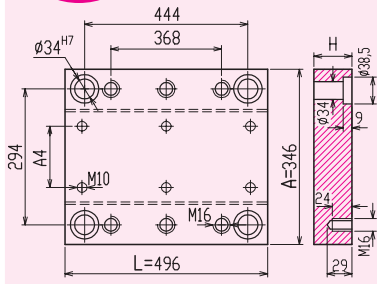

EK3449

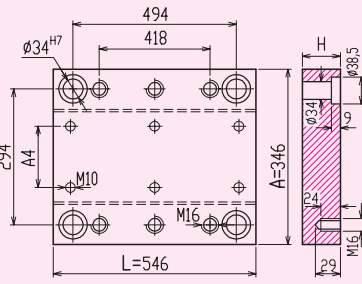

EK3454

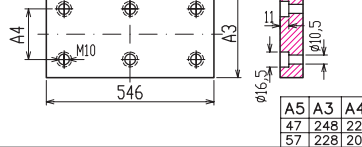
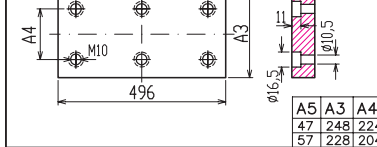
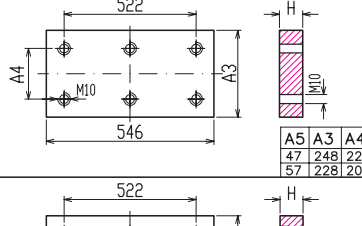
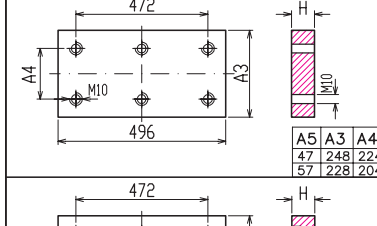
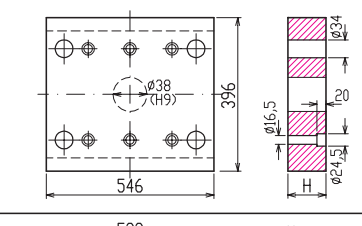
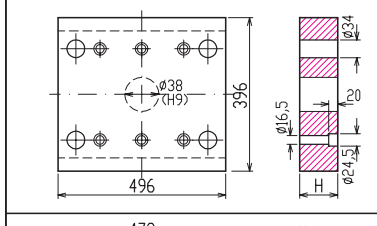
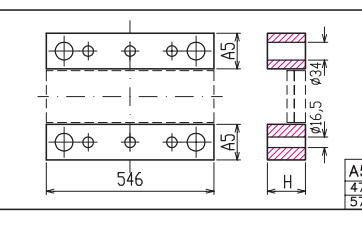
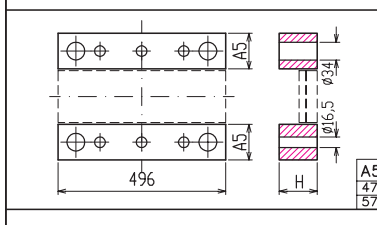
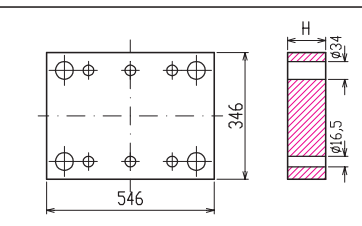
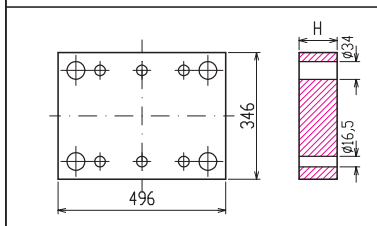
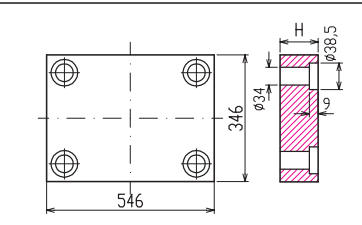
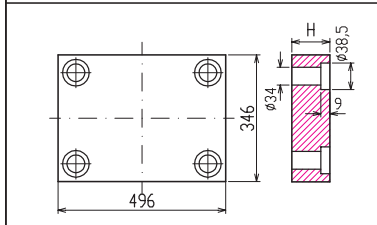
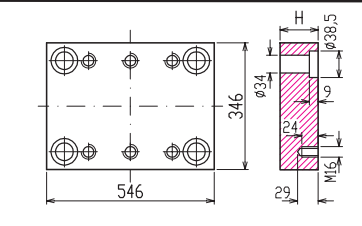
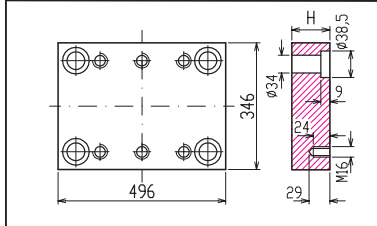
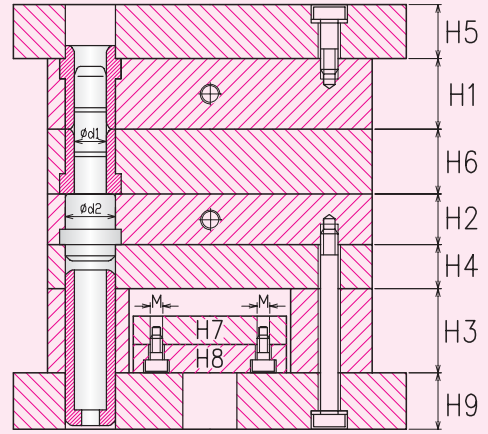

### KOLONLAR / PILLARS

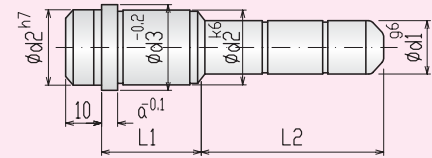

K S K K				L2												
d1	d2	d3	a	L1	36	46	56	66	76	86	96	106	116	126	136	146
25	34	38	8	26	36	46	56	66	76	86	96	106	116	126	136	146
				36	46	56	66	76	86	96	106	116	126	136	146	
				46	56	66	76	86	96	106	116	126	136	146		
				56	66	76	86	96	106	116	126	136	146			
				66	76	86	96	106	116	126	136	146				
				76	86	96	106	116	126	136	146					
				86	96	106	116	126	136	146						
				96	106	116	126	136	146							
				106	116	126	136	146								

### BURÇLAR / GUIDE BUSHES

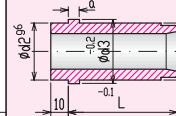

K S B				L										
d1	d2	d3	a	26	36	46	56	66	76	86	96	106		
25	34	38	8	26	36	46	56	66	76	86	96	106		

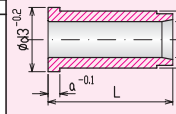

S B				L										
d1	d2	d3	a	26	36	46	56	66	76	86	96	106		
25	34	38	8	26	36	46	56	66	76	86	96	106		

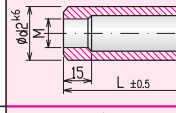

D T B			L					
d1	d2	M	60	80	100	120	140	160
25	34	M10	60	80	100	120	140	160

### ÇİVATALAR / SOCKET CAP SCREWS

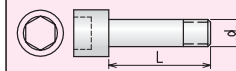

DIN 912 12.9

d	L	20	25	30	35	40	45	50	60	70	80	90	100	110	120	130	140	150	160	180	200	220	240	260	280	
M10																										
M16																										

### YAYLI RONDELA / SPRING WASHER

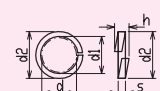

$h_{max}$	d1	d2	d	s
8.3	16.2	24.4	16	3.5



# Enjeksiyon Kalıp Seti Kuyruklu 396 Serisi

## Injection Mold Base 396 Series with Locating Pillar

ek  
396

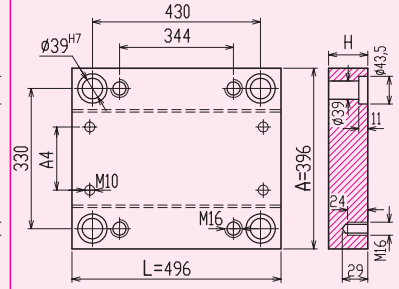
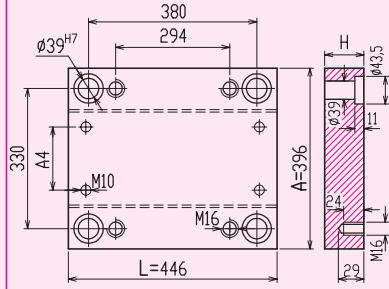
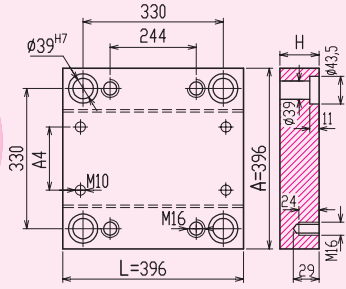

Plakalar / Plates	H	EK3939	EK3944	EK3949									
<b>H1-H2</b> 	37												
	47												
	57												
	67												
	77												
	87												
	97												
<b>H6</b> 	37												
	47												
	57												
	67												
	77												
<b>H4</b> 	27												
	37												
	47												
	57												
<b>H3</b> 	77												
	87												
	97												
	107												
	117												
<b>H5-H9</b> 	37												
	47												
	57												
<b>H7</b> 	22												
	27												
	<table border="1"> <tr><td>A5</td><td>A3</td><td>A4</td></tr> <tr><td>57</td><td>276</td><td>252</td></tr> <tr><td>67</td><td>256</td><td>232</td></tr> </table>				A5	A3	A4	57	276	252	67	256	232
A5	A3	A4											
57	276	252											
67	256	232											
<b>H8</b> 	27												
	<table border="1"> <tr><td>A5</td><td>A3</td><td>A4</td></tr> <tr><td>57</td><td>276</td><td>252</td></tr> <tr><td>67</td><td>256</td><td>232</td></tr> </table>				A5	A3	A4	57	276	252	67	256	232
	A5				A3	A4							
57	276	252											
67	256	232											
<table border="1"> <tr><td>A5</td><td>A3</td><td>A4</td></tr> <tr><td>57</td><td>276</td><td>252</td></tr> <tr><td>67</td><td>256</td><td>232</td></tr> </table>	A5	A3	A4	57	276	252	67	256	232				
A5	A3	A4											
57	276	252											
67	256	232											



# Enjeksiyon Kalıp Seti Kuyruklu 396 Serisi

## Injection Mold Base 396 Series with Locating Pillar

EKS EK Serisi

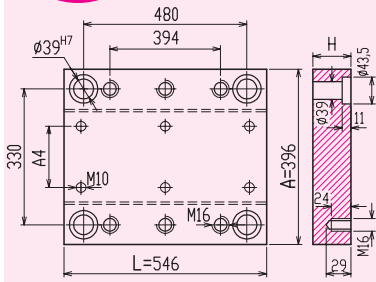

EK3954

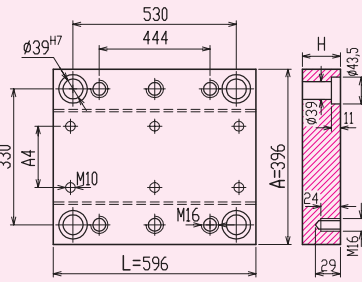

EK3959

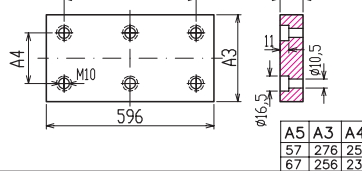
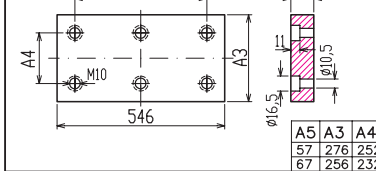
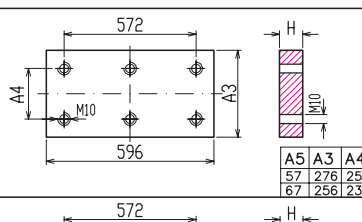
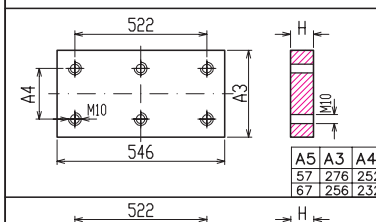
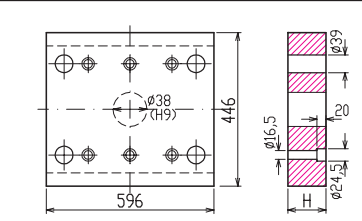
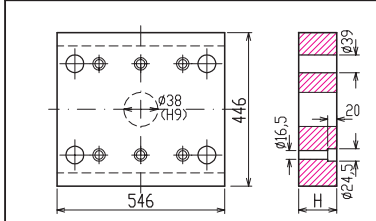
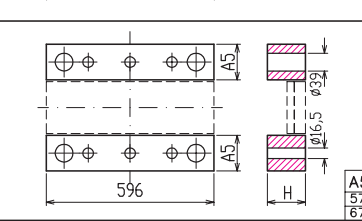
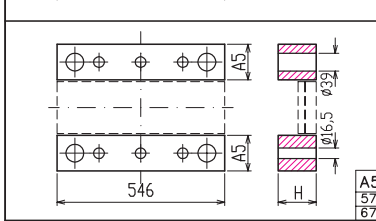
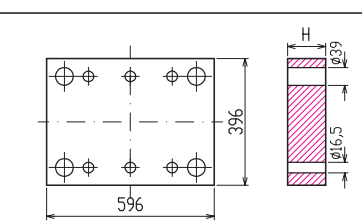
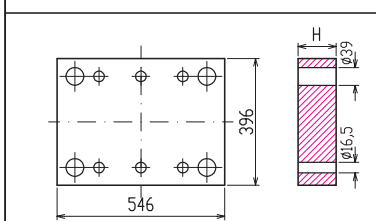
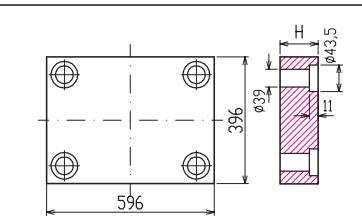
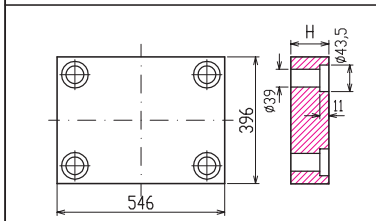
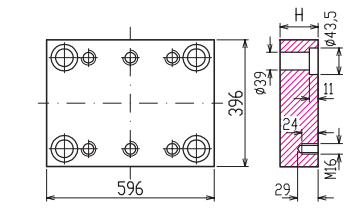
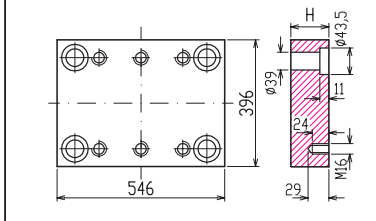
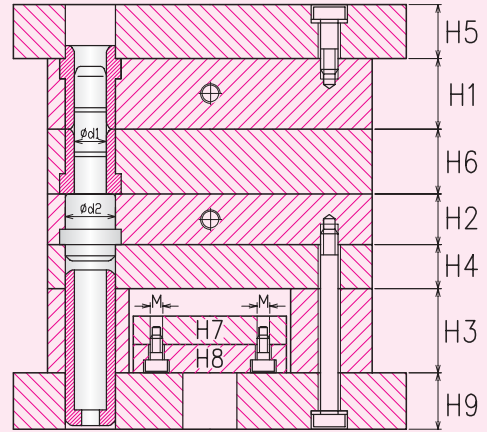

### KOLONLAR / PILLARS

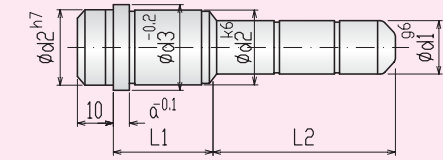

K S K K				L2											
d1	d2	d3	a	L1	36	46	56	66	76	86	96	106	116	126	136
30	39	43	10	36											
				46											
				56											
				66											
				76											
				86											
				96											
				106											
				116											

### BURÇLAR / GUIDE BUSHES

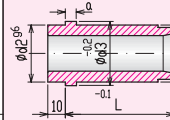

K S B				L									
d1	d2	d3	a	36	46	56	66	76	86	96	106	116	
30	39	43	10										

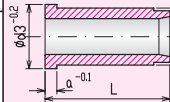

S B				L									
d1	d2	d3	a	36	46	56	66	76	86	96	106	116	
30	39	43	10										

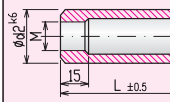

D T B				L				
d1	d2	M	d	80	100	120	140	160
30	39	M10						

### ÇİVATALAR / SOCKET CAP SCREWS

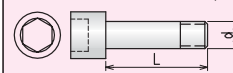

DIN 912 12.9

d	20	25	30	35	40	45	50	60	70	80	90	100	110	120	130	140	150	160	180	200	220	240	260	280
M10																								
M16																								

### YAYLI RONDELA / SPRING WASHER

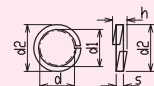

$h_{max}$	$d_1$	$d_2$	$d$	$s$
8.3	16.2	24.4	16	3.5



# Enjeksiyon Kalıp Seti Kuyruklu 446 Serisi

## Injection Mold Base 446 Series with Locating Pillar

ek  
446

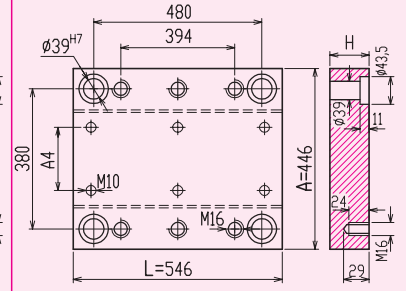
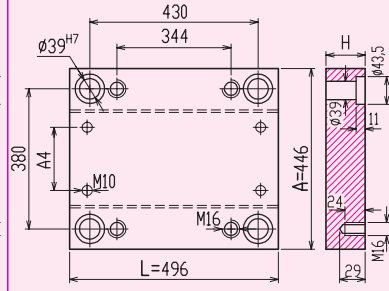
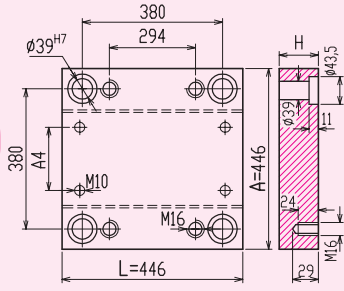

Plakalar / Plates	H	EK4444	EK4449	EK4454									
<b>H1-H2</b> 	37												
	47												
	57												
	67												
	77												
	87												
	97												
<b>H6</b> 	37												
	47												
	57												
	67												
	77												
	87												
	97												
<b>H4</b> 	37												
	47												
	57												
	67												
<b>H3</b> 	77												
	87												
	97												
	107												
	117												
<b>H5-H9</b> 	37												
	47												
	57												
<b>H7</b> 	22												
	27												
	<table border="1"> <tr><td>A5</td><td>A3</td><td>A4</td></tr> <tr><td>57</td><td>326</td><td>302</td></tr> <tr><td>77</td><td>286</td><td>262</td></tr> </table>				A5	A3	A4	57	326	302	77	286	262
A5	A3	A4											
57	326	302											
77	286	262											
<b>H8</b> 	27												
	<table border="1"> <tr><td>A5</td><td>A3</td><td>A4</td></tr> <tr><td>57</td><td>326</td><td>302</td></tr> <tr><td>77</td><td>286</td><td>262</td></tr> </table>				A5	A3	A4	57	326	302	77	286	262
	A5				A3	A4							
57	326	302											
77	286	262											
<table border="1"> <tr><td>A5</td><td>A3</td><td>A4</td></tr> <tr><td>57</td><td>326</td><td>302</td></tr> <tr><td>77</td><td>286</td><td>262</td></tr> </table>	A5	A3	A4	57	326	302	77	286	262				
A5	A3	A4											
57	326	302											
77	286	262											



# Enjeksiyon Kalıp Seti Kuyruklu 446 Serisi Injection Mold Base 446 Series with Locating Pillar

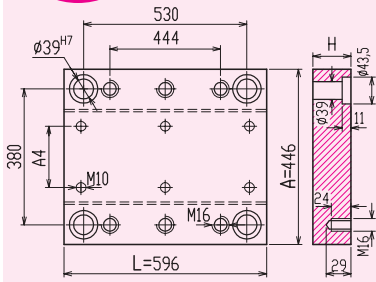

EK4459

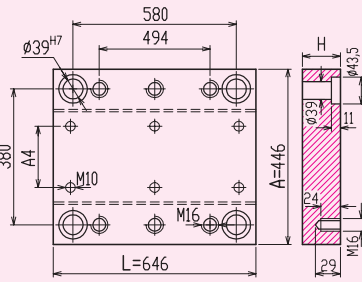

EK4464

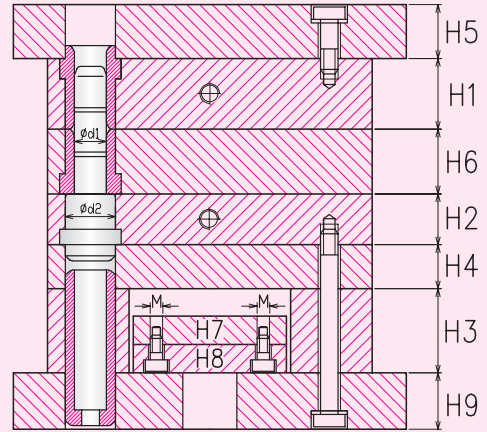

EKS EK Serisi

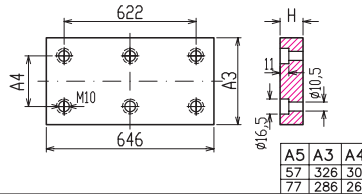
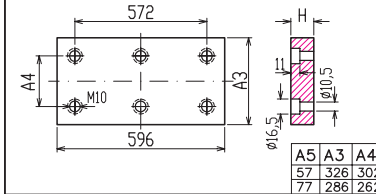
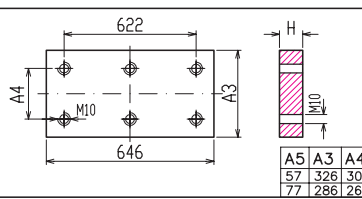
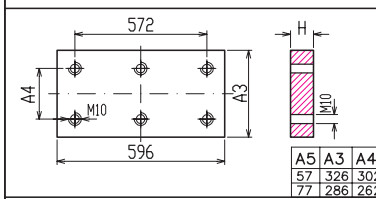
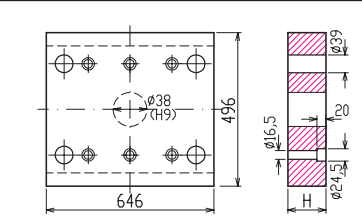
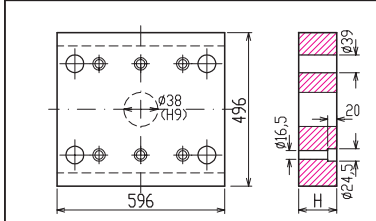
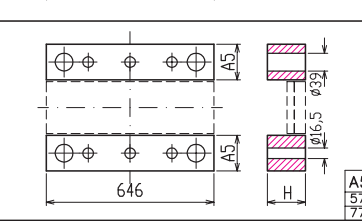
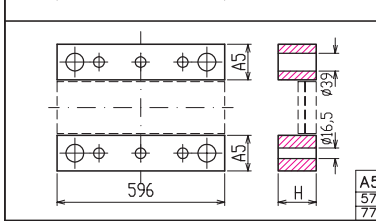
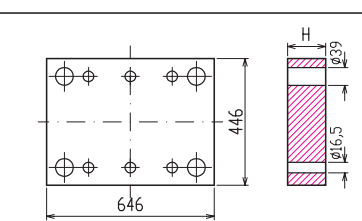
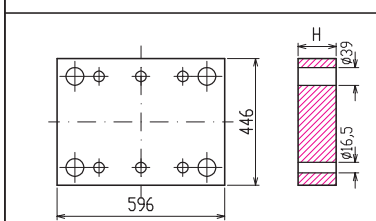
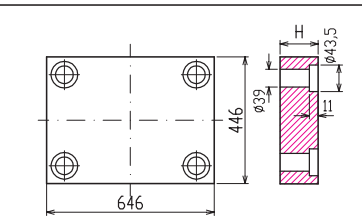
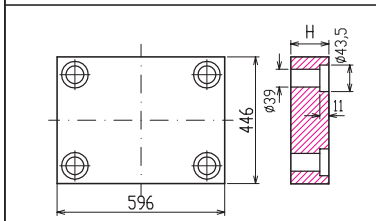
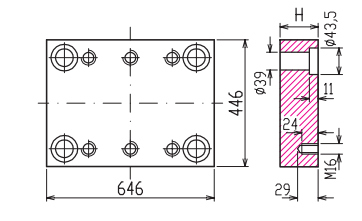
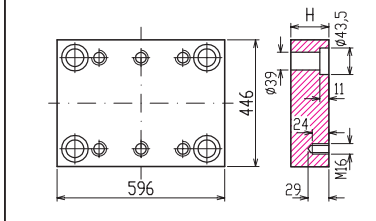

## KOLONLAR / PILLARS

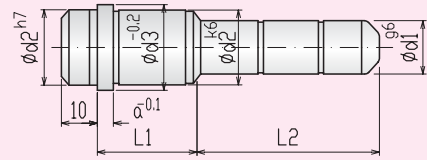

K S K K				L2											
d1	d2	d3	a	L1	36	46	56	66	76	86	96	106	116	126	136
30	39	43	10	36											
				46											
				56											
				66											
				76											
				86											
				96											
				106											
				116											

## BURÇLAR / GUIDE BUSHES

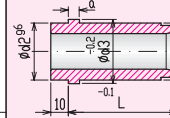

K S B				L									
d1	d2	d3	a	36	46	56	66	76	86	96	106	116	
30	39	43	10										

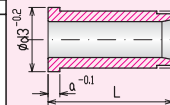

S B				L									
d1	d2	d3	a	36	46	56	66	76	86	96	106	116	
30	39	43	10										

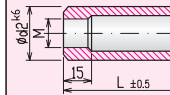

D T B				L				
d1	d2	M	a	80	100	120	140	160
30	39	M10						

## ÇİVATALAR / SOCKET CAP SCREWS

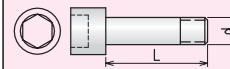

DIN 912 12.9

d	L	20	25	30	35	40	45	50	60	70	80	90	100	110	120	130	140	150	160	180	200	220	240	260	280
M10																									
M16																									

## YAYLI RONDELA / SPRING WASHER

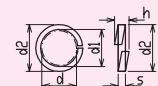

$h_{max}$	d1	d2	d	s
8.3	16.2	24.4	16	3.5



# Enjeksiyon Kalıp Seti Kuyruklu 496 Serisi

## Injection Mold Base 496 Series with Locating Pillar

ek  
496

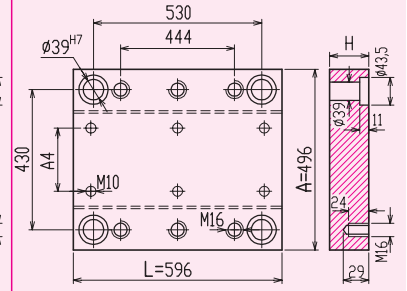
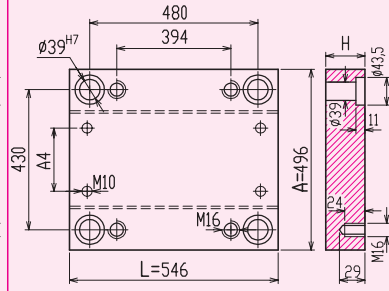
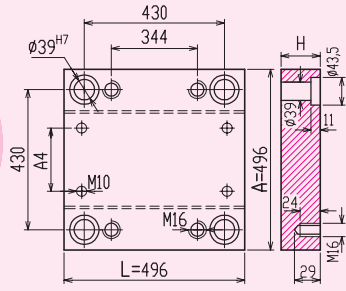

Plakalar / Plates	H	EK4949	EK4954	EK4959									
<b>H1-H2</b> 	37												
	47												
	57												
	67												
	77												
	87												
	97												
<b>H6</b> 	37												
	47												
	57												
	67												
	77												
<b>H4</b> 	37												
	47												
	57												
	67												
<b>H3</b> 	77												
	87												
	97												
	107												
	117												
<b>H5-H9</b> 	37												
	47												
	57												
<b>H7</b> 	22												
	27												
	<table border="1"> <tr><td>A5</td><td>A3</td><td>A4</td></tr> <tr><td>57</td><td>376</td><td>352</td></tr> <tr><td>77</td><td>336</td><td>312</td></tr> </table>				A5	A3	A4	57	376	352	77	336	312
A5	A3	A4											
57	376	352											
77	336	312											
<b>H8</b> 	27												
	<table border="1"> <tr><td>A5</td><td>A3</td><td>A4</td></tr> <tr><td>57</td><td>376</td><td>352</td></tr> <tr><td>77</td><td>336</td><td>312</td></tr> </table>				A5	A3	A4	57	376	352	77	336	312
	A5				A3	A4							
57	376	352											
77	336	312											
<table border="1"> <tr><td>A5</td><td>A3</td><td>A4</td></tr> <tr><td>57</td><td>376</td><td>352</td></tr> <tr><td>77</td><td>336</td><td>312</td></tr> </table>	A5	A3	A4	57	376	352	77	336	312				
A5	A3	A4											
57	376	352											
77	336	312											





# Enjeksiyon Kalıp Seti Kuyruklu 496 Serisi Injection Mold Base 496 Series with Locating Pillar

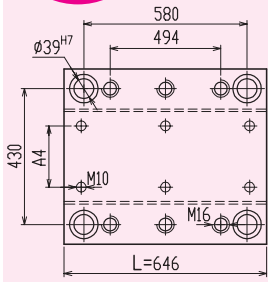

EK4964

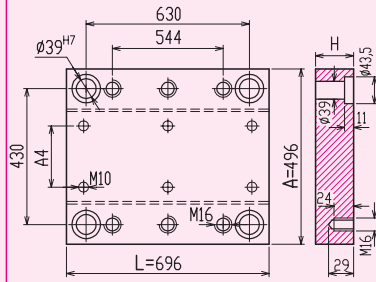

EK4969

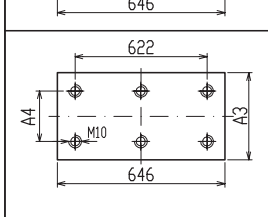
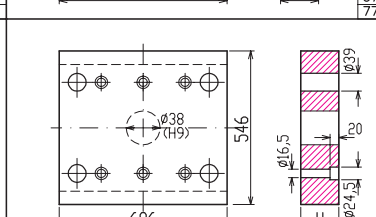
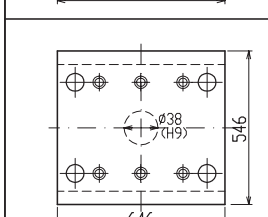
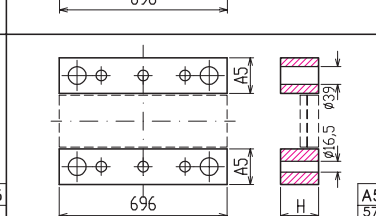
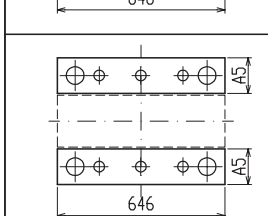
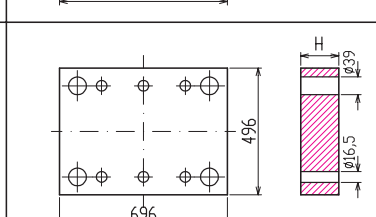
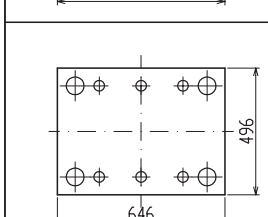
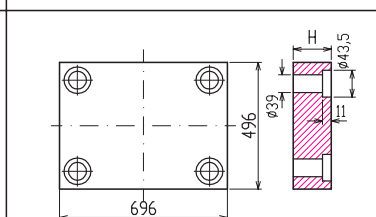
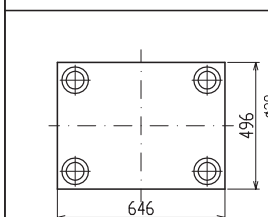
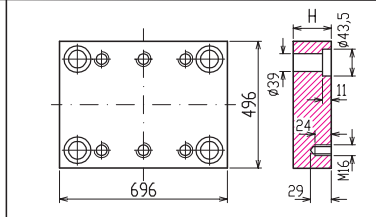
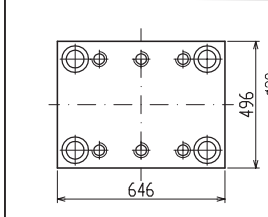

A5	A3	A4
57	376	352
77	336	312

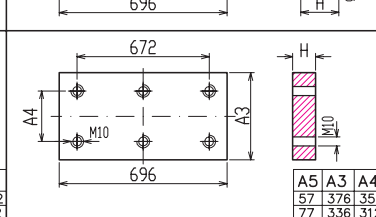

A5	A3	A4
57	376	352
77	336	312

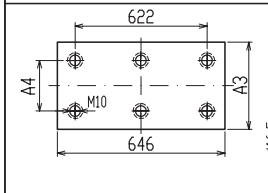

A5	A3	A4
57	376	352
77	336	312

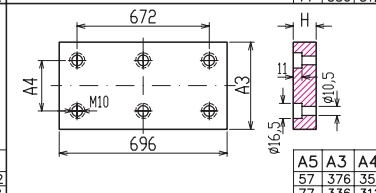

A5	A3	A4
57	376	352
77	336	312

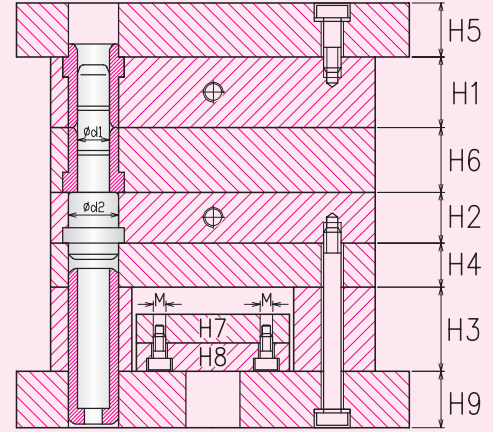

## KOLONLAR / PILLARS

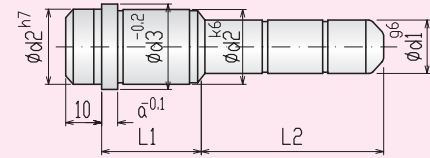

d1	d2	d3	a	L1	L2									
					36	46	56	66	76	86	96	106	116	126
30	39	43	10	36	46	56	66	76	86	96	106	116	126	136

## BURÇLAR / GUIDE BUSHES

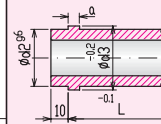

d1	d2	d3	a	L									
				36	46	56	66	76	86	96	106	116	
30	39	43	10	36	46	56	66	76	86	96	106	116	

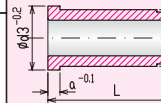

d1	d2	d3	a	L									
				36	46	56	66	76	86	96	106	116	
30	39	43	10	36	46	56	66	76	86	96	106	116	

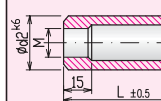

d1	d2	M	L				
			60	80	100	120	140
30	39	M10					

## ÇİVATALAR / SOCKET CAP SCREWS

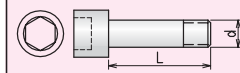

DIN 912 12.9

d	L	20	25	30	35	40	45	50	60	70	80	90	100	110	120	130	140	150	160	180	200	220	240	260	280
M10																									
M16																									

## YAYLI RONDELA / SPRING WASHER

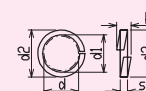

h <sub>max</sub>	d <sub>1</sub>	d <sub>2</sub>	d	s
8.3	16.2	24.4	16	3.5



# Enjeksiyon Kalıp Seti Kuyruklu 546 Serisi

## Injection Mold Base 546 Series with Locating Pillar

ek  
546

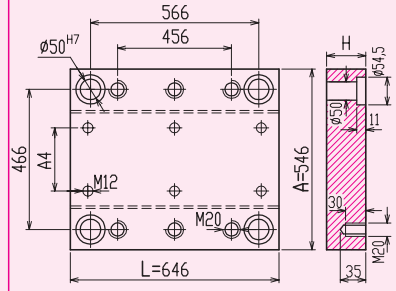
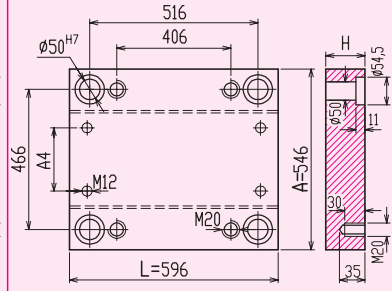
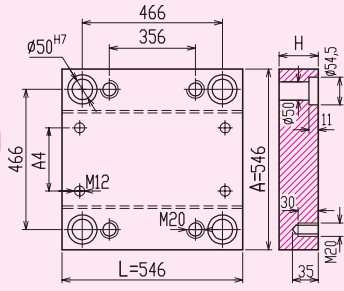

Plakalar / Plates	H	EK5454	EK5459	EK5464																													
<b>H1-H2</b> 	47																																
	57																																
	67																																
	77																																
	87																																
	97																																
	107																																
	117																																
<b>H6</b> 	47																																
	57																																
	67																																
	77																																
	87																																
	97																																
<b>H4</b> 	47																																
	57																																
	67																																
	77																																
<b>H3</b> 	77																																
	87																																
	97																																
	107																																
	117																																
	127																																
<b>H5-H9</b> 	47																																
	57																																
	67																																
<b>H7</b> 	22																																
	27																																
	<table border="1"> <tr><td>A5</td><td>A3</td><td>A4</td></tr> <tr><td>68</td><td>405</td><td>375</td></tr> <tr><td>87</td><td>365</td><td>335</td></tr> </table>				A5	A3	A4	68	405	375	87	365	335	<table border="1"> <tr><td>A5</td><td>A3</td><td>A4</td></tr> <tr><td>68</td><td>405</td><td>375</td></tr> <tr><td>87</td><td>365</td><td>335</td></tr> </table>	A5	A3	A4	68	405	375	87	365	335	<table border="1"> <tr><td>A5</td><td>A3</td><td>A4</td></tr> <tr><td>68</td><td>405</td><td>375</td></tr> <tr><td>87</td><td>365</td><td>335</td></tr> </table>	A5	A3	A4	68	405	375	87	365	335
	A5				A3	A4																											
	68				405	375																											
87	365	335																															
A5	A3	A4																															
68	405	375																															
87	365	335																															
A5	A3	A4																															
68	405	375																															
87	365	335																															
<b>H8</b> 	27																																
	37																																
	<table border="1"> <tr><td>A5</td><td>A3</td><td>A4</td></tr> <tr><td>68</td><td>405</td><td>375</td></tr> <tr><td>87</td><td>365</td><td>335</td></tr> </table>				A5	A3	A4	68	405	375	87	365	335	<table border="1"> <tr><td>A5</td><td>A3</td><td>A4</td></tr> <tr><td>68</td><td>405</td><td>375</td></tr> <tr><td>87</td><td>365</td><td>335</td></tr> </table>	A5	A3	A4	68	405	375	87	365	335	<table border="1"> <tr><td>A5</td><td>A3</td><td>A4</td></tr> <tr><td>68</td><td>405</td><td>375</td></tr> <tr><td>87</td><td>365</td><td>335</td></tr> </table>	A5	A3	A4	68	405	375	87	365	335
A5	A3	A4																															
68	405	375																															
87	365	335																															
A5	A3	A4																															
68	405	375																															
87	365	335																															
A5	A3	A4																															
68	405	375																															
87	365	335																															



# Enjeksiyon Kalıp Seti Kuyruklu 546 Serisi Injection Mold Base 546 Series with Locating Pillar

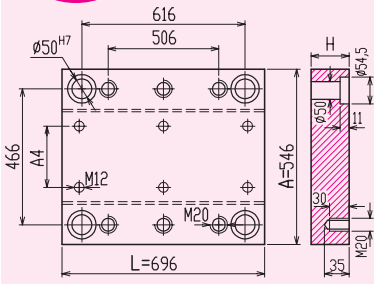

EK5469

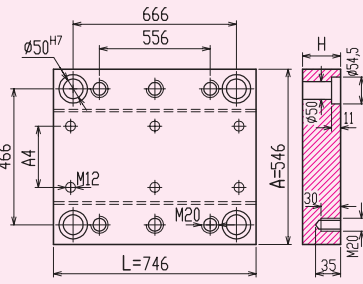

EK5474

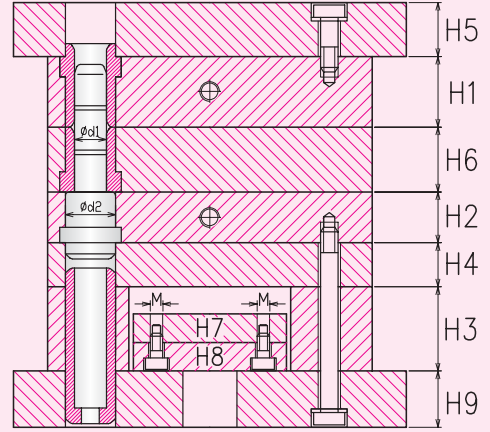
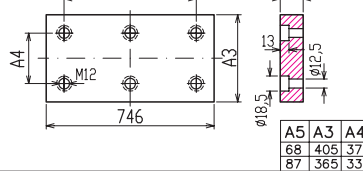
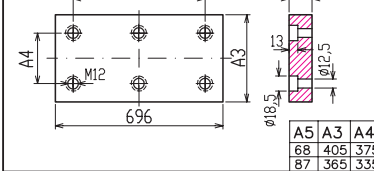
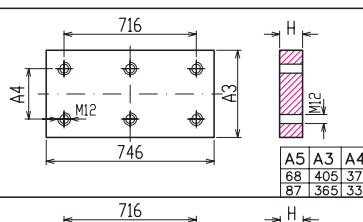
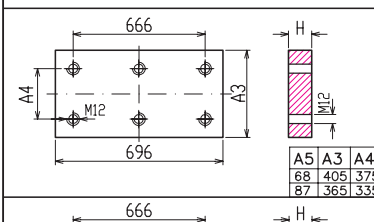
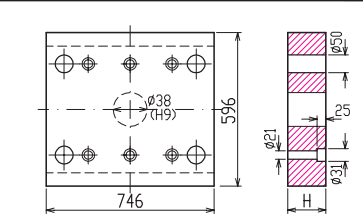
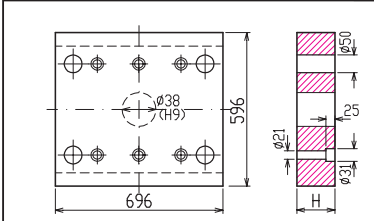
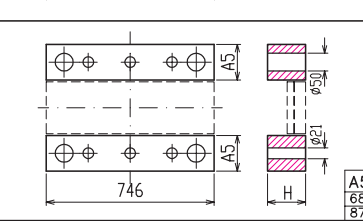
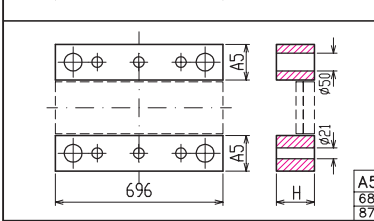
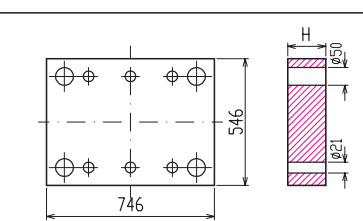
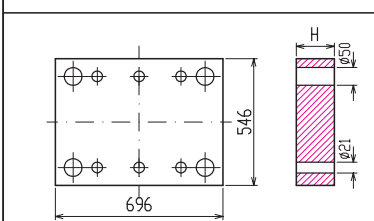
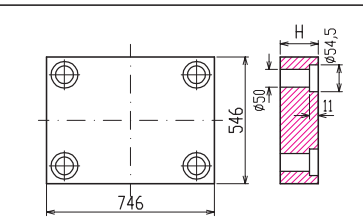
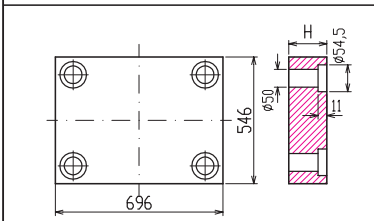
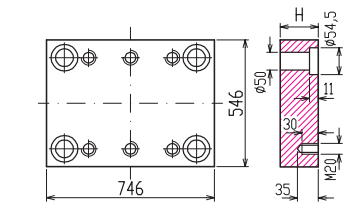
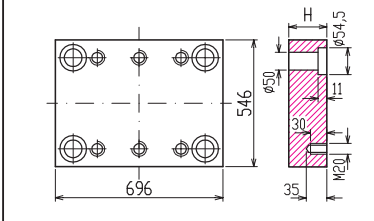

KOLONLAR / PILLARS

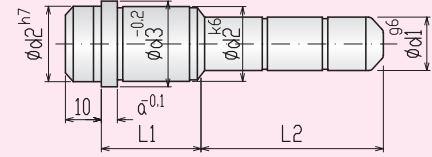

K S K K					L2											
d1	d2	d3	a	L1	46	56	66	76	86	96	106	116	126	136	146	156
40	50	54	10	10	STOKLARDA MEVCUT DEĞİLDİR ÖZEL OLARAK İMAL EDİLİR											

BURÇLAR / GUIDE BUSHES

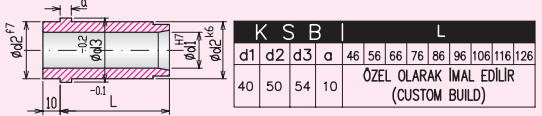

K S B					L								
d1	d2	d3	a	L	46	56	66	76	86	96	106	116	126
40	50	54	10	L	ÖZEL OLARAK İMAL EDİLİR (CUSTOM BUILD)								

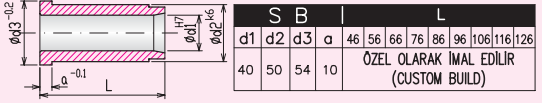

S B					L								
d1	d2	d3	a	L	46	56	66	76	86	96	106	116	126
40	50	54	10	L	ÖZEL OLARAK İMAL EDİLİR (CUSTOM BUILD)								

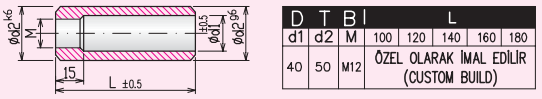

D T B I					L				
d1	d2	M	L	L	100	120	140	160	180
40	50	M12	L ±0.5	L	ÖZEL OLARAK İMAL EDİLİR (CUSTOM BUILD)				

ÇİVATALAR / SOCKET CAP SCREWS

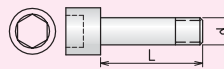

DIN 912 12.9

d	L	25	30	35	40	45	50	60	70	80	90	100	110	120	130	140	150	160	180	200	220	240	260	280	300
M12																									
M20																									

YAYLI RONDELA / SPRING WASHER

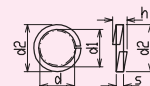

h <sub>max</sub>	d1	d2	d	s
10.6	20.2	30.6	20	4.5



# Enjeksiyon Kalıp Seti Kuyruklu 596 Serisi

## Injection Mold Base 596 Series with Locating Pillar

**ek  
596**

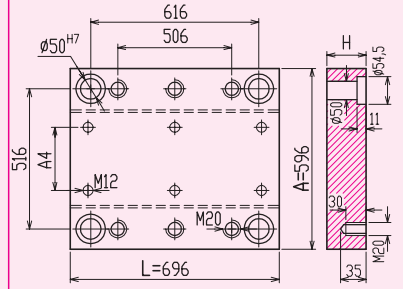
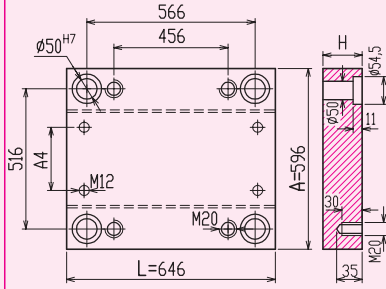
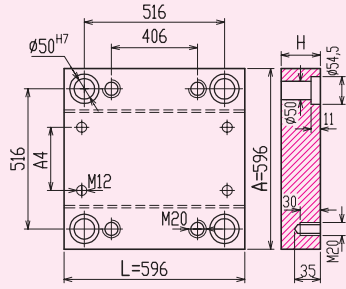

Plakalar / Plates	H	EK5959	EK5964	EK5969																													
<b>H1-H2</b> 	47																																
	57																																
	67																																
	77																																
	87																																
	97																																
	107																																
	117																																
<b>H6</b> 	47																																
	57																																
	67																																
	77																																
	87																																
	97																																
<b>H4</b> 	47																																
	57																																
	67																																
	77																																
<b>H3</b> 	77																																
	87																																
	97																																
	107																																
	117																																
	127																																
<b>H5-H9</b> 	47																																
	57																																
	67																																
<b>H7</b> 	22																																
	27																																
	<table border="1"> <tr><td>A5</td><td>A3</td><td>A4</td></tr> <tr><td>68</td><td>455</td><td>425</td></tr> <tr><td>87</td><td>415</td><td>385</td></tr> </table>				A5	A3	A4	68	455	425	87	415	385	<table border="1"> <tr><td>A5</td><td>A3</td><td>A4</td></tr> <tr><td>68</td><td>455</td><td>425</td></tr> <tr><td>87</td><td>415</td><td>385</td></tr> </table>	A5	A3	A4	68	455	425	87	415	385	<table border="1"> <tr><td>A5</td><td>A3</td><td>A4</td></tr> <tr><td>68</td><td>455</td><td>425</td></tr> <tr><td>87</td><td>415</td><td>385</td></tr> </table>	A5	A3	A4	68	455	425	87	415	385
	A5				A3	A4																											
	68				455	425																											
87	415	385																															
A5	A3	A4																															
68	455	425																															
87	415	385																															
A5	A3	A4																															
68	455	425																															
87	415	385																															
<table border="1"> <tr><td>A5</td><td>A3</td><td>A4</td></tr> <tr><td>68</td><td>455</td><td>425</td></tr> <tr><td>87</td><td>415</td><td>385</td></tr> </table>	A5	A3	A4	68	455	425	87	415	385	<table border="1"> <tr><td>A5</td><td>A3</td><td>A4</td></tr> <tr><td>68</td><td>455</td><td>425</td></tr> <tr><td>87</td><td>415</td><td>385</td></tr> </table>	A5	A3	A4	68	455	425	87	415	385	<table border="1"> <tr><td>A5</td><td>A3</td><td>A4</td></tr> <tr><td>68</td><td>455</td><td>425</td></tr> <tr><td>87</td><td>415</td><td>385</td></tr> </table>	A5	A3	A4	68	455	425	87	415	385				
A5	A3	A4																															
68	455	425																															
87	415	385																															
A5	A3	A4																															
68	455	425																															
87	415	385																															
A5	A3	A4																															
68	455	425																															
87	415	385																															
<table border="1"> <tr><td>A5</td><td>A3</td><td>A4</td></tr> <tr><td>68</td><td>455</td><td>425</td></tr> <tr><td>87</td><td>415</td><td>385</td></tr> </table>	A5	A3	A4	68	455	425	87	415	385	<table border="1"> <tr><td>A5</td><td>A3</td><td>A4</td></tr> <tr><td>68</td><td>455</td><td>425</td></tr> <tr><td>87</td><td>415</td><td>385</td></tr> </table>	A5	A3	A4	68	455	425	87	415	385	<table border="1"> <tr><td>A5</td><td>A3</td><td>A4</td></tr> <tr><td>68</td><td>455</td><td>425</td></tr> <tr><td>87</td><td>415</td><td>385</td></tr> </table>	A5	A3	A4	68	455	425	87	415	385				
A5	A3	A4																															
68	455	425																															
87	415	385																															
A5	A3	A4																															
68	455	425																															
87	415	385																															
A5	A3	A4																															
68	455	425																															
87	415	385																															
<table border="1"> <tr><td>A5</td><td>A3</td><td>A4</td></tr> <tr><td>68</td><td>455</td><td>425</td></tr> <tr><td>87</td><td>415</td><td>385</td></tr> </table>	A5	A3	A4	68	455	425	87	415	385	<table border="1"> <tr><td>A5</td><td>A3</td><td>A4</td></tr> <tr><td>68</td><td>455</td><td>425</td></tr> <tr><td>87</td><td>415</td><td>385</td></tr> </table>	A5	A3	A4	68	455	425	87	415	385	<table border="1"> <tr><td>A5</td><td>A3</td><td>A4</td></tr> <tr><td>68</td><td>455</td><td>425</td></tr> <tr><td>87</td><td>415</td><td>385</td></tr> </table>	A5	A3	A4	68	455	425	87	415	385				
A5	A3	A4																															
68	455	425																															
87	415	385																															
A5	A3	A4																															
68	455	425																															
87	415	385																															
A5	A3	A4																															
68	455	425																															
87	415	385																															
<table border="1"> <tr><td>A5</td><td>A3</td><td>A4</td></tr> <tr><td>68</td><td>455</td><td>425</td></tr> <tr><td>87</td><td>415</td><td>385</td></tr> </table>	A5	A3	A4	68	455	425	87	415	385	<table border="1"> <tr><td>A5</td><td>A3</td><td>A4</td></tr> <tr><td>68</td><td>455</td><td>425</td></tr> <tr><td>87</td><td>415</td><td>385</td></tr> </table>	A5	A3	A4	68	455	425	87	415	385	<table border="1"> <tr><td>A5</td><td>A3</td><td>A4</td></tr> <tr><td>68</td><td>455</td><td>425</td></tr> <tr><td>87</td><td>415</td><td>385</td></tr> </table>	A5	A3	A4	68	455	425	87	415	385				
A5	A3	A4																															
68	455	425																															
87	415	385																															
A5	A3	A4																															
68	455	425																															
87	415	385																															
A5	A3	A4																															
68	455	425																															
87	415	385																															



# Enjeksiyon Kalıp Seti Kuyruklu 596 Serisi Injection Mold Base 596 Series with Locating Pillar

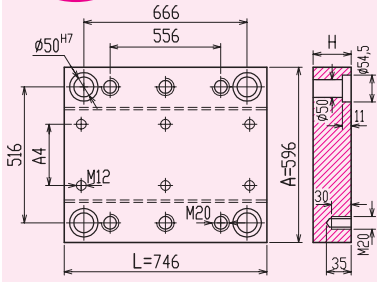

EK5974

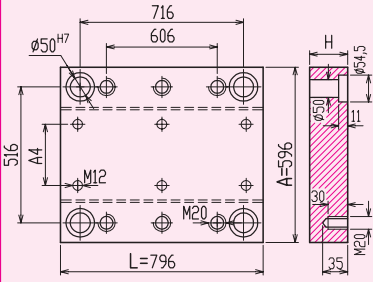

EK5979

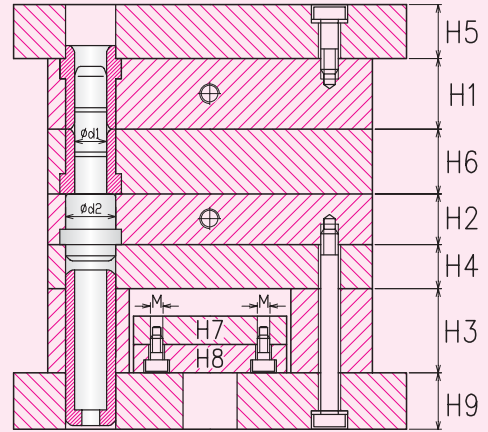

## KOLONLAR / PILLARS

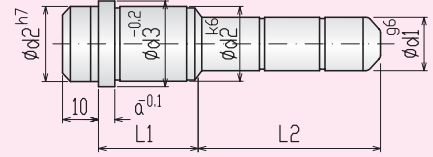

K S K K				L2												
d1	d2	d3	a	L1	46	56	66	76	86	96	106	116	126	136	146	156
40	50	54	10	46	56	66	76	86	96	106	116	126	136	146	156	

STOKLARDA MEVCUT DEĞİLDİR  
ÖZEL OLARAK İMAL EDİLİR

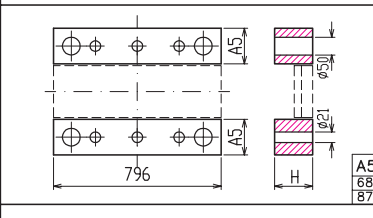
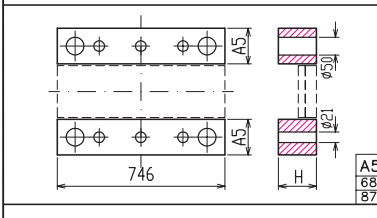
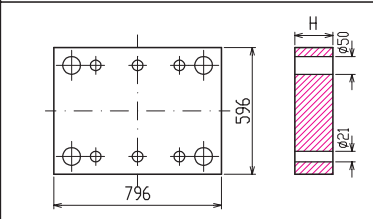
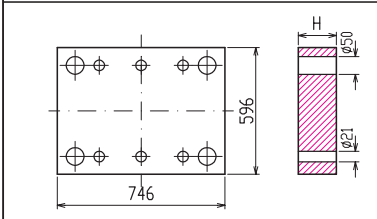
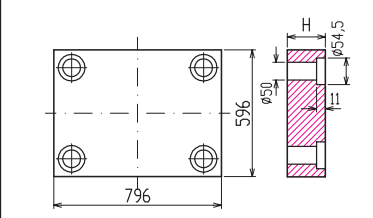
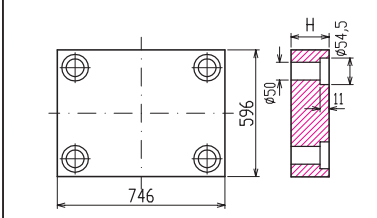
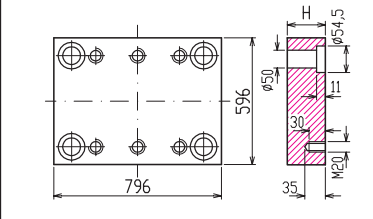
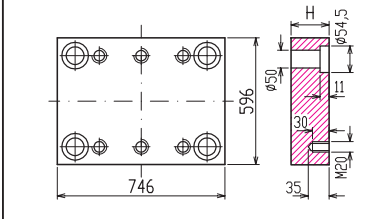

## BURÇLAR / GUIDE BUSHES

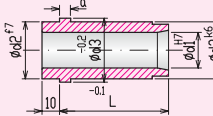

K S B				L											
d1	d2	d3	a	46	56	66	76	86	96	106	116	126	136	146	156
40	50	54	10	ÖZEL OLARAK İMAL EDİLİR (CUSTOM BUILD)											

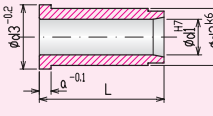

S B				L											
d1	d2	d3	a	46	56	66	76	86	96	106	116	126	136	146	156
40	50	54	10	ÖZEL OLARAK İMAL EDİLİR (CUSTOM BUILD)											

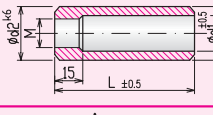

D T B I			L				
d1	d3	M	100	120	140	160	180
40	50	M12	ÖZEL OLARAK İMAL EDİLİR (CUSTOM BUILD)				

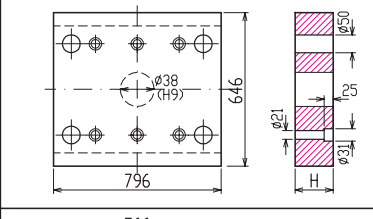
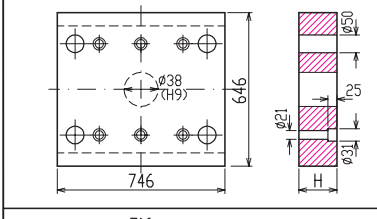

## ÇİVATALAR / SOCKET CAP SCREWS

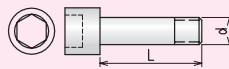

DIN 912 12.9

d	25	30	35	40	45	50	60	70	80	90	100	110	120	130	140	150	160	180	200	220	240	260	300	
M12																								
M20																								

## YAYLI RONDELA / SPRING WASHER

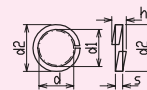

$h_{max}$	d1	d2	d	s
10.6	20.2	30.6	20	4.5

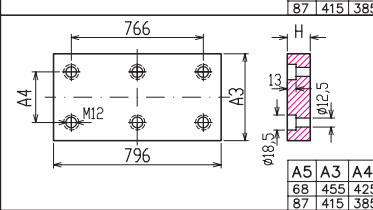
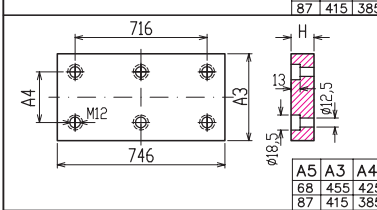



# Enjeksiyon Kalıp Seti Kuyruklu 646 Serisi Injection Mold Base 646 Series with Locating Pillar

ek  
646

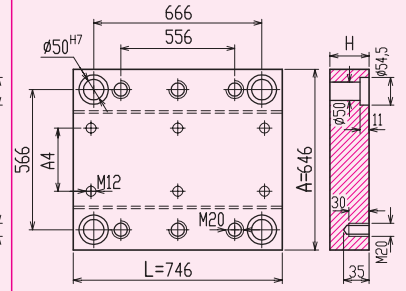
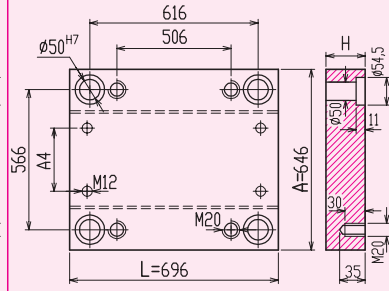
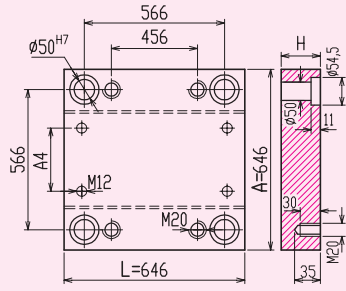

Plakalar / Plates	H	EK6464	EK6469	EK6474																													
<b>H1-H2</b> 	47																																
	57																																
	67																																
	77																																
	87																																
	97																																
	107																																
	117																																
<b>H6</b> 	47																																
	57																																
	67																																
	77																																
	87																																
	97																																
<b>H4</b> 	47																																
	57																																
	67																																
	77																																
<b>H3</b> 	77																																
	87																																
	97																																
	107																																
	117																																
	127																																
<b>H5-H9</b> 	47																																
	57																																
	67																																
<b>H7</b> 	22																																
	27																																
	<table border="1"> <tr><td>A5</td><td>A3</td><td>A4</td></tr> <tr><td>68</td><td>505</td><td>475</td></tr> <tr><td>87</td><td>465</td><td>435</td></tr> </table>				A5	A3	A4	68	505	475	87	465	435	<table border="1"> <tr><td>A5</td><td>A3</td><td>A4</td></tr> <tr><td>68</td><td>505</td><td>475</td></tr> <tr><td>87</td><td>465</td><td>435</td></tr> </table>	A5	A3	A4	68	505	475	87	465	435	<table border="1"> <tr><td>A5</td><td>A3</td><td>A4</td></tr> <tr><td>68</td><td>505</td><td>475</td></tr> <tr><td>87</td><td>465</td><td>435</td></tr> </table>	A5	A3	A4	68	505	475	87	465	435
	A5				A3	A4																											
	68				505	475																											
87	465	435																															
A5	A3	A4																															
68	505	475																															
87	465	435																															
A5	A3	A4																															
68	505	475																															
87	465	435																															
37																																	
<table border="1"> <tr><td>A5</td><td>A3</td><td>A4</td></tr> <tr><td>68</td><td>505</td><td>475</td></tr> <tr><td>87</td><td>465</td><td>435</td></tr> </table>	A5	A3	A4	68	505	475	87	465	435	<table border="1"> <tr><td>A5</td><td>A3</td><td>A4</td></tr> <tr><td>68</td><td>505</td><td>475</td></tr> <tr><td>87</td><td>465</td><td>435</td></tr> </table>	A5	A3	A4	68	505	475	87	465	435	<table border="1"> <tr><td>A5</td><td>A3</td><td>A4</td></tr> <tr><td>68</td><td>505</td><td>475</td></tr> <tr><td>87</td><td>465</td><td>435</td></tr> </table>	A5	A3	A4	68	505	475	87	465	435				
A5	A3	A4																															
68	505	475																															
87	465	435																															
A5	A3	A4																															
68	505	475																															
87	465	435																															
A5	A3	A4																															
68	505	475																															
87	465	435																															



# Enjeksiyon Kalıp Seti Kuyruklu 646 Serisi Injection Mold Base 646 Series with Locating Pillar

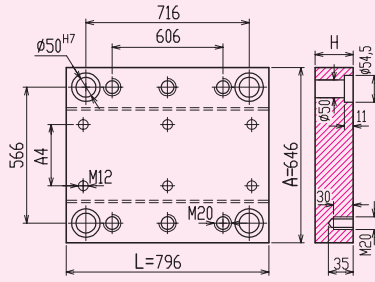

EK6479

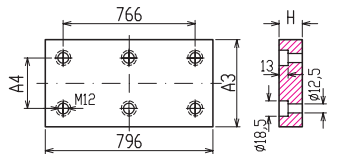
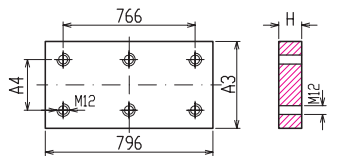
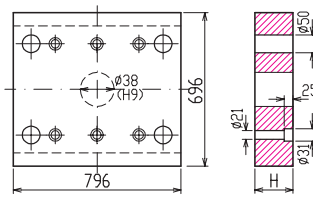
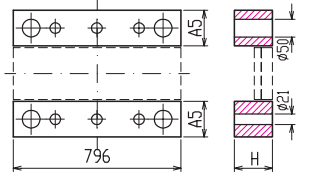
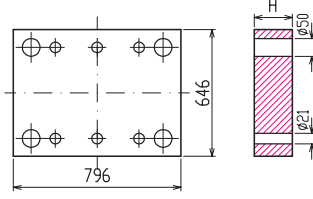
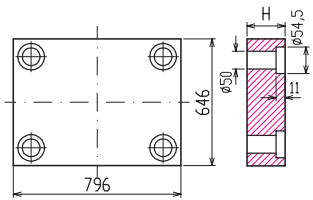
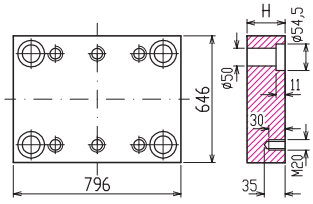

A5	A3	A4
68	505	475
87	465	435

A5	A3	A4
68	505	475
87	465	435

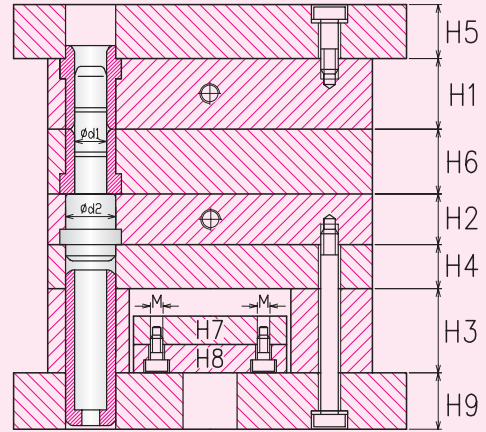

KOLONLAR / PILLARS

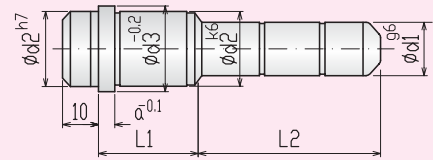

K S K K					L2											
d1	d2	d3	a	L1	46	56	66	76	86	96	106	116	126	136	146	156
40	50	54	10		46	56	66	76	86	96	106	116	126			

STOKLARDA MEVCUT DEĞİLDİR  
ÖZEL OLARAK İMAL EDİLİR

BURÇLAR / GUIDE BUSHES

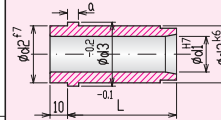

K S B					L										
d1	d2	d3	a	L	46	56	66	76	86	96	106	116	126		
40	50	54	10		ÖZEL OLARAK İMAL EDİLİR (CUSTOM BUILD)										

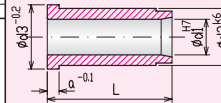

S B					L										
d1	d2	d3	a	L	46	56	66	76	86	96	106	116	126		
40	50	54	10		ÖZEL OLARAK İMAL EDİLİR (CUSTOM BUILD)										

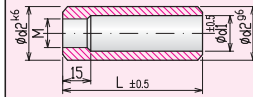

D T B I				L				
d1	d2	M	L	100	120	140	160	180
40	50	M12		ÖZEL OLARAK İMAL EDİLİR (CUSTOM BUILD)				

ÇİVATALAR / SOCKET CAP SCREWS

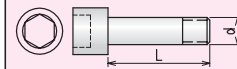

DIN 912 12.9

d	25	30	35	40	45	50	60	70	80	90	100	110	120	130	140	150	160	180	200	220	240	260	280	300	
M12																									
M20																									

YAYLI RONDELA / SPRING WASHER

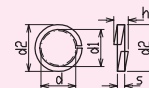

h <sub>max</sub>	d1	d2	d	s
10.6	20.2	30.6	20	4.5





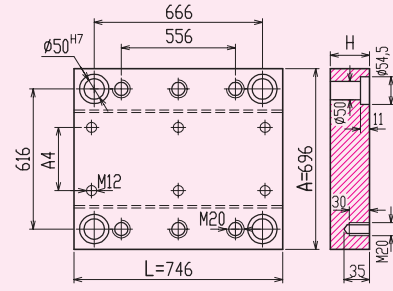
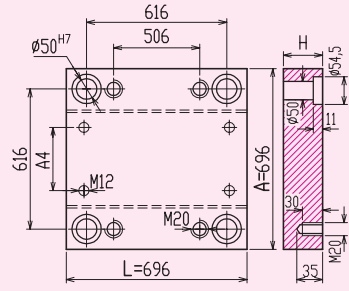

# Enjeksiyon Kalıp Seti Kuyruklu 696 Serisi

## Injection Mold Base 696 Series with Locating Pillar

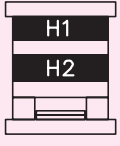
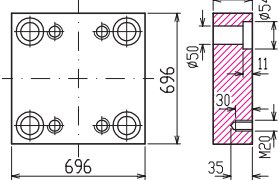
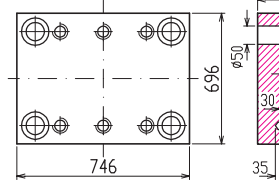
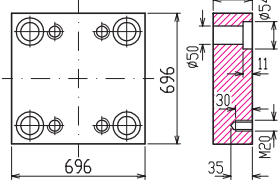
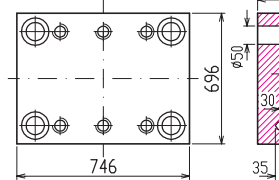
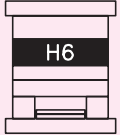
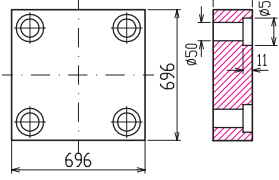
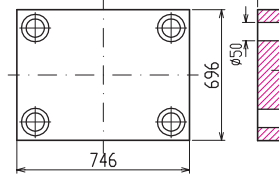
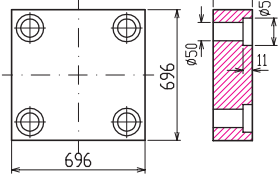
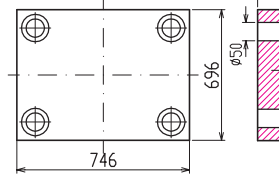
**ek**  
**696**

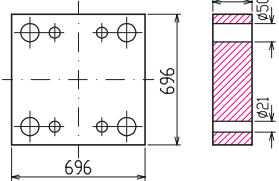
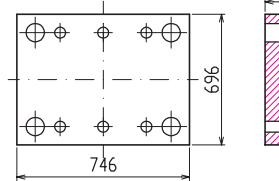
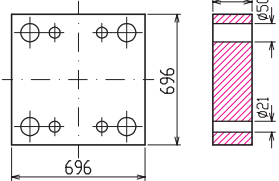
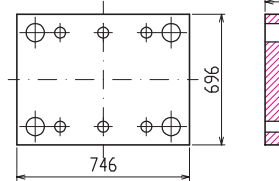
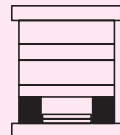
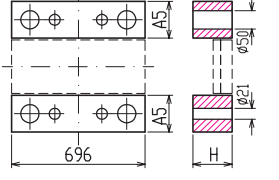
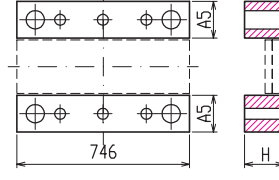
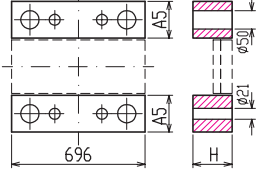
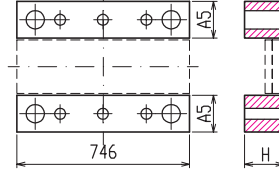

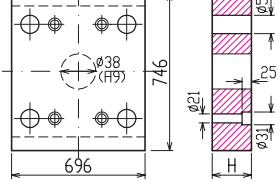
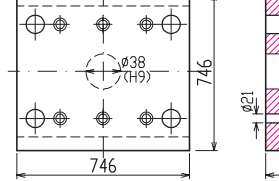
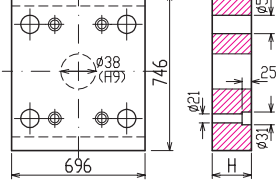
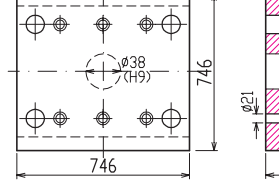
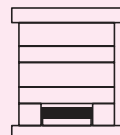
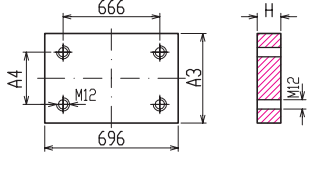
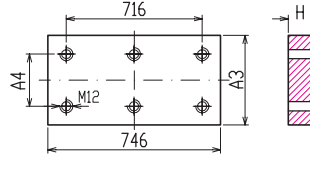
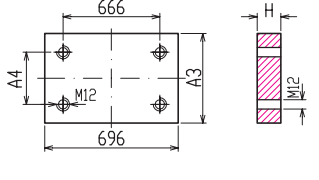
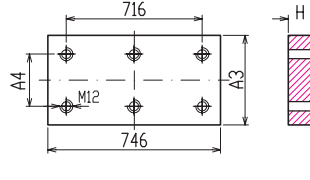
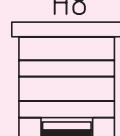
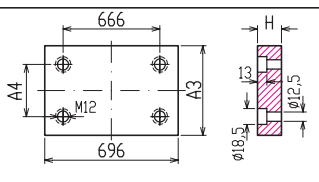
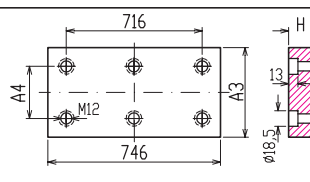
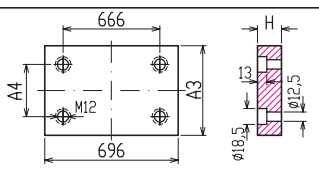
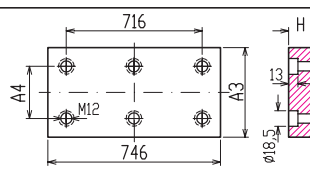
Plakalar / Plates		EK6969		EK6974																			
 H1-H2	47																						
	57																						
	67																						
	77																						
	87																						
	97																						
	107																						
	117																						
 H6	47																						
	57																						
	67																						
	77																						
	87																						
	97																						
 H4	47																						
	57																						
	67																						
	77																						
 H3	77																						
	87																						
	97																						
	107																						
	117																						
	127																						
 H5-H9	47																						
	57																						
	67																						
 H7	22																						
	27																						
 H8	27																						
	37																						
				<table border="1"> <tr><td>A5</td><td>A3</td><td>A4</td></tr> <tr><td>68</td><td>555</td><td>525</td></tr> <tr><td>87</td><td>515</td><td>485</td></tr> </table>	A5	A3	A4	68	555	525	87	515	485	<table border="1"> <tr><td>A5</td><td>A3</td><td>A4</td></tr> <tr><td>68</td><td>555</td><td>525</td></tr> <tr><td>87</td><td>515</td><td>485</td></tr> </table>	A5	A3	A4	68	555	525	87	515	485
A5	A3	A4																					
68	555	525																					
87	515	485																					
A5	A3	A4																					
68	555	525																					
87	515	485																					
				<table border="1"> <tr><td>A5</td><td>A3</td><td>A4</td></tr> <tr><td>68</td><td>555</td><td>525</td></tr> <tr><td>87</td><td>515</td><td>485</td></tr> </table>	A5	A3	A4	68	555	525	87	515	485	<table border="1"> <tr><td>A5</td><td>A3</td><td>A4</td></tr> <tr><td>68</td><td>555</td><td>525</td></tr> <tr><td>87</td><td>515</td><td>485</td></tr> </table>	A5	A3	A4	68	555	525	87	515	485
A5	A3	A4																					
68	555	525																					
87	515	485																					
A5	A3	A4																					
68	555	525																					
87	515	485																					





# Enjeksiyon Kalıp Seti Kuyruklu 696 Serisi Injection Mold Base 696 Series with Locating Pillar

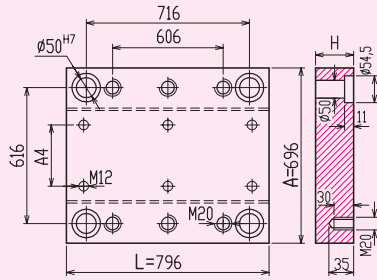

**EK6979**

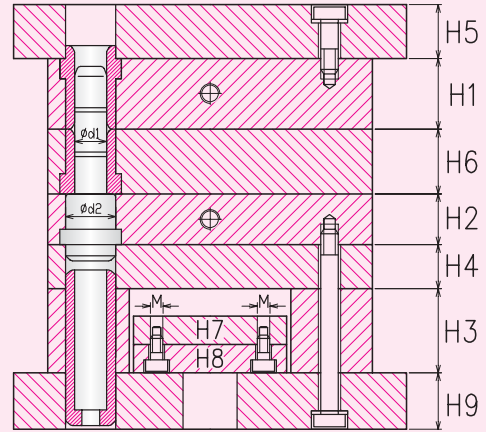
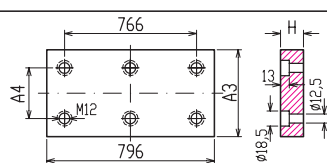
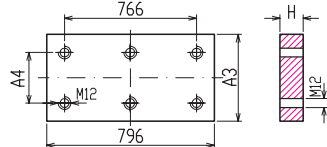
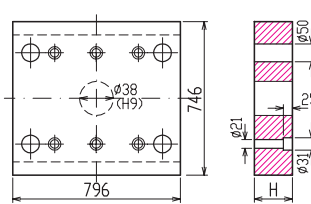
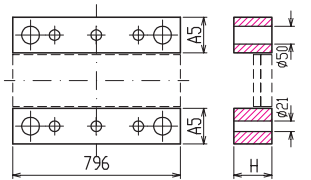
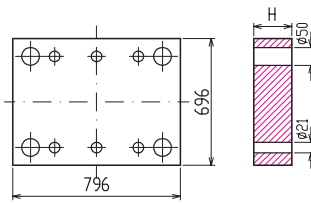
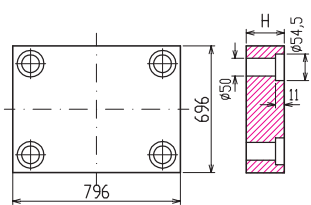
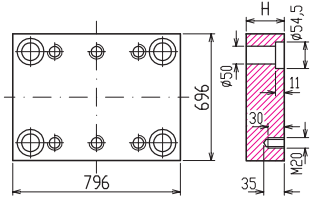

**KOLONLAR / PILLARS**

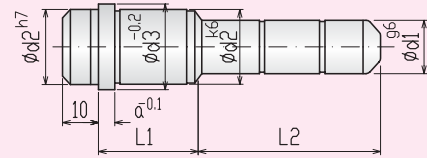

K S K K				L2												
d1	d2	d3	a	L1	46	56	66	76	86	96	106	116	126	136	146	156
40	50	54	10	46	56	66	76	86	96	106	116	126	136	146	156	

STOKLARDA MEVCUT DEĞİLDİR  
ÖZEL OLARAK İMAL EDİLİR

**BURÇLAR / GUIDE BUSHES**

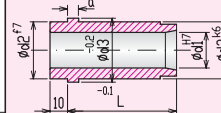

K S B				L											
d1	d2	d3	a	46	56	66	76	86	96	106	116	126			
40	50	54	10	ÖZEL OLARAK İMAL EDİLİR (CUSTOM BUILD)											

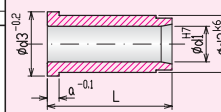

S B				L											
d1	d2	d3	a	46	56	66	76	86	96	106	116	126			
40	50	54	10	ÖZEL OLARAK İMAL EDİLİR (CUSTOM BUILD)											

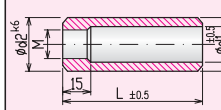

D T B I			L				
d1	d2	M	100	120	140	160	180
40	50	M12	ÖZEL OLARAK İMAL EDİLİR (CUSTOM BUILD)				

**ÇİVATALAR / SOCKET CAP SCREWS**

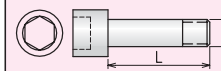

DIN 912 12.9

d	25	30	35	40	45	50	60	70	80	90	100	110	120	130	140	150	160	180	200	220	240	260	300	
M12																								
M20																								

**YAYLI RONDELA / SPRING WASHER**

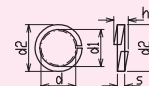

$h_{max}$	d1	d2	d	s
10,6	20,2	30,6	20	4,5

A5	A3	A4
68	555	525
87	515	485

A5	A3	A4
68	555	525
87	515	485

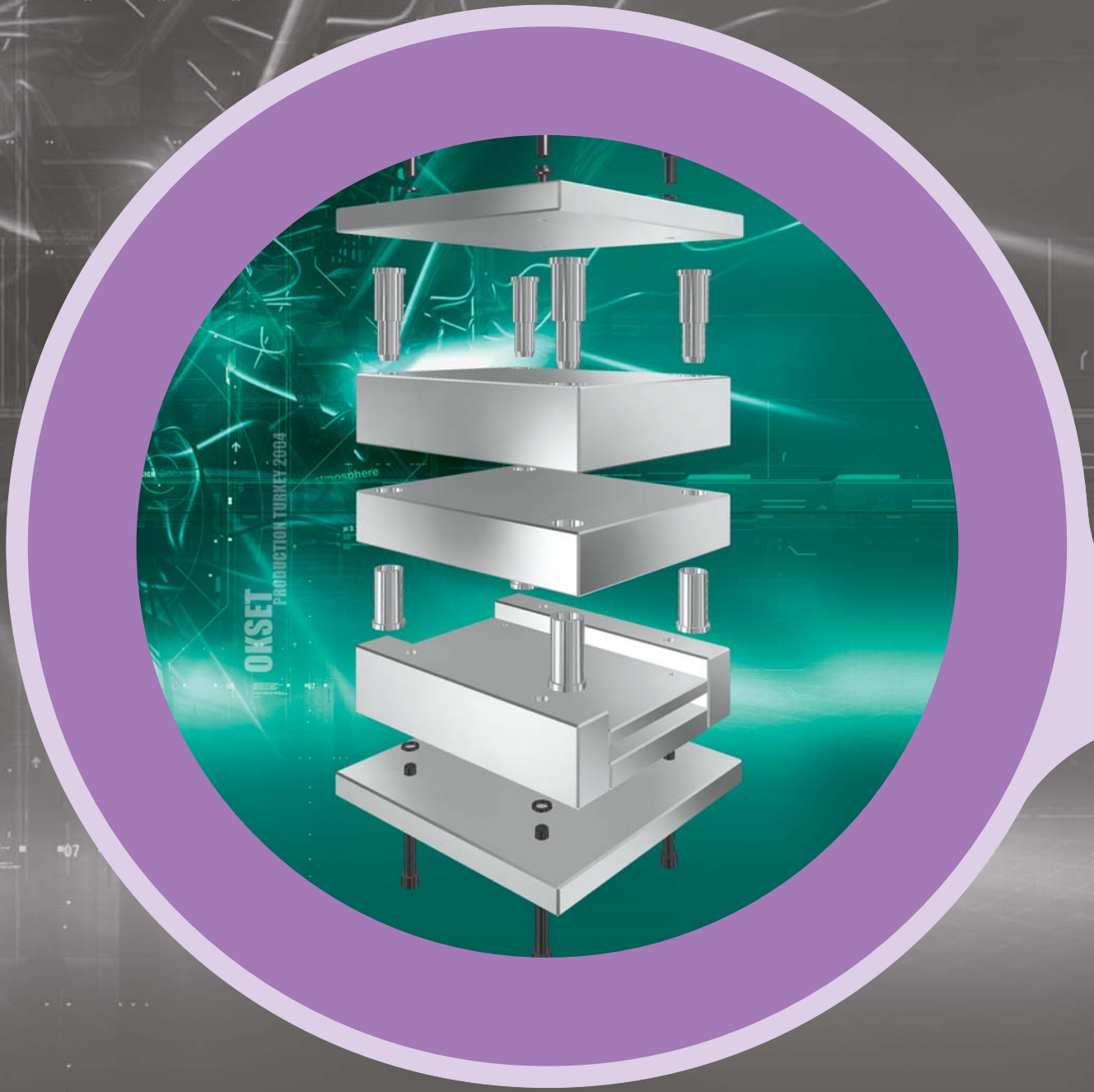

OKSET  
PRODUCTION TURKEY 2004

07

# Ters Enjeksiyon Kalıp Seti

## Reverse Injection Mold Base

te

serisi / series



 **OKSET®**



# Ters Enjeksiyon Kalıp Seti 156 Serisi

## 156 Series of Reverse Injection Mold Base

te  
156

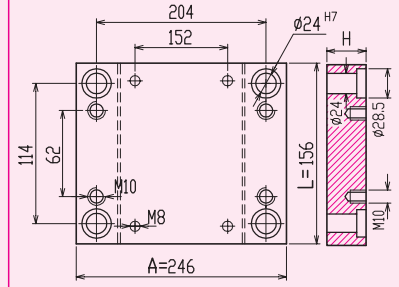
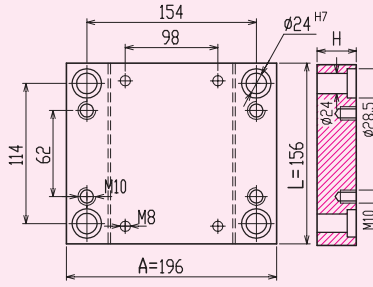
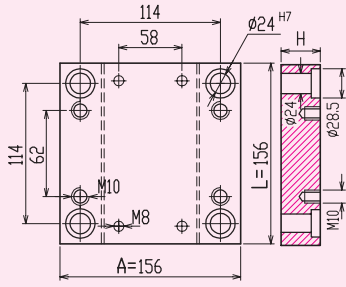

Plakalar / Plates	H	TE1515	TE1915	TE2415
<b>H1-H2</b> 	27			
	37			
	47			
	57			
	67			
	77			
	87			
<b>H6</b> 	27			
	37			
	47			
	57			
	87			
<b>H4</b> 	27			
	37			
	47			
<b>H3</b> 	57			
	67			
	77			
<b>H5-H9</b> 	27			
<b>H7</b> 	14			
	17			
<b>H8</b> 	17			



# Ters Enjeksiyon Kalıp Seti 156 Serisi

## 156 Series of Reverse Injection Mold Base

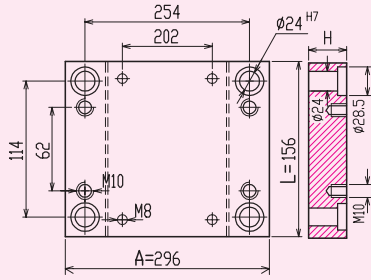

TE2915

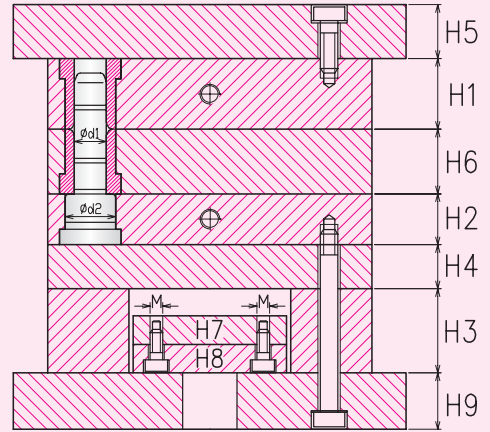
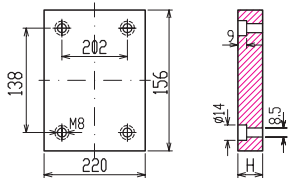
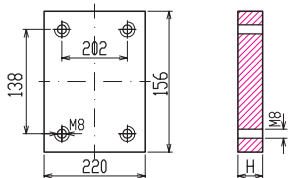
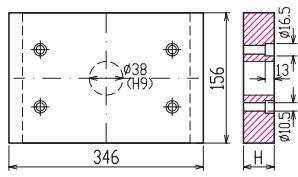
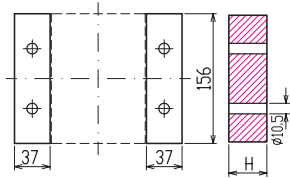
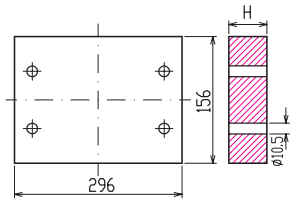
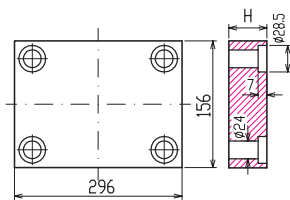
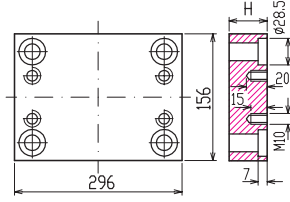

KOLONLAR / PILLARS

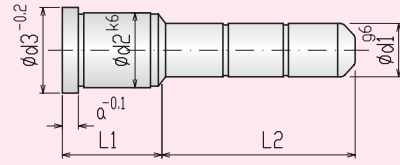

S K K				L2										
d1	d2	d3	a	L1	26	36	46	56	66	76	86	96	106	116
16	24	28	6	26	36	46	56	66	76	86	96	106	116	

BURÇLAR / GUIDE BUSHES

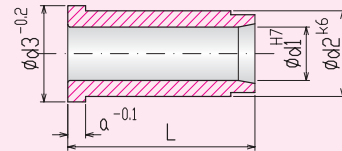

S B				L						
d1	d2	d3	a	26	36	46	56	66	76	86
16	24	28	6							

ÇİVATALAR / SOCKET CAP SCREWS

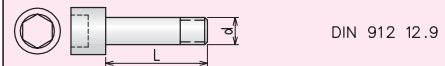

d	L	20	25	30	35	40	45	50	60	70	80	90	100	110	120	130	140	150	160	180	200	220	240	260	280	
M8																										
M10																										

YAYLI RONDELA / SPRING WASHER

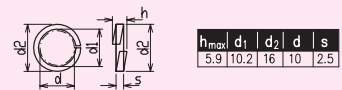

h <sub>max</sub>	d1	d2	d	s
5.9	10.2	16	10	2.5



# Ters Enjeksiyon Kalıp Seti 196 Serisi

## 196 Series of Reverse Injection Mold Base

te  
196

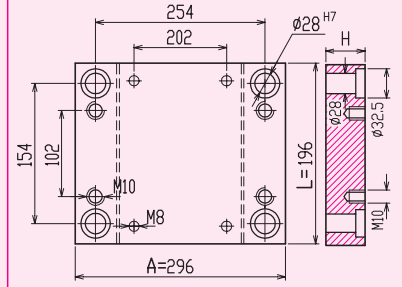
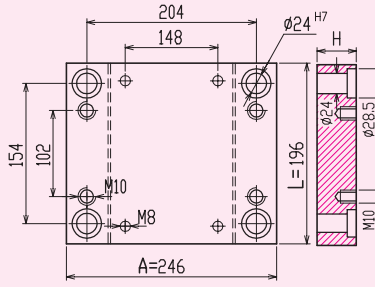
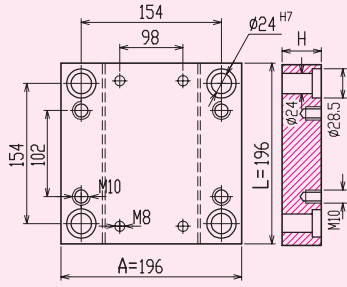

Plakalar / Plates	H	TE1919	TE2419	TE2919
 H1 H2	27			
	37			
	47			
	57			
	67			
	77			
	87			
 H6	27			
	37			
	47			
	57			
	87			
 H4	27			
	37			
	47			
 H3	57			
	67			
	77			
 H5 H9	27			
 H7	14			
	17			
 H8	17			



# Ters Enjeksiyon Kalıp Seti 196 Serisi

## 196 Series of Reverse Injection Mold Base

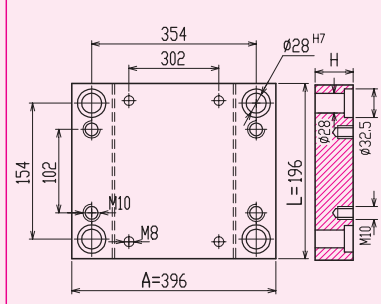
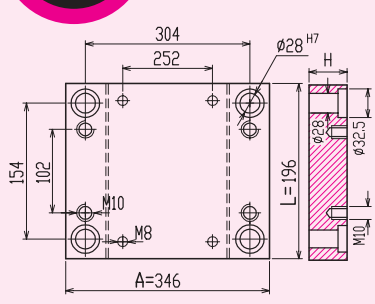

TE3419

TE3919

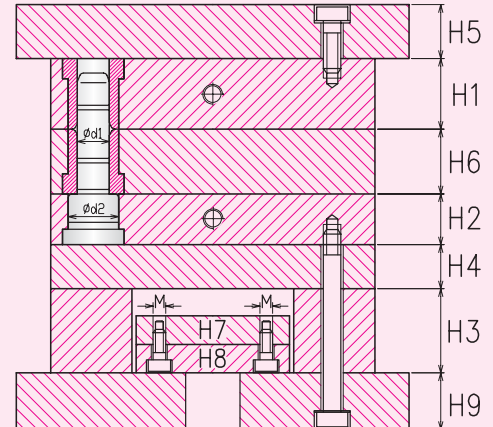
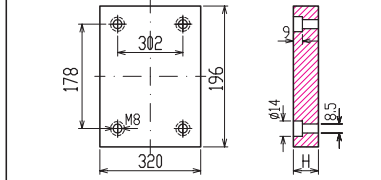
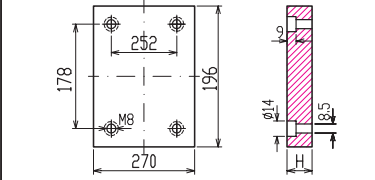
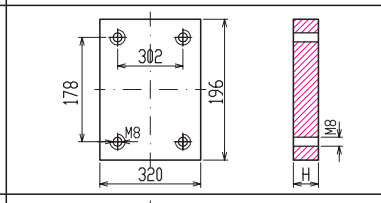
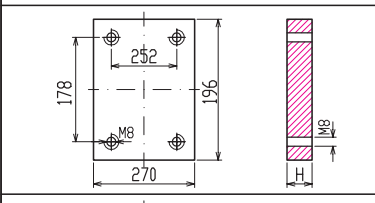
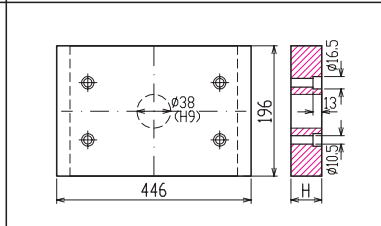
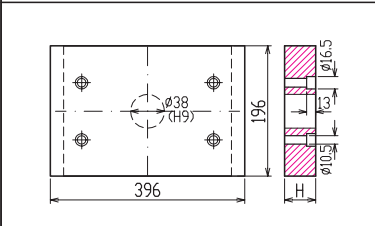
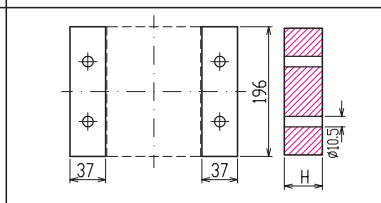
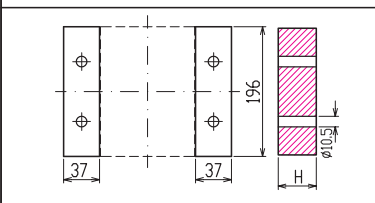
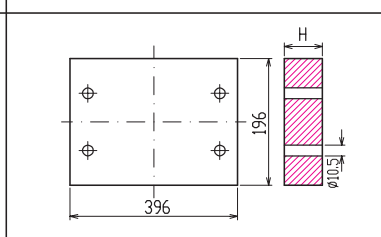
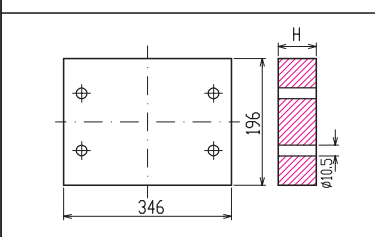
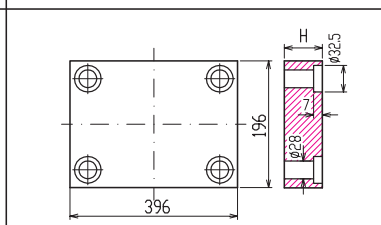
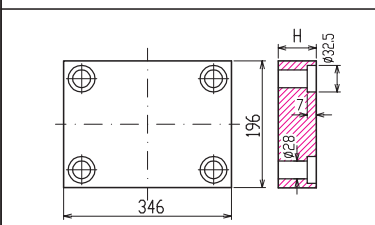
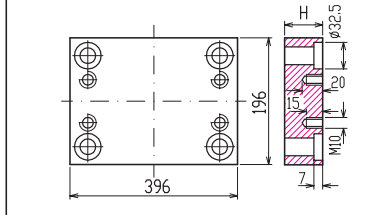
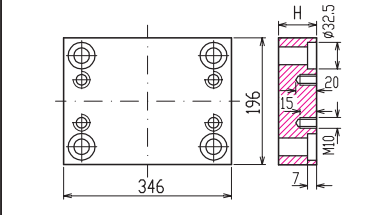

### KOLONLAR / PILLARS

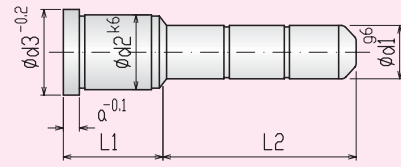

S K K			L2																	
d1	d2	d3	a	L1	26	36	46	56	66	76	86	96	106	116	126	136	146			
16	24	28	6	26																
				36																
				46																
				56																
				66																
				76																
20	28	32	6	26																
				36																
				46																
				56																
				66																
				76																

### BURÇLAR / GUIDE BUSHES

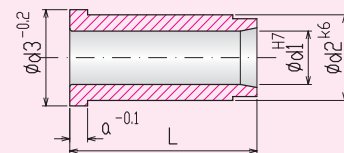

S B				L							
d1	d2	d3	a	26	36	46	56	66	76	86	96
16	24	28	6								
20	28	32	6								

### ÇİVATALAR / SOCKET CAP SCREWS

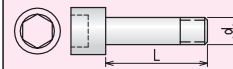

DIN 912 12.9

d	L	20	25	30	35	40	45	50	60	70	80	90	100	110	120	130	140	150	160	180	200	220	240	260	280	
M8																										
M10																										

### YAYLI RONDELA / SPRING WASHER

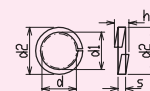

h <sub>max</sub>	d1	d2	d	s
5.9	10.2	16	10	2.5



# Ters Enjeksiyon Kalıp Seti 246 Serisi

## 246 Series of Reverse Injection Mold Base

te  
246

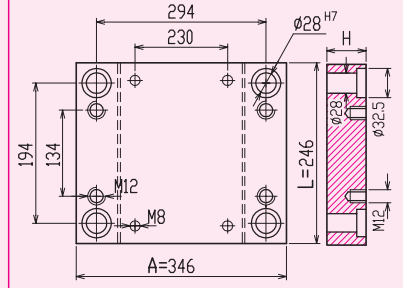
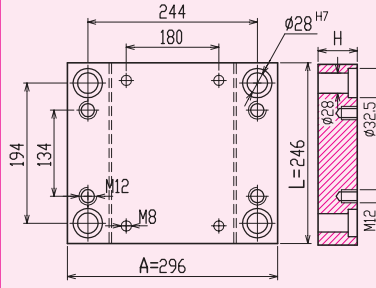
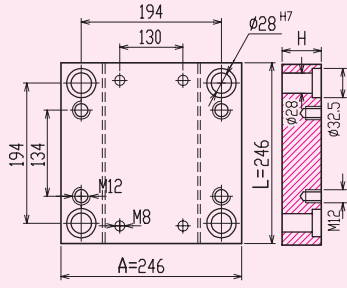

Plakalar / Plates	H	TE2424	TE2924	TE3424
<b>H1-H2</b> 	27			
	37			
	47			
	57			
	67			
	77			
<b>H6</b> 	27			
	37			
	47			
	57			
	67			
	77			
<b>H4</b> 	27			
	37			
	47			
<b>H3</b> 	57			
	67			
	77			
	87			
	97			
<b>H5-H9</b> 	27			
	37			
<b>H7</b> 	14			
	17			
<b>H8</b> 	17			
	17			





# Ters Enjeksiyon Kalıp Seti 246 Serisi

## 246 Series of Reverse Injection Mold Base

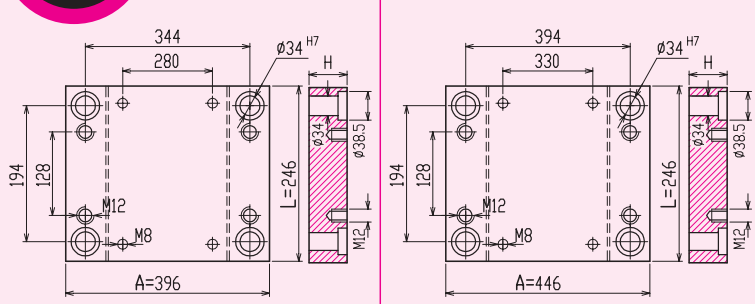

TE3924

TE4424

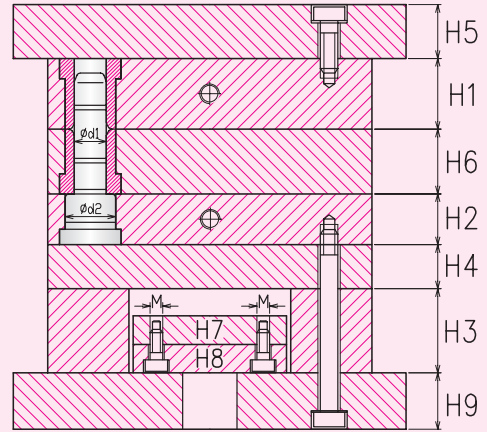
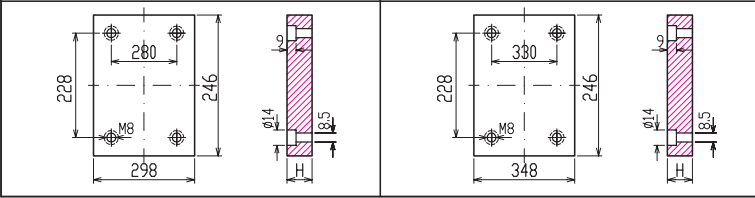
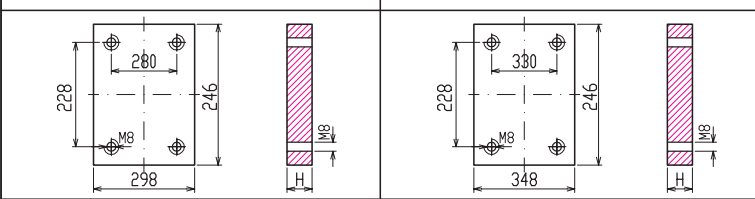
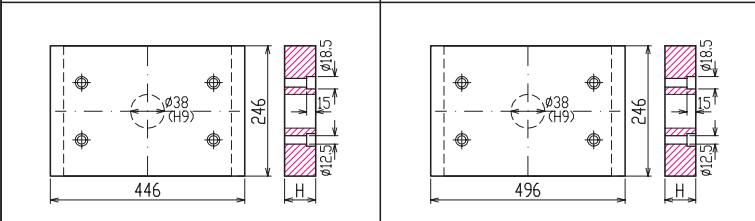
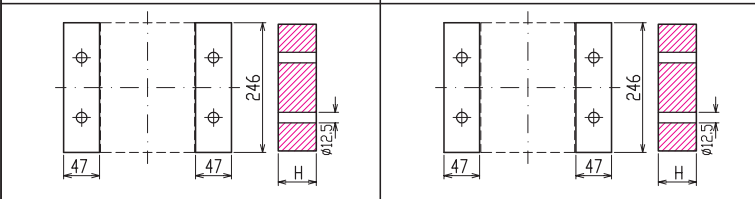
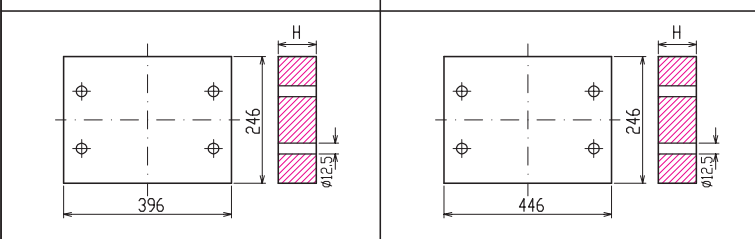
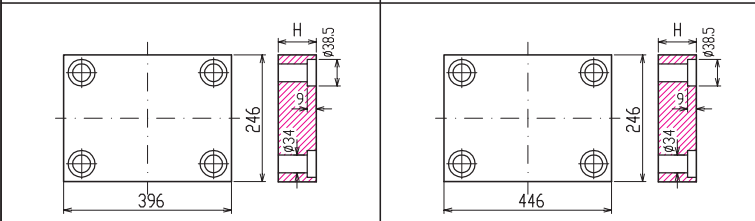
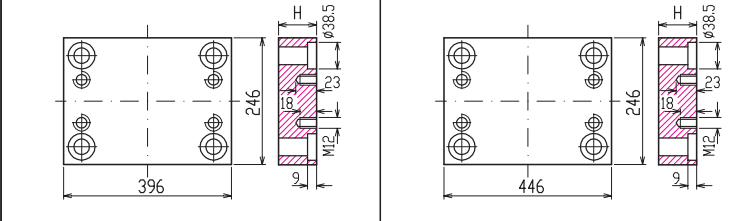

### KOLONLAR / PILLARS

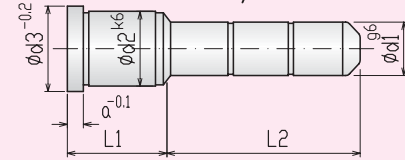

S K K			L2														
d1	d2	d3	a	L1	26	36	46	56	66	76	86	96	106	116	126	136	146
20	28	32	6	26	36	46	56	66	76	86	96	106	116	126	136	146	
				56	66	76	86	96	106	116	126	136	146				
				66	76	86	96	106	116	126	136	146					
				76	86	96	106	116	126	136	146						
				86	96	106	116	126	136	146							
				96	106	116	126	136	146								
				106	116	126	136	146									
				116	126	136	146										
				126	136	146											
				136	146												
25	34	38	8	26	36	46	56	66	76	86	96	106	116	126	136	146	
				56	66	76	86	96	106	116	126	136	146				
				66	76	86	96	106	116	126	136	146					
				76	86	96	106	116	126	136	146						
				86	96	106	116	126	136	146							
				96	106	116	126	136	146								
				106	116	126	136	146									
				116	126	136	146										
				126	136	146											
				136	146												

### BURÇLAR / GUIDE BUSHES

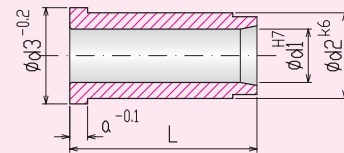

S B			L									
d1	d2	d3	a	26	36	46	56	66	76	86	96	106
20	28	32	6									
25	34	38	8									

### ÇİVATALAR / SOCKET CAP SCREWS

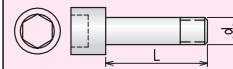

DIN 912 12.9

d	L	20	25	30	35	40	45	50	60	70	80	90	100	110	120	130	140	150	160	180	200	220	240	260	280	
M8																										
M12																										

### YAYLI RONDELA / SPRING WASHER

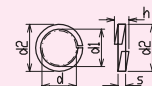

h <sub>max</sub>	d <sub>1</sub>	d <sub>2</sub>	d	s
5.9	12.2	18	12	2.5



# Ters Enjeksiyon Kalıp Seti 296 Serisi

## 296 Series of Reverse Injection Mold Base

te  
296

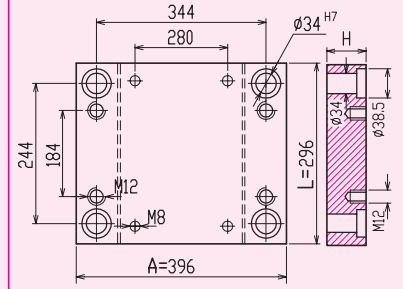
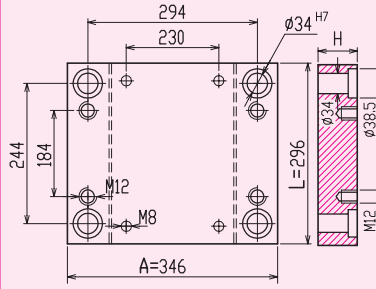
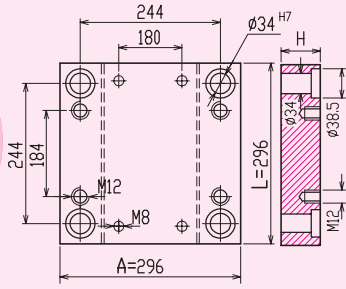

Plakalar / Plates	H	TE2929	TE3429	TE3929
<b>H1-H2</b> 	27			
	37			
	47			
	57			
	67			
	77			
	87			
	97			
<b>H6</b> 	27			
	37			
	47			
	57			
	77			
	87			
<b>H4</b> 	27			
	37			
	47			
	57			
<b>H3</b> 	57			
	67			
	77			
	87			
	97			
<b>H5-H9</b> 	27			
	37			
<b>H7</b> 	17			
	22			
<b>H8</b> 	22			



# Ters Enjeksiyon Kalıp Seti 296 Serisi

## 296 Series of Reverse Injection Mold Base

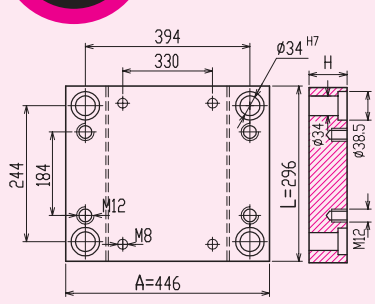

TE4429

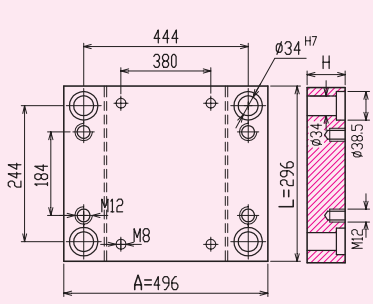

TE4929

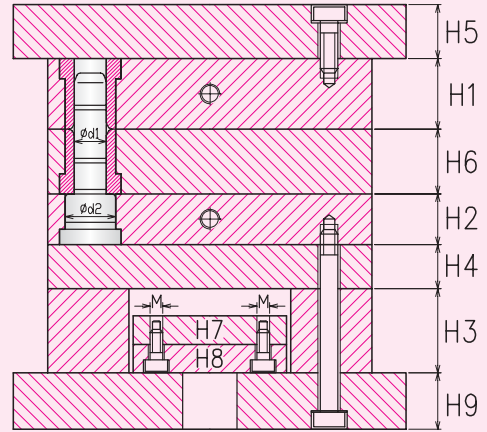
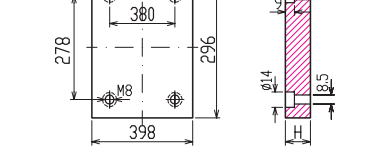
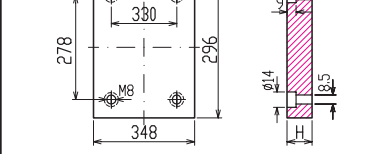
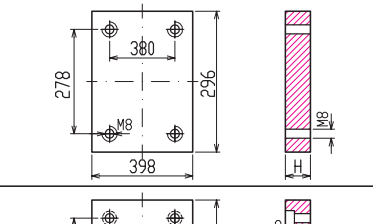
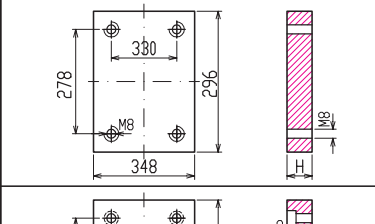
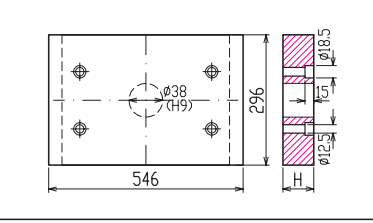
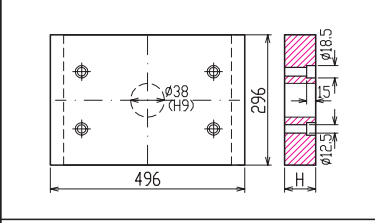
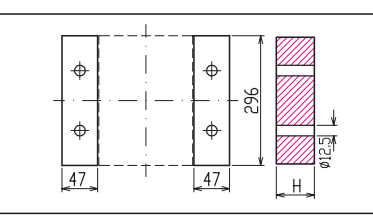
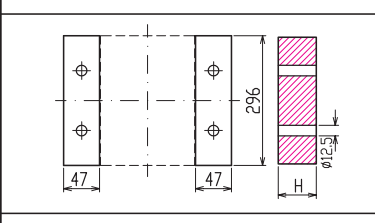
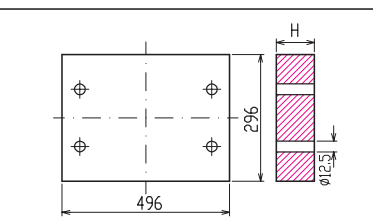
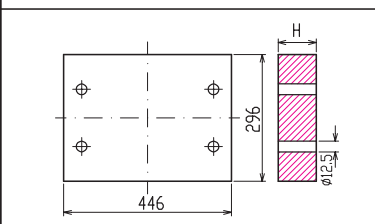
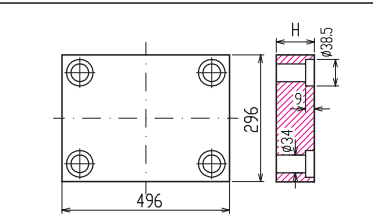
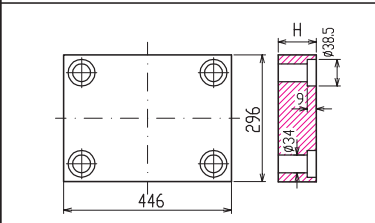
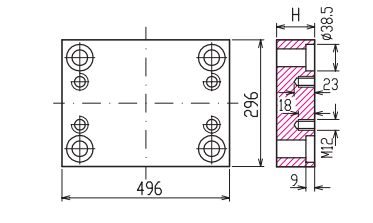
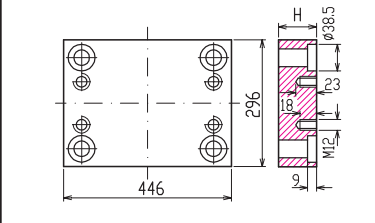

KOLONLAR / PILLARS

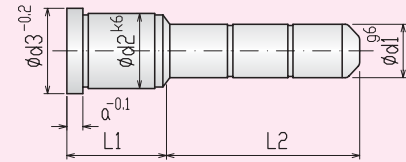

S K K				L2												
d1	d2	d3	a	L1	26	36	46	56	66	76	86	96	106	116	126	136
25	34	38	8	26	36	46	56	66	76	86	96	106	116	126	136	

BURÇLAR / GUIDE BUSHES

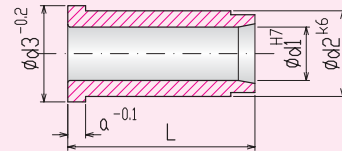

S B				L									
d1	d2	d3	a	26	36	46	56	66	76	86	96	106	
25	34	38	8	26	36	46	56	66	76	86	96	106	

ÇİVATALAR / SOCKET CAP SCREWS

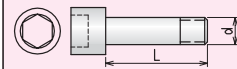

DIN 912 12.9

d	L	20	25	30	35	40	45	50	60	70	80	90	100	110	120	130	140	150	160	180	200	220	240	260	280
M8																									
M12																									

YAYLI RONDELA / SPRING WASHER

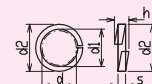

h <sub>max</sub>	d1	d2	d	s
5.9	12.2	18	12	2.5



# Ters Enjeksiyon Kalıp Seti 346 Serisi

## 346 Series of Reverse Injection Mold Base

te  
346

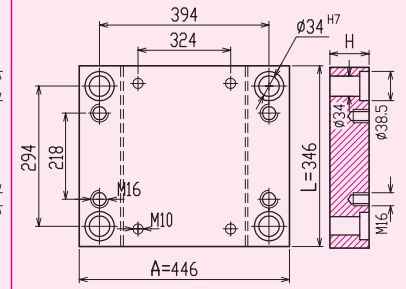
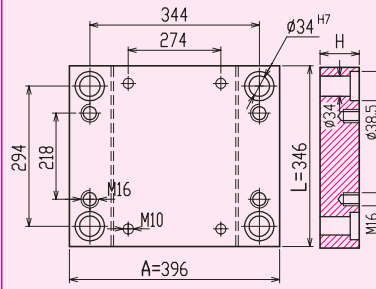
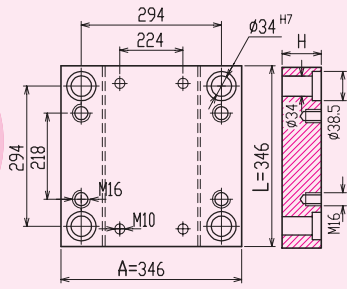

Plakalar / Plates	H	TE3434	TE3934	TE4434
<b>H1-H2</b> 	37			
	47			
	57			
	67			
	77			
	87			
	97			
<b>H6</b> 	27			
	37			
	47			
	57			
	67			
	77			
	87			
<b>H4</b> 	27			
	37			
	47			
	47			
	57			
<b>H3</b> 	57			
	67			
	77			
	87			
	97			
<b>H5-H9</b> 	37			
	47			
<b>H7</b> 	17			
	22			
<b>H8</b> 	22			



# Ters Enjeksiyon Kalıp Seti 346 Serisi

## 346 Series of Reverse Injection Mold Base

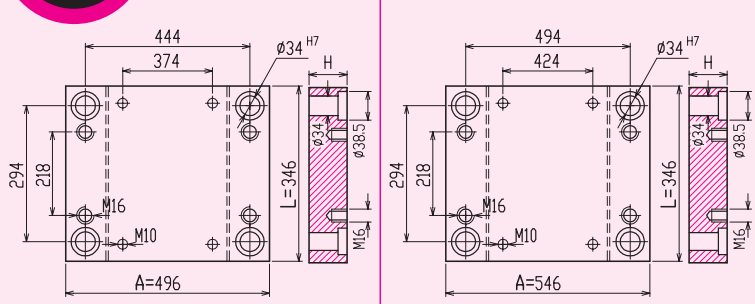

TE4934

TE5434

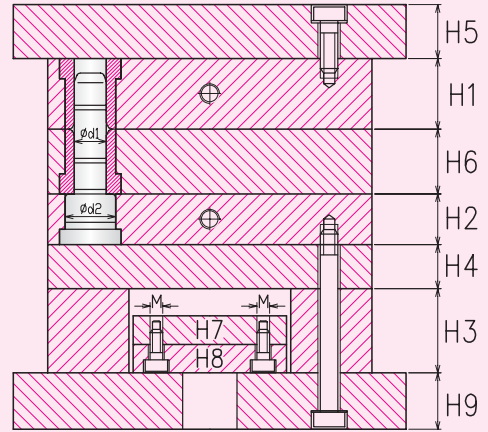
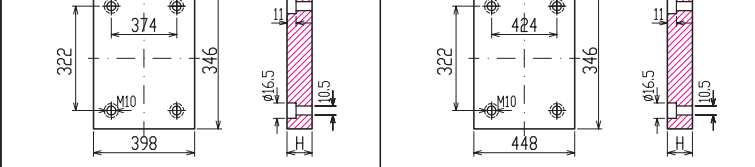
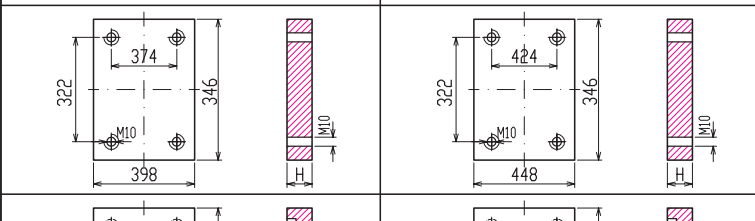
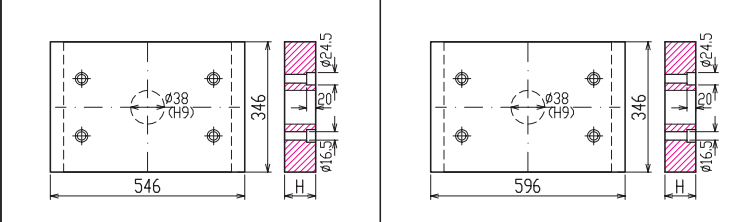
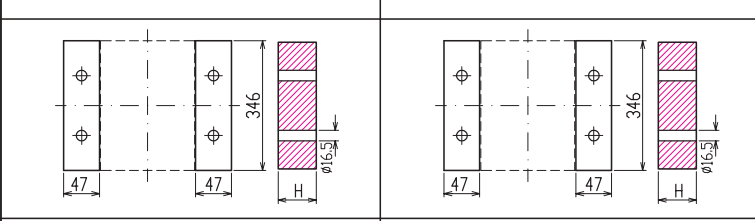
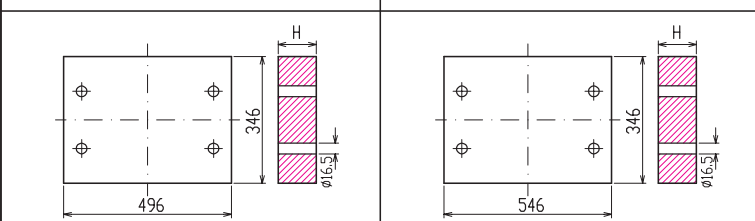
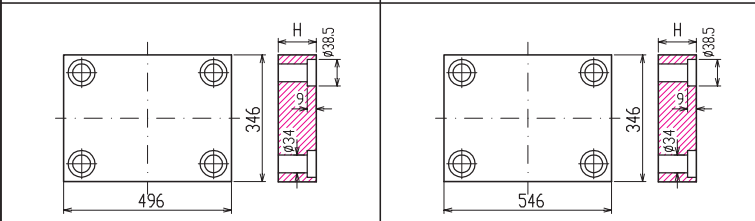
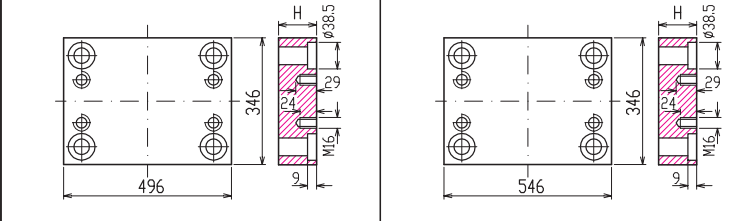

### KOLONLAR / PILLARS

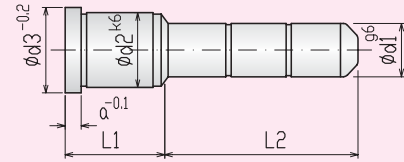

S			L2													
d1	d2	d3	a	L1	26	36	46	56	66	76	86	96	106	116	126	136
25	34	38	8	26	36	46	56	66	76	86	96	106	116	126	136	

### BURÇLAR / GUIDE BUSHES

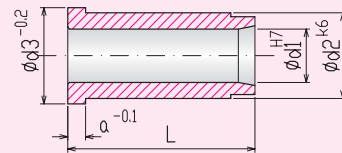

S			L												
d1	d2	d3	a	26	36	46	56	66	76	86	96	106			
25	34	38	8	26	36	46	56	66	76	86	96	106			

### ÇİVATALAR / SOCKET CAP SCREWS

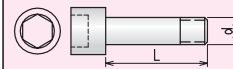

DIN 912 12.9

d	L	20	25	30	35	40	45	50	60	70	80	90	100	110	120	130	140	150	160	180	200	220	240	260	280
M10																									
M16																									

### YAYLI RONDELA / SPRING WASHER

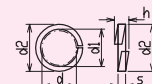

h <sub>max</sub>	d1	d2	d	s
8.3	16.2	24.4	16	3.5



# Ters Enjeksiyon Kalıp Seti 396 Serisi

## 396 Series of Reverse Injection Mold Base

te  
396

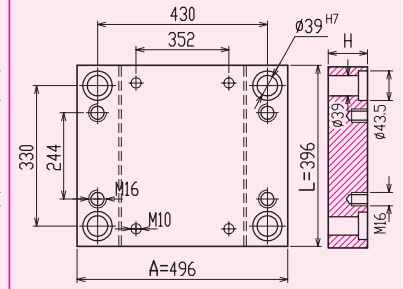
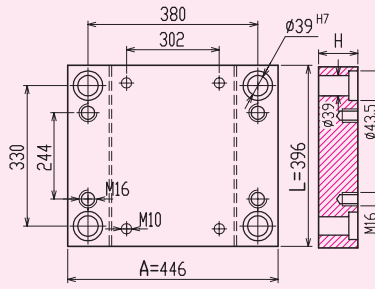
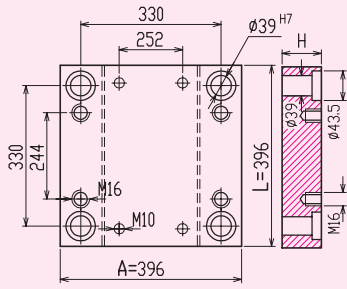

Plakalar / Plates	H	TE3939	TE4439	TE4939
<b>H1-H2</b> 	37			
	47			
	57			
	67			
	77			
	87			
	97			
	107			
<b>H6</b> 	37			
	47			
	57			
	67			
	77			
	87			
<b>H4</b> 	27			
	37			
	47			
	57			
<b>H3</b> 	77			
	87			
	97			
	107			
	117			
<b>H5-H9</b> 	37			
	47			
	57			
<b>H7</b> 	22			
	27			
<b>H8</b> 	27			



# Ters Enjeksiyon Kalıp Seti 396 Serisi

## 396 Series of Reverse Injection Mold Base

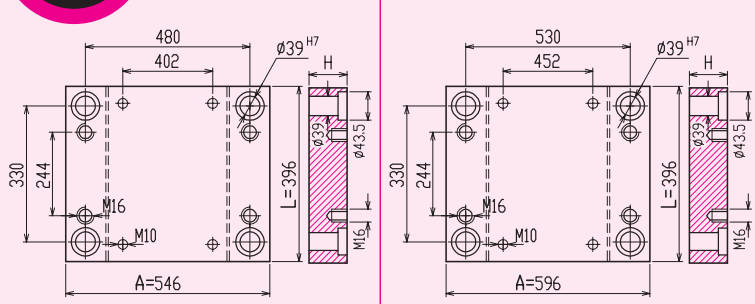

TE5439

TE5939

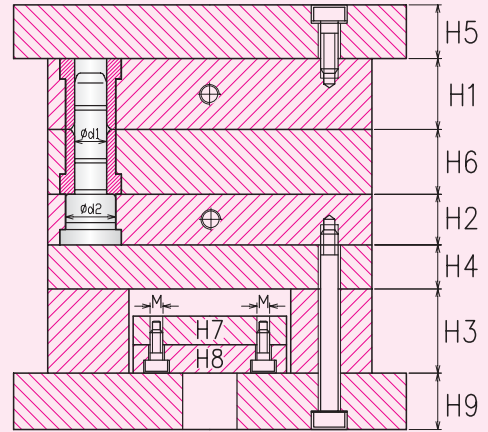
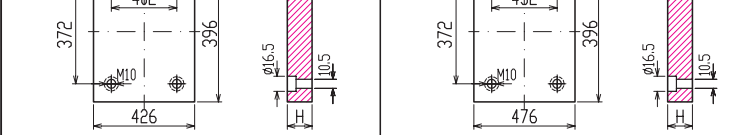
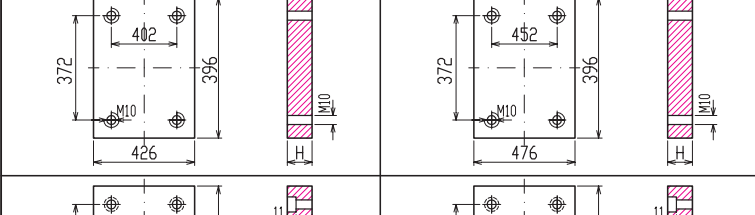
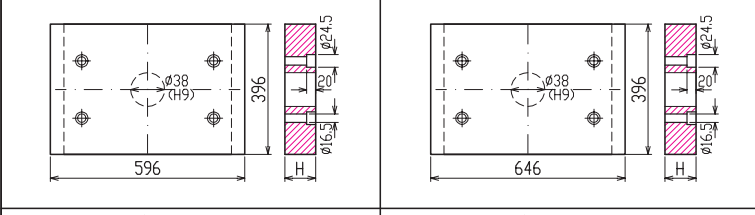
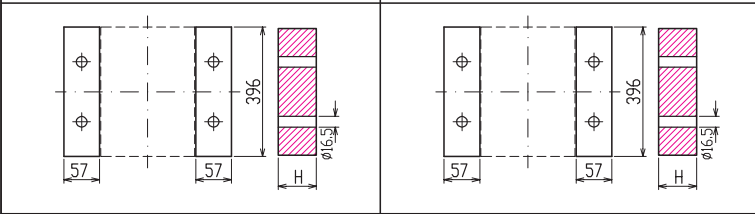
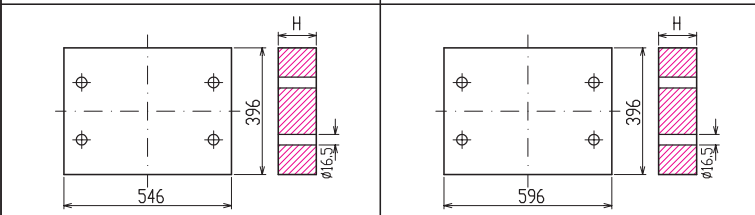
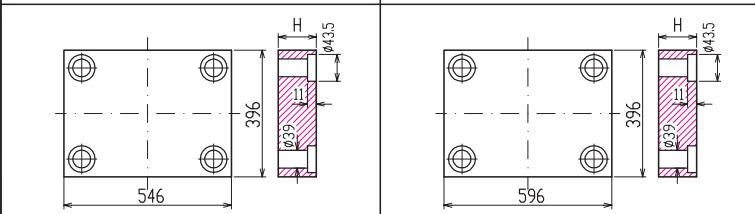
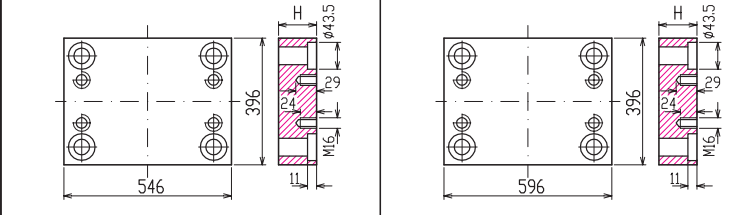

KOLONLAR / PILLARS

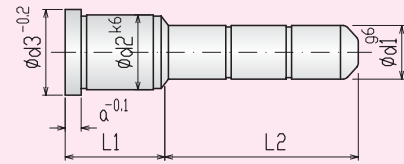

S			K			L2											
d1	d2	d3	a	L1	L2	36	46	56	66	76	86	96	106	116	126	136	146
30	39	43	10	36	46	56	66	76	86	96	106	116					

BURÇLAR / GUIDE BUSHES

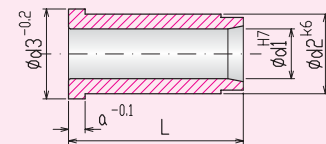

S			B			L									
d1	d2	d3	a	L1	L2	36	46	56	66	76	86	96	106	116	
30	39	43	10	36	46	56	66	76	86	96	106	116			

ÇİVATALAR / SOCKET CAP SCREWS

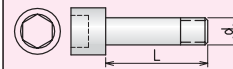

DIN 912 12.9

d	L	20	25	30	35	40	45	50	60	70	80	90	100	110	120	130	140	150	160	180	200	220	240	260	280
M10																									
M16																									

YAYLI RONDELA / SPRING WASHER

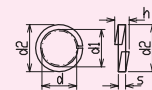

h <sub>max</sub>	d1	d2	d3	d4	d5
8.3	16.2	24.4	16	3.5	



# Ters Enjeksiyon Kalıp Seti 446 Serisi

## 446 Series of Reverse Injection Mold Base

te  
446

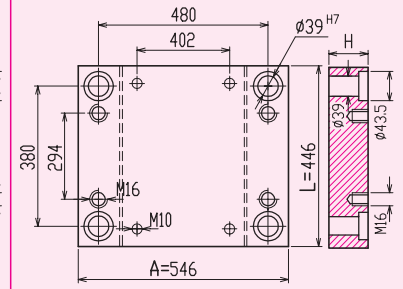
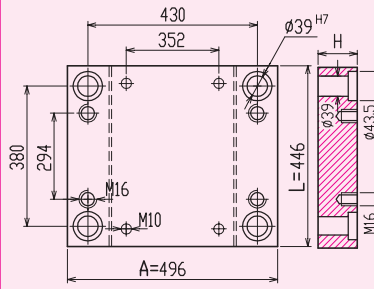
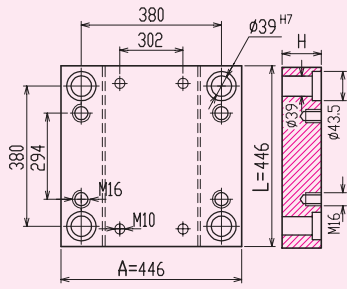

Plakalar / Plates	H	TE4444	TE4944	TE5444
<b>H1-H2</b> 	37			
	47			
	57			
	67			
	77			
	87			
	97			
	107			
<b>H6</b> 	37			
	47			
	57			
	67			
	77			
	87			
<b>H4</b> 	37			
	47			
	57			
	67			
<b>H3</b> 	77			
	87			
	97			
	107			
	117			
<b>H5-H9</b> 	37			
	47			
	57			
<b>H7</b> 	22			
	27			
<b>H8</b> 	27			





# Ters Enjeksiyon Kalıp Seti 446 Serisi

## 446 Series of Reverse Injection Mold Base

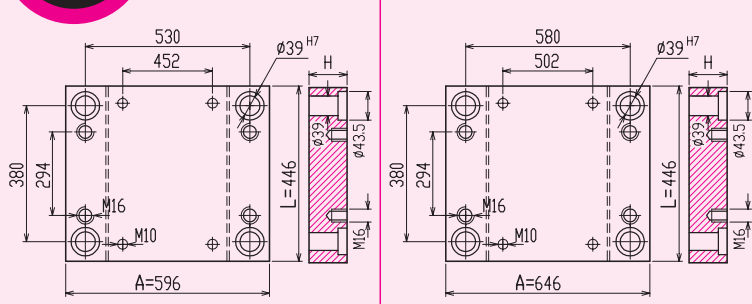

TE5944

TE6444

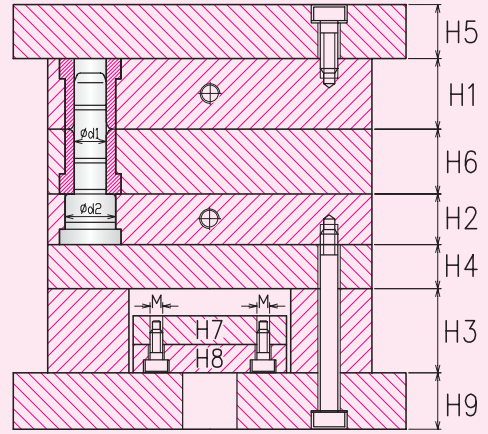
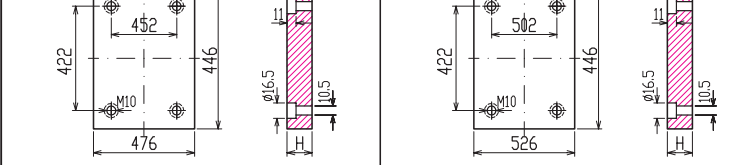
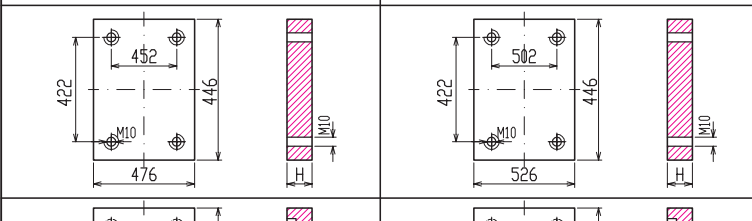
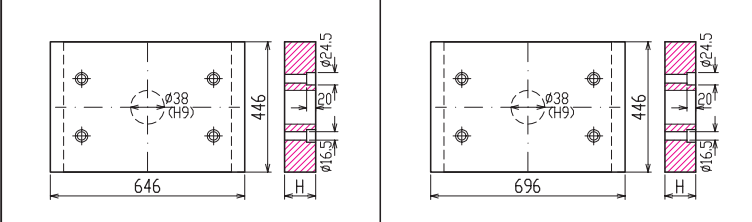
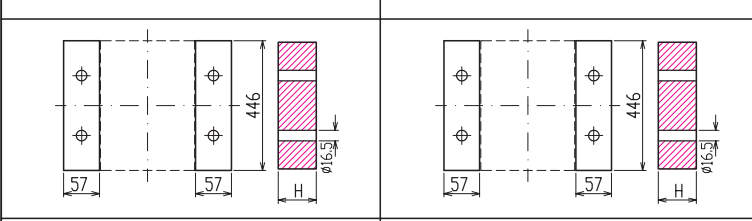
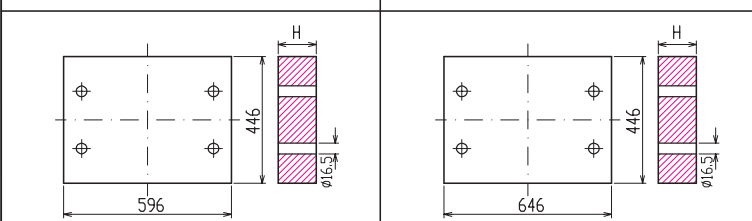
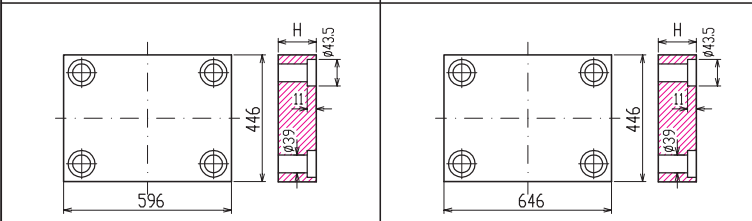
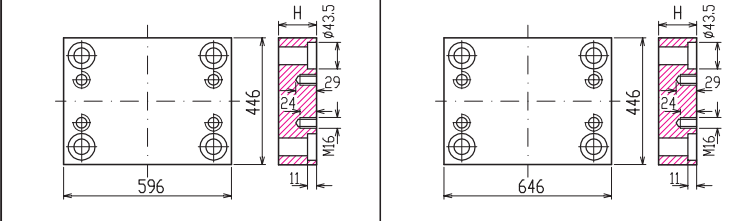

KOLONLAR / PILLARS

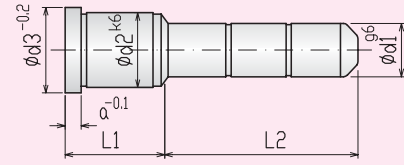

S K K			L2													
d1	d2	d3	a	L1	36	46	56	66	76	86	96	106	116	126	136	146
30	39	43	10	36	46	56	66	76	86	96	106	116	126	136	146	

BURÇLAR / GUIDE BUSHES

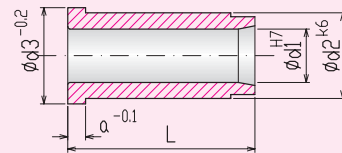

S B			L													
d1	d2	d3	a	36	46	56	66	76	86	96	106	116	126	136	146	
30	39	43	10	36	46	56	66	76	86	96	106	116	126	136	146	

ÇİVATALAR / SOCKET CAP SCREWS

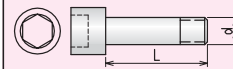

DIN 912 12.9

d	L	20	25	30	35	40	45	50	60	70	80	90	100	110	120	130	140	150	160	180	200	220	240	260	280
M10																									
M16																									

YAYLI RONDELA / SPRING WASHER

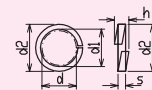

h <sub>max</sub>	d1	d2	d	s
8.3	16.2	24.4	16	3.5



# Ters Enjeksiyon Kalıp Seti 496 Serisi

## 496 Series of Reverse Injection Mold Base

te  
496

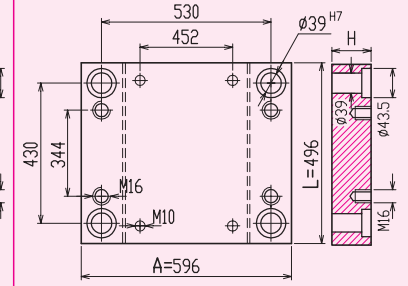
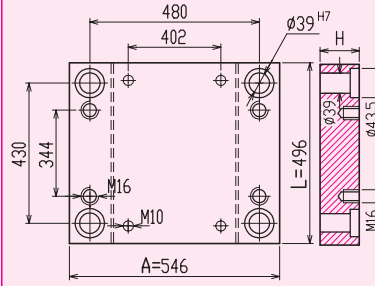
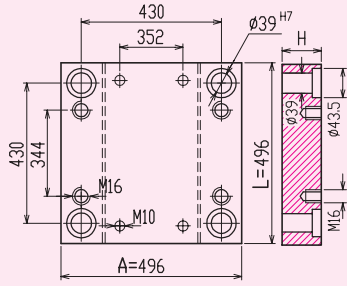

Plakalar / Plates	H	TE4949	TE5449	TE5949
 H1 H2	37			
	47			
	57			
	67			
	77			
	87			
	97			
	107			
 H6	37			
	47			
	57			
	67			
	77			
 H4	37			
	47			
	57			
	67			
 H3	77			
	87			
	97			
	107			
	117			
 H5 H9	37			
	47			
	57			
 H7	22			
	27			
 H8	27			



# Ters Enjeksiyon Kalıp Seti 496 Serisi

## 496 Series of Reverse Injection Mold Base

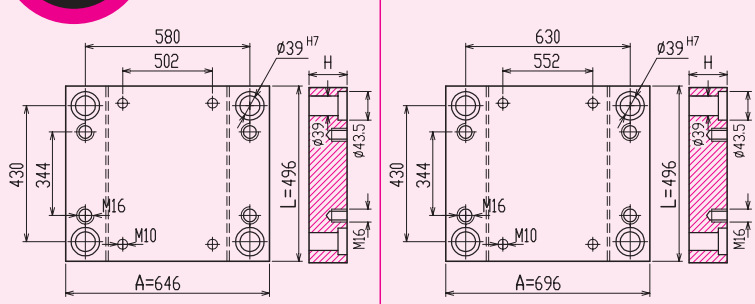

TE6449

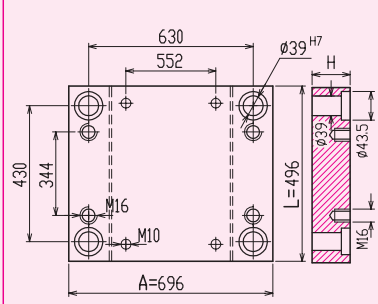

TE6949

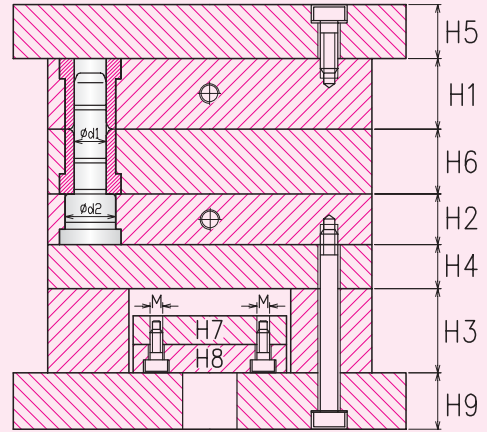
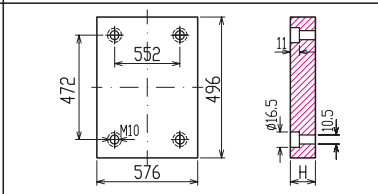
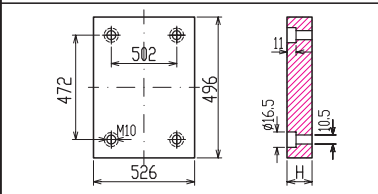
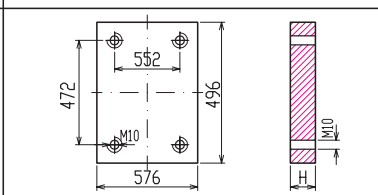
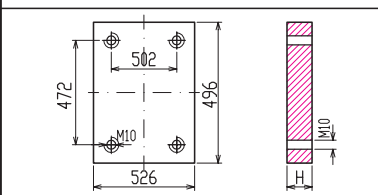
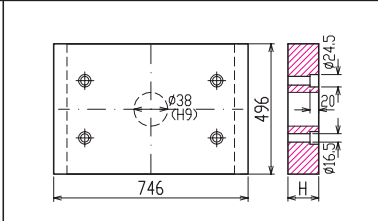
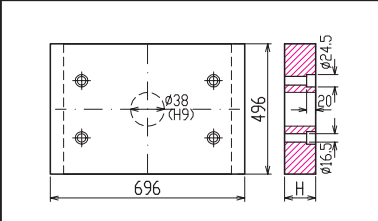
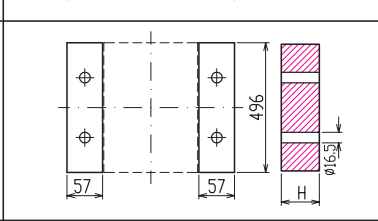
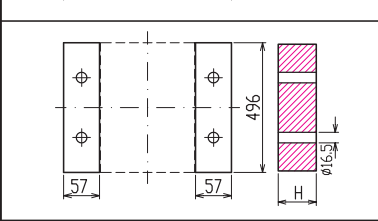
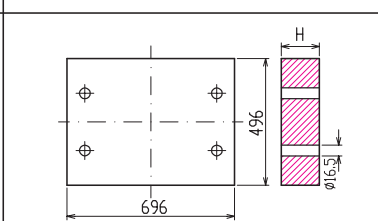
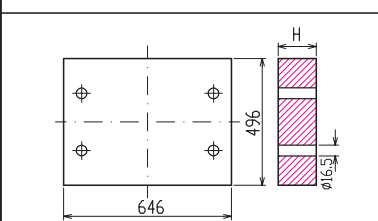
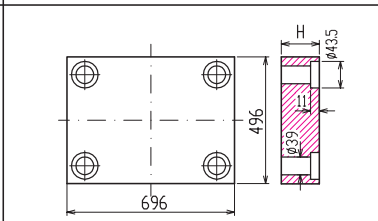
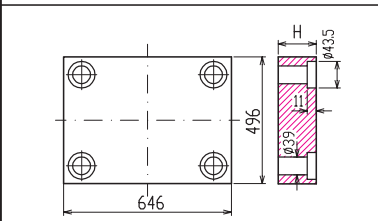
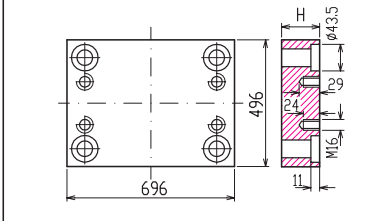
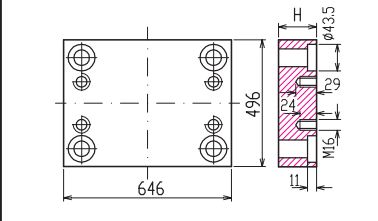

### KOLONLAR / PILLARS

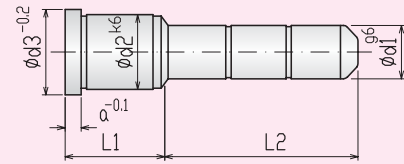

S			K			L2										
d1	d2	d3	a	L1	36	46	56	66	76	86	96	106	116	126	136	146
30	39	43	10	36	46	56	66	76	86	96	106	116	126	136	146	

### BURÇLAR / GUIDE BUSHES

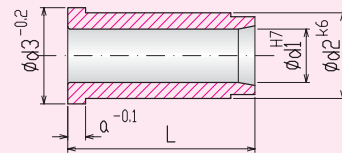

S			B			L						
d1	d2	d3	a	36	46	56	66	76	86	96	106	116
30	39	43	10	36	46	56	66	76	86	96	106	116

### ÇİVATALAR / SOCKET CAP SCREWS

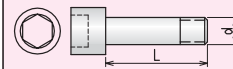

DIN 912 12.9

d	L	20	25	30	35	40	45	50	60	70	80	90	100	110	120	130	140	150	160	180	200	220	240	260	280
M10																									
M16																									

### YAYLI RONDELA / SPRING WASHER

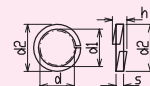

h <sub>max</sub>	d1	d2	d	s
8.3	16.2	24.4	16	3.5



# Ters Enjeksiyon Kalıp Seti 546 Serisi

## 546 Series of Reverse Injection Mold Base

te  
546

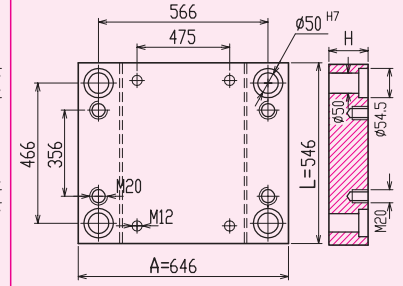
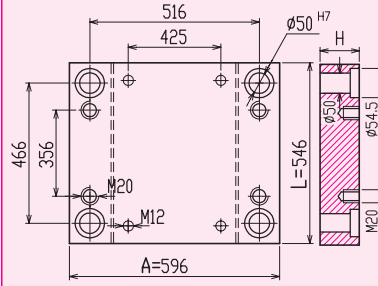
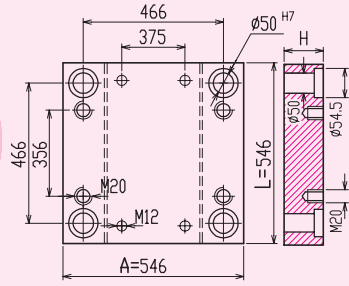

Plakalar / Plates	H	TE5454	TE5954	TE6454
<b>H1-H2</b> 	47			
	57			
	67			
	77			
	87			
	97			
	107			
	117			
<b>H6</b> 	47			
	57			
	67			
	77			
	87			
	97			
	107			
	117			
<b>H4</b> 	47			
	57			
	67			
	77			
	77			
<b>H3</b> 	77			
	87			
	97			
	107			
	117			
	127			
	137			
<b>H5-H9</b> 	47			
	57			
	67			
<b>H7</b> 	22			
	27			
<b>H8</b> 	27			
	37			



# Ters Enjeksiyon Kalıp Seti 546 Serisi

## 546 Series of Reverse Injection Mold Base

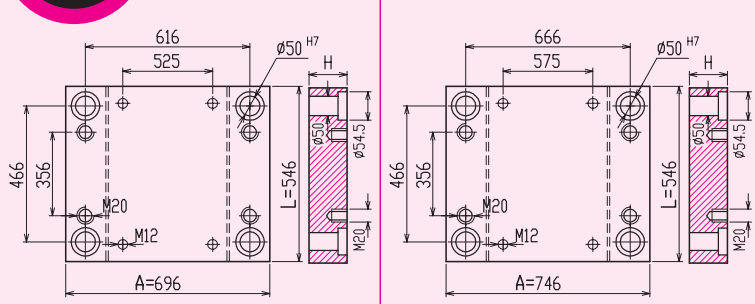

TE6954

TE7454

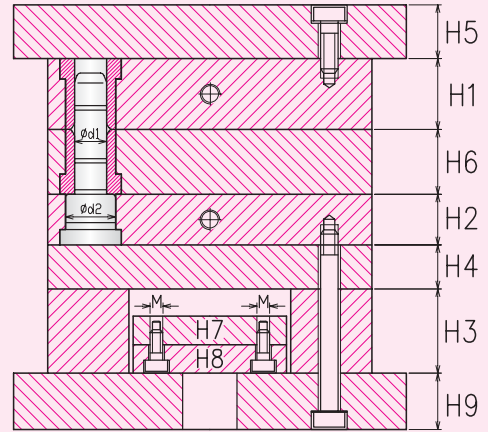
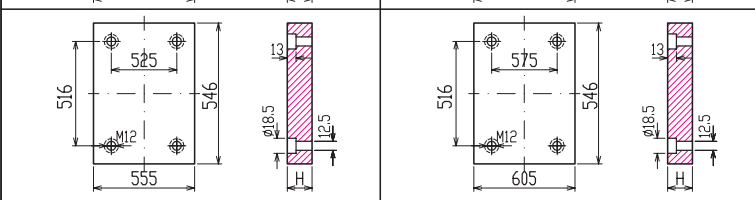
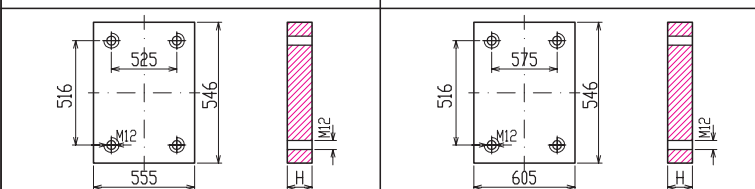
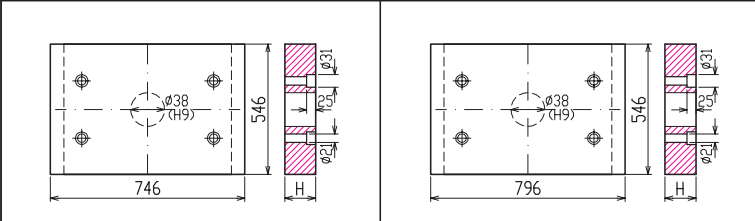
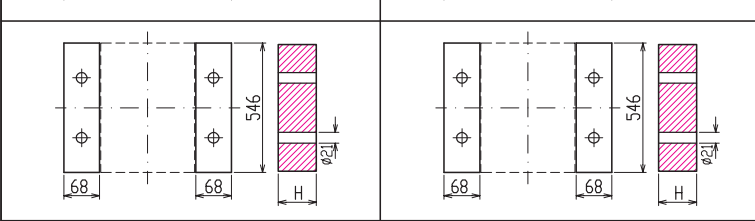
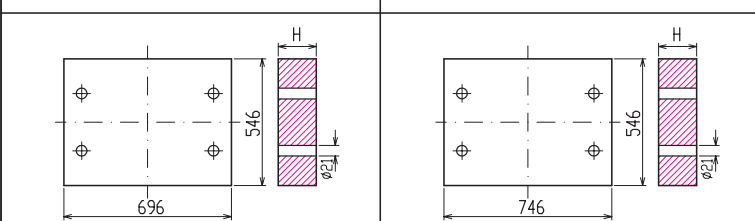
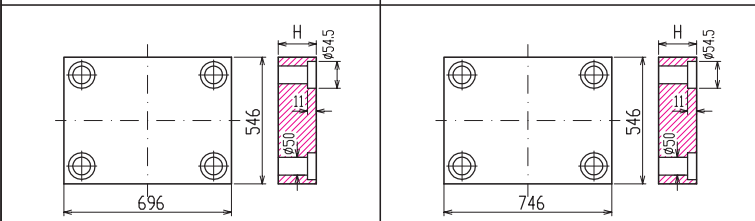
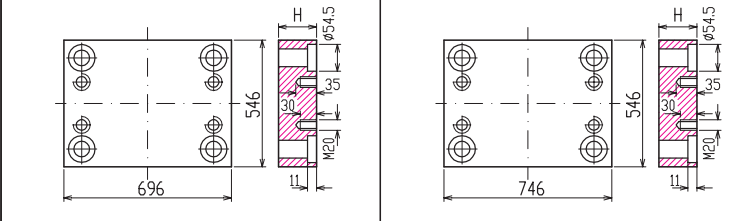

### KOLONLAR / PILLARS

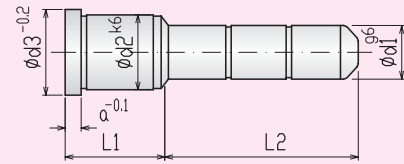

S			L2														
d1	d2	d3	a	L1	46	56	66	76	86	96	106	116	126	136	146	156	
40	50	54	10	46	56	66	76	86	96	106	116	126	STOKLARDA MEVCUT DEĞİLDİR ÖZEL OLARAK İMAL EDİLİR (NOT IN STOCK CUSTOM BUILD)				

### BURÇLAR / GUIDE BUSHES

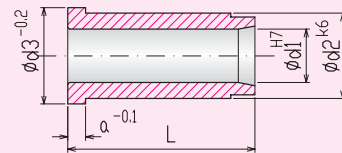

S			L														
d1	d2	d3	a	46	56	66	76	86	96	106	116	126					
40	50	54	10	ÖZEL OLARAK İMAL EDİLİR (CUSTOM BUILD)													

### ÇİVATALAR / SOCKET CAP SCREWS

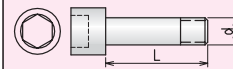

DIN 912 12.9

d	L	25	30	35	40	45	50	60	70	80	90	100	110	120	130	140	150	160	180	200	220	240	260	280	300	
M12																										
M20																										

### YAYLI RONDELA / SPRING WASHER

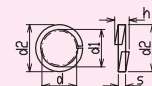

h <sub>max</sub>	d1	d2	d	s
10.6	20.2	30.6	20	4.5



# Ters Enjeksiyon Kalıp Seti 596 Serisi

## 596 Series of Reverse Injection Mold Base

te  
596

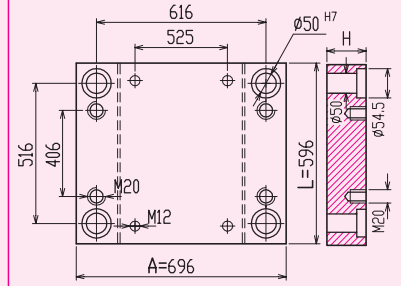
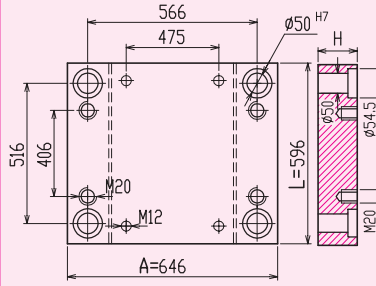
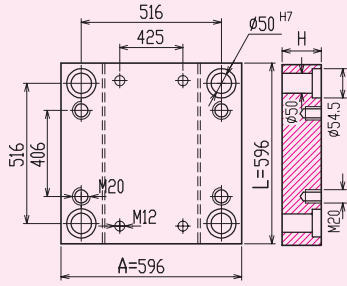

Plakalar / Plates	H	TE5959	TE6459	TE6959
<b>H1-H2</b> 	47			
	57			
	67			
	77			
	87			
	97			
	107			
<b>H6</b> 	47			
	57			
	67			
	77			
	87			
	97			
	107			
<b>H4</b> 	47			
	57			
	67			
	77			
<b>H3</b> 	77			
	87			
	97			
	107			
	117			
	127			
<b>H5-H9</b> 	47			
	57			
	67			
<b>H7</b> 	22			
	27			
<b>H8</b> 	27			
	37			



# Ters Enjeksiyon Kalıp Seti 596 Serisi

## 596 Series of Reverse Injection Mold Base

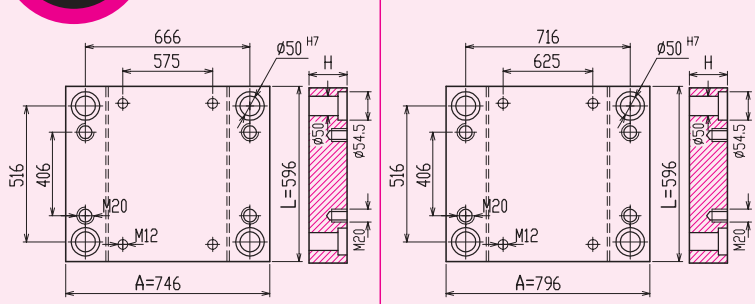

TE7459

TE7959

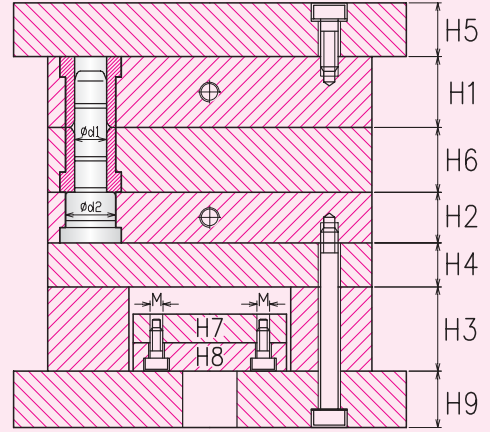
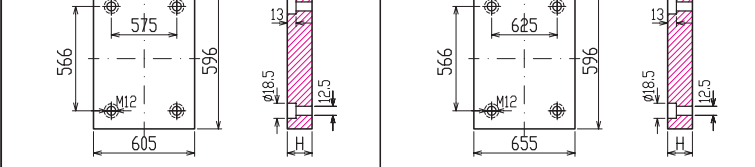
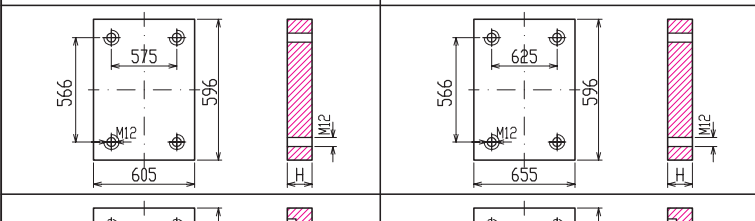
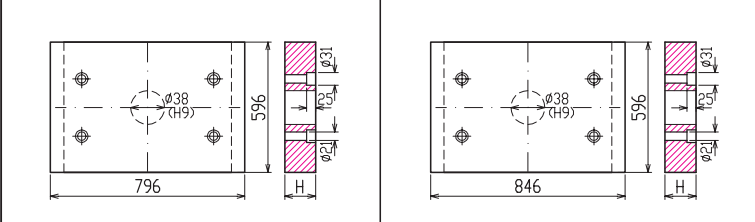
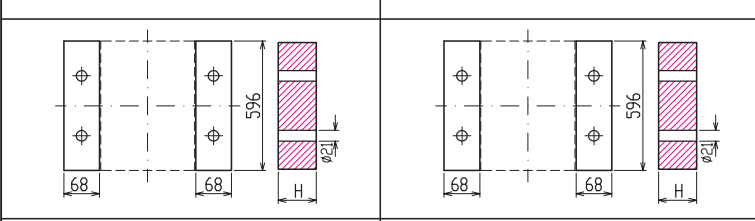
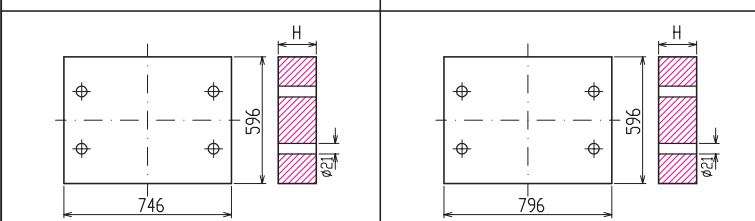
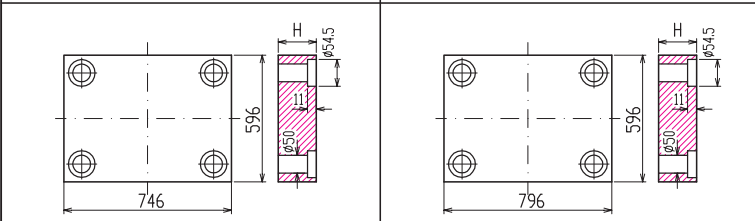
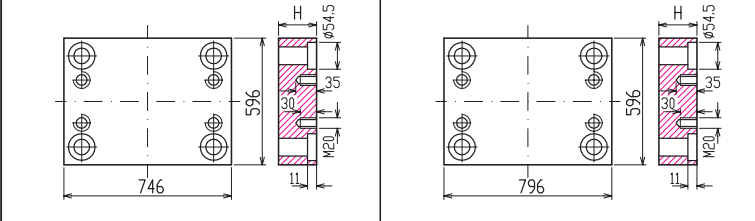

### KOLONLAR / PILLARS

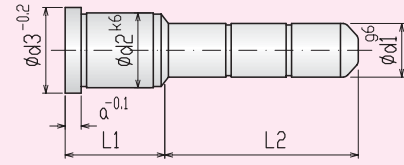

S K K			L2													
d1	d2	d3	a	L1	46	56	66	76	86	96	106	116	126	136	146	156
40	50	54	10	46	56	66	76	86	96	106	116	126	136	146	156	

STOKLARDA MEVCUT DEĞİLDİR  
ÖZEL OLARAK İMAL EDİLİR  
(NOT IN STOCK CUSTOM BUILD)

### BURÇLAR / GUIDE BUSHES

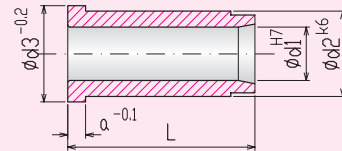

S B			L												
d1	d2	d3	a	46	56	66	76	86	96	106	116	126			
40	50	54	10	46	56	66	76	86	96	106	116	126			

ÖZEL OLARAK İMAL EDİLİR  
(CUSTOM BUILD)

### ÇİVATALAR / SOCKET CAP SCREWS

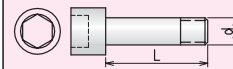

DIN 912 12.9

d	L	25	30	35	40	45	50	60	70	80	90	100	110	120	130	140	150	160	180	200	220	240	260	280	300	
M12																										
M20																										

### YAYLI RONDELA / SPRING WASHER

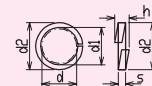

h <sub>max</sub>	d1	d2	d	s
10.6	20.2	30.6	20	4.5



# Ters Enjeksiyon Kalıp Seti 646 Serisi

## 646 Series of Reverse Injection Mold Base

te  
646

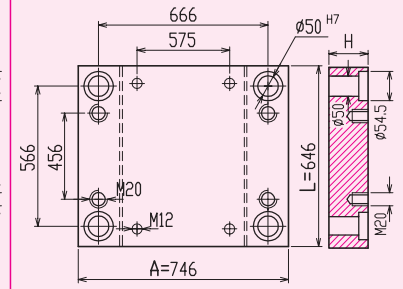
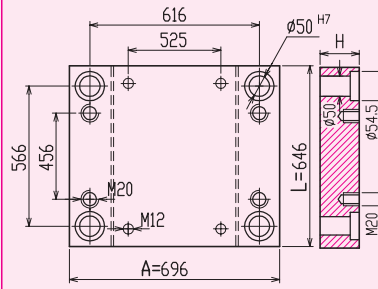
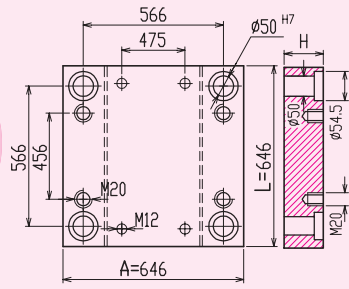

Plakalar / Plates	H	TE6464	TE6964	TE7464
<b>H1-H2</b> 	47			
	57			
	67			
	77			
	87			
	97			
	107			
	117			
<b>H6</b> 	47			
	57			
	67			
	77			
	87			
	97			
	107			
	117			
<b>H4</b> 	47			
	57			
	67			
	77			
	77			
<b>H3</b> 	77			
	87			
	97			
	107			
	117			
	127			
	137			
<b>H5-H9</b> 	47			
	57			
	67			
<b>H7</b> 	22			
	27			
<b>H8</b> 	27			
	37			





# Ters Enjeksiyon Kalıp Seti 646 Serisi

## 646 Series of Reverse Injection Mold Base

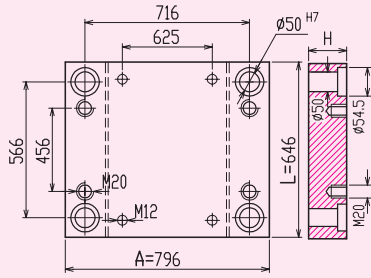

TE7964

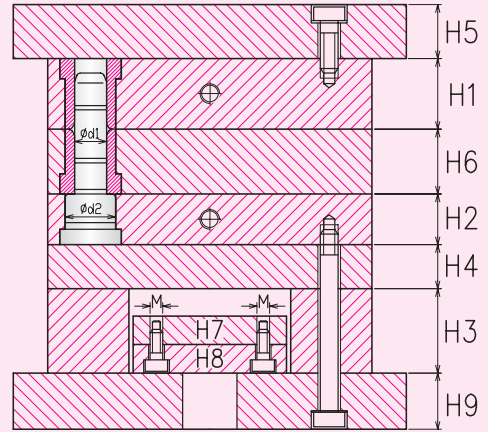
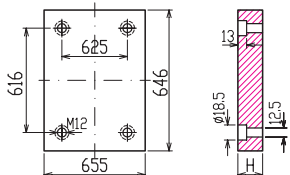
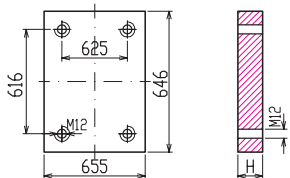
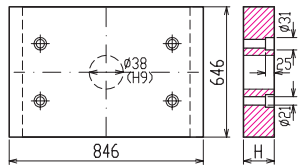
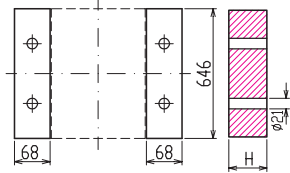
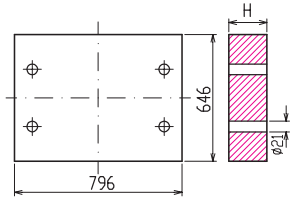
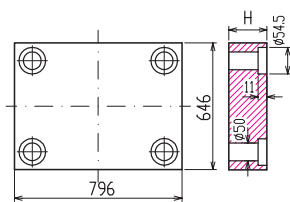
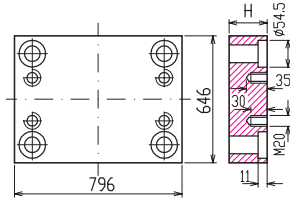

### KOLONLAR / PILLARS

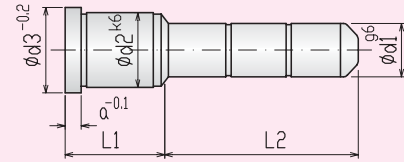

S			L2													
d1	d2	d3	a	L1	46	56	66	76	86	96	106	116	126	136	146	156
40	50	54	10	46	56	66	76	86	96	106	116	126	STOKLARDA MEVCUT DEĞİLDİR ÖZEL OLARAK İMAL EDİLİR (NOT IN STOCK CUSTOM BUILD)			

### BURÇLAR / GUIDE BUSHES

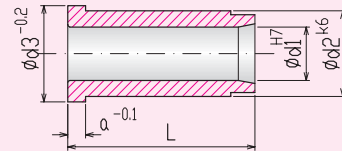

S			L												
d1	d2	d3	a	46	56	66	76	86	96	106	116	126			
40	50	54	10	ÖZEL OLARAK İMAL EDİLİR (CUSTOM BUILD)											

### ÇİVATALAR / SOCKET CAP SCREWS

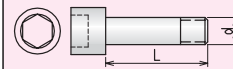

DIN 912 12.9

d	L	25	30	35	40	45	50	60	70	80	90	100	110	120	130	140	150	160	180	200	220	240	260	280	300	
M12																										
M20																										

### YAYLI RONDELA / SPRING WASHER

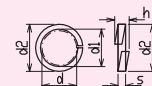

h <sub>max</sub>	d1	d2	d3	s
10.6	20.2	30.6	20	4.5



# Ters Enjeksiyon Kalıp Seti 696 Serisi

## 696 Series of Reverse Injection Mold Base

te  
696

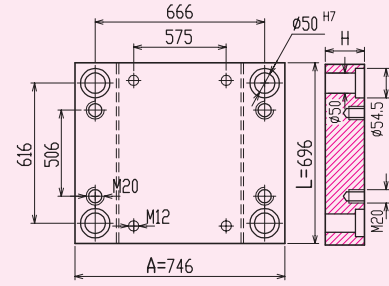
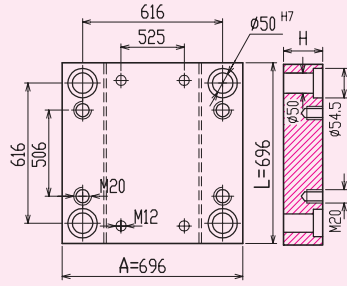

Plakalar / Plates	H	TE6969	TE7469
H1-H2 	47		
	57		
	67		
	77		
	87		
	97		
	107		
	117		
H6 	47		
	57		
	67		
	77		
	87		
	97		
H4 	47		
	57		
	67		
	77		
H3 	77		
	87		
	97		
	107		
	117		
	127		
H5-H9 	47		
	57		
	67		
H7 	22		
	27		
H8 	27		
	37		



# Ters Enjeksiyon Kalıp Seti 696 Serisi

## 696 Series of Reverse Injection Mold Base

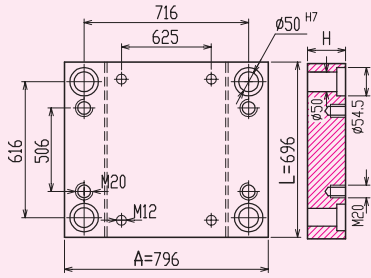

TE7969

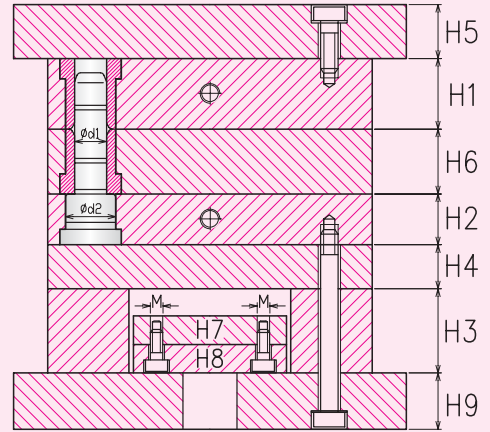
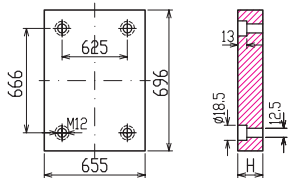
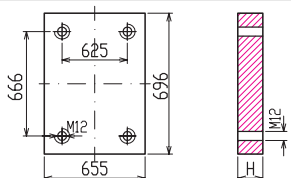
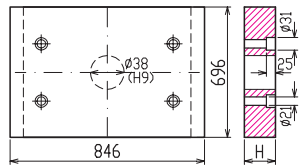
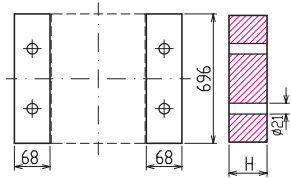
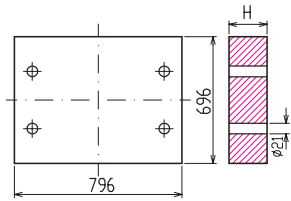
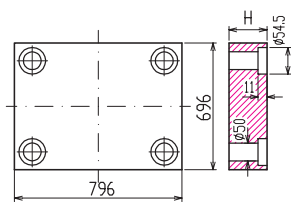
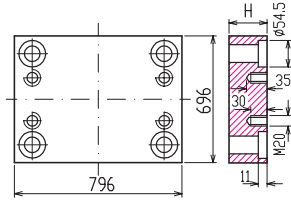

KOLONLAR / PILLARS

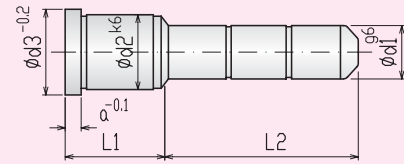

S			L2													
d1	d2	d3	a	L1	46	56	66	76	86	96	106	116	126	136	146	156
40	50	54	10	46	56	66	76	86	96	106	116	126	136	146	156	

STOKLARDA MEVCUT DEĞİLDİR  
ÖZEL OLARAK İMAL EDİLİR  
(NOT IN STOCK CUSTOM BUILD)

BURÇLAR / GUIDE BUSHES

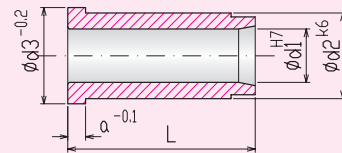

S			L												
d1	d2	d3	a	46	56	66	76	86	96	106	116	126			
40	50	54	10	46	56	66	76	86	96	106	116	126			

ÖZEL OLARAK İMAL EDİLİR  
(CUSTOM BUILD)

ÇİVATALAR / SOCKET CAP SCREWS

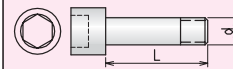

DIN 912 12.9

d	L	25	30	35	40	45	50	60	70	80	90	100	110	120	130	140	150	160	180	200	220	240	260	280	300
M12																									
M20																									

YAYLI RONDELA / SPRING WASHER

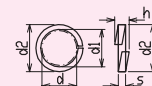

h <sub>max</sub>	d <sub>1</sub>	d <sub>2</sub>	d	s
10.6	20.2	30.6	20	4.5

**OKSET**  
PRODUCTION TURKEY 2004



2004 yılında

Okset Production Turkey 2004

Okset Production Turkey 2004

Okset Production Turkey 2004

Okset Production Turkey 2004

Okset Production Turkey 2004

Okset Production Turkey 2004

Okset Production Turkey 2004

Okset Production Turkey 2004

Okset Production Turkey 2004

Okset Production Turkey 2004

Okset Production Turkey 2004

Okset Production Turkey 2004

Okset Production Turkey 2004

Okset Production Turkey 2004

Okset Production Turkey 2004

Okset Production Turkey 2004

Okset Production Turkey 2004

Okset Production Turkey 2004

Okset Production Turkey 2004

Okset Production Turkey 2004

Okset Production Turkey 2004

Okset Production Turkey 2004

Okset Production Turkey 2004

Okset Production Turkey 2004

Okset Production Turkey 2004

Okset Production Turkey 2004

Okset Production Turkey 2004

Okset Production Turkey 2004

Okset Production Turkey 2004

Okset Production Turkey 2004

Okset Production Turkey 2004

Okset Production Turkey 2004

Okset Production Turkey 2004

Okset Production Turkey 2004

Okset Production Turkey 2004

Okset Production Turkey 2004

Okset Production Turkey 2004

Okset Production Turkey 2004

Okset Production Turkey 2004



# Ters Enjeksiyon Kalıp Seti Kuyruklu

## Reverse Injection Mold Base with Locating Pillar

tek

serisi / series



EKS TEK Serisi

 **OKSET**®



# Ters Enjeksiyon Kalıp Seti Kuyruklu 156 Serisi

## Reverse Injection Mold Base 156 Series with Locating Pillar

tek  
156

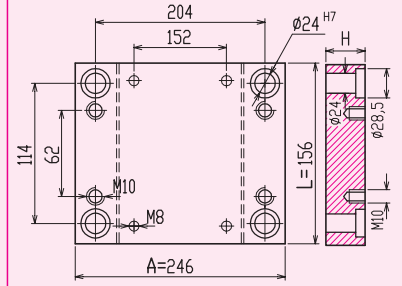
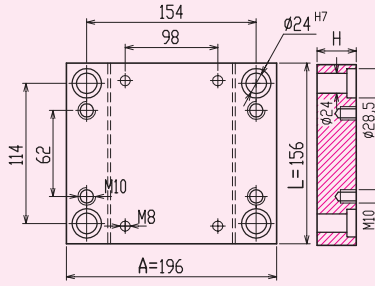
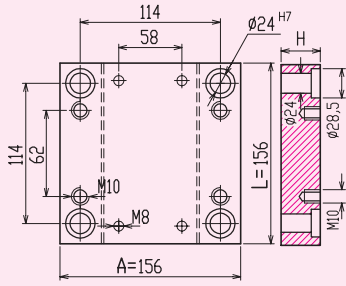

Plakalar / Plates	H	TEK1515	TEK1915	TEK2415
<b>H1-H2</b> 	27			
	37			
	47			
	57			
	67			
	77			
	87			
<b>H6</b> 	27			
	37			
	47			
	57			
	87			
<b>H4</b> 	27			
	37			
	47			
<b>H3</b> 	57			
	67			
	77			
<b>H5-H9</b> 	27			
<b>H7</b> 	14			
	17			
<b>H8</b> 	17			



# Ters Enjeksiyon Kalıp Seti Kuyruklu 156 Serisi

## Reverse Injection Mold Base 156 Series with Locating Pillar

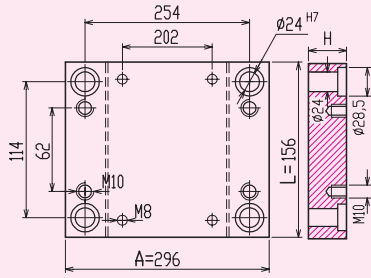

TEK2915

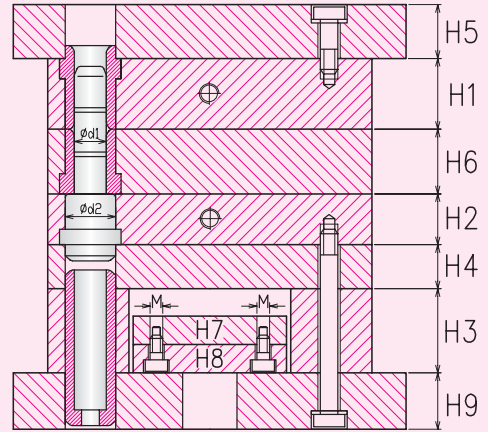
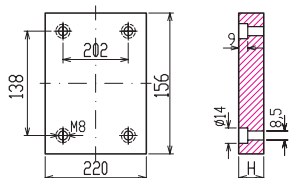
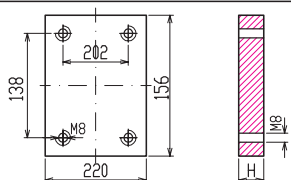
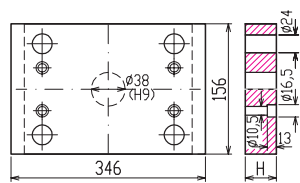
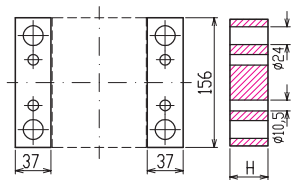
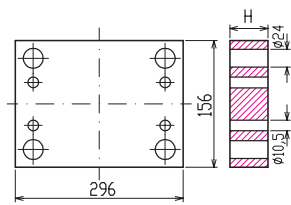
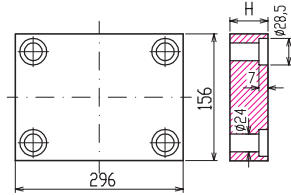
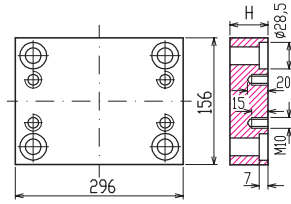

KOLONLAR / PILLARS

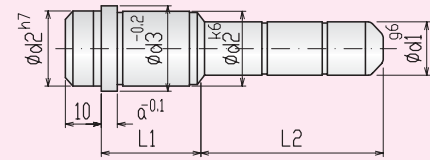

K S K K				L2													
d1	d2	d3	a	L1	26	36	46	56	66	76	86	96	106	116	126	136	146
16	24	28	6	26													
				36													
				46													
				56													
				66													
				76													
				86													
				96													
				106													
				116													
				126													
				136													
				146													

BURÇLAR / GUIDE BUSHES

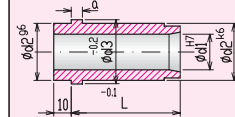

K S B				L						
d1	d2	d3	a	26	36	46	56	66	76	86
16	24	28	6							

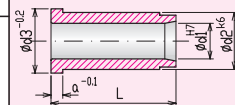

S B				L						
d1	d2	d3	a	26	36	46	56	66	76	86
16	24	28	6							

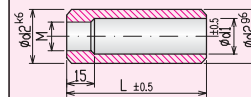

D T B				L					
d1	d2	M	a	60	80	100	120	140	160
16	24	M8							

ÇİVATALAR / SOCKET CAP SCREWS

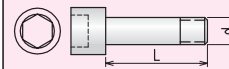

DIN 912 12.9

d	L	20	25	30	35	40	45	50	60	70	80	90	100	110	120	130	140	150	160	180	200	220	240	260	280
M8																									
M10																									

YAYLI RONDELA / SPRING WASHER

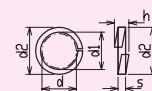

h <sub>max</sub>	d1	d2	d	s
5.9	10.2	16	10	2.5



# Ters Enjeksiyon Kalıp Seti Kuyruklu 196 Serisi

## Reverse Injection Mold Base 196 Series with Locating Pillar

tek  
196

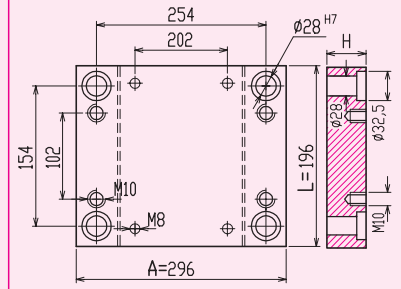
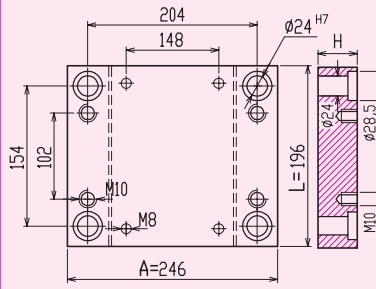
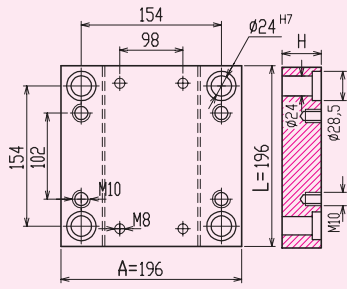

Plakalar / Plates	H	TEK1919	TEK2419	TEK2919
<b>H1-H2</b> 	27			
	37			
	47			
	57			
	67			
	77			
	87			
<b>H6</b> 	27			
	37			
	47			
	57			
	87			
<b>H4</b> 	27			
	37			
	47			
<b>H3</b> 	57			
	67			
	77			
<b>H5-H9</b> 	27			
<b>H7</b> 	14			
	17			
<b>H8</b> 	17			





# Ters Enjeksiyon Kalıp Seti Kuyruklu 196 Serisi

## Reverse Injection Mold Base 196 Series with Locating Pillar

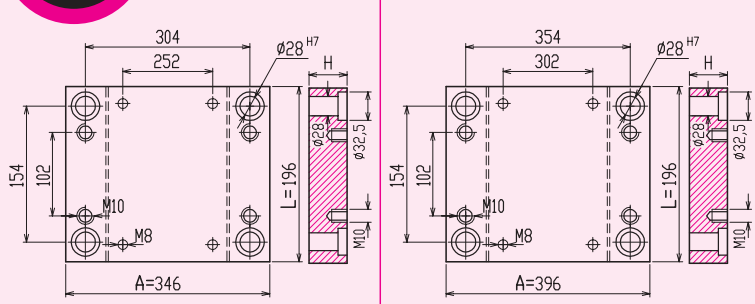

TEK3419

TEK3919

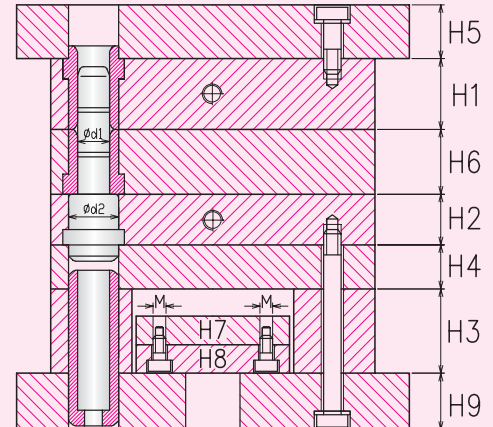
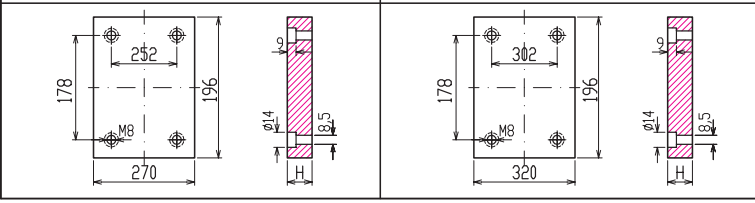
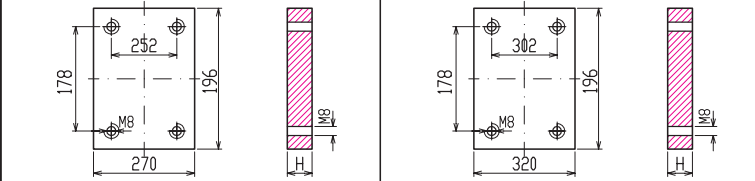
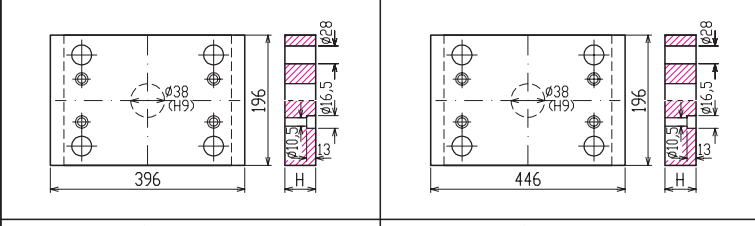
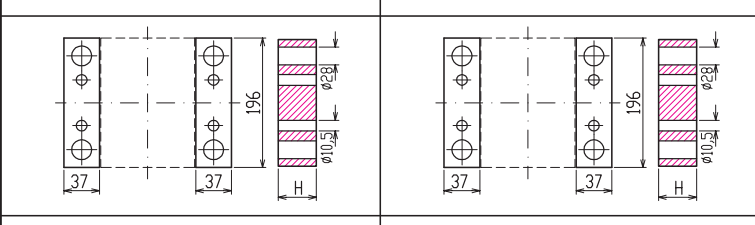
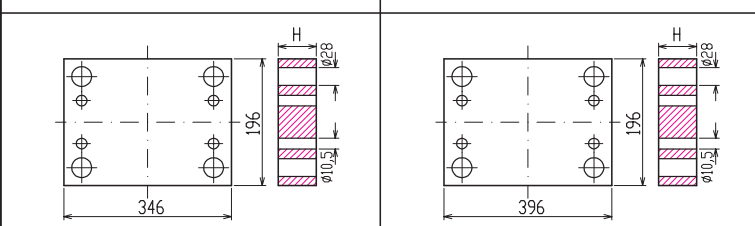
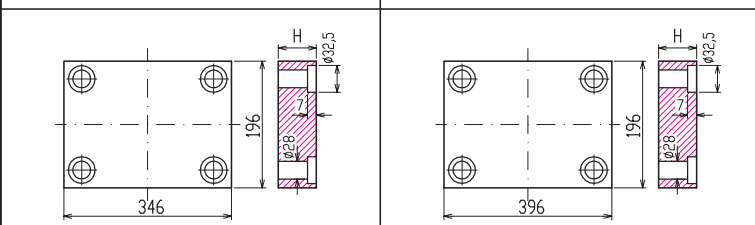
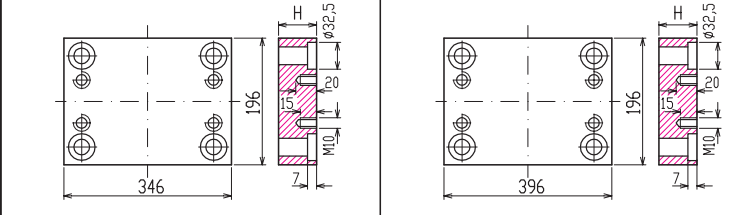

### KOLONLAR / PILLARS

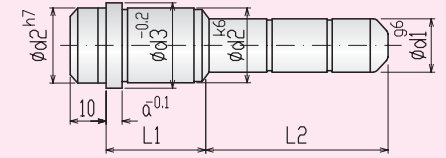

K S K K		L2															
d1	d2	d3	a	L1	26	36	46	56	66	76	86	96	106	116	126	136	146
16	24	28	6	26	36	46	56	66	76	86	96	106	116	126	136	146	
20	28	32	6	26	36	46	56	66	76	86	96	106	116	126	136	146	

### BURÇLAR / GUIDE BUSHES

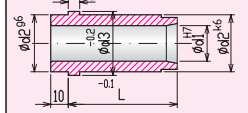

K S B		L									
d1	d2	d3	a	26	36	46	56	66	76	86	96
16	24	28	6								
20	28	32	6								

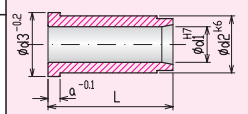

S B		L									
d1	d2	d3	a	26	36	46	56	66	76	86	96
16	24	28	6								
20	28	32	6								

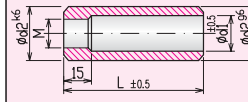

D T B		L						
d1	d2	M	60	80	100	120	140	160
16	24	M8						
20	28	M8						

### ÇİVATALAR / SOCKET CAP SCREWS

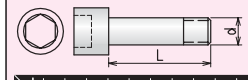

DIN 912 12.9

d	L	20	25	30	35	40	45	50	60	70	80	90	100	110	120	130	140	150	160	180	200	220	240	260	280
M8																									
M10																									

### YAYLI RONDELA / SPRING WASHER

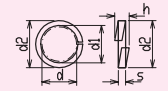

h <sub>max</sub>	d <sub>1</sub>	d <sub>2</sub>	d	s
5.9	10.2	16	10	2.5



# Ters Enjeksiyon Kalıp Seti Kuyruklu 246 Serisi

## Reverse Injection Mold Base 246 Series with Locating Pillar

tek  
246

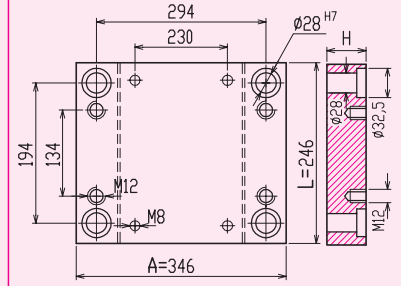
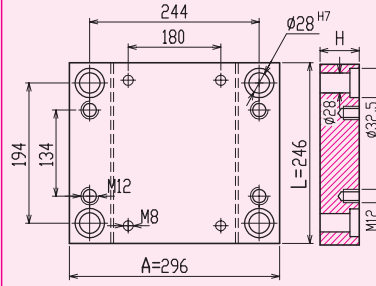
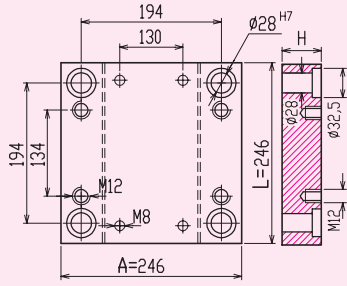

Plakalar / Plates	H	TEK2424	TEK2924	TEK3424
<b>H1-H2</b> 	27			
	37			
	47			
	57			
	67			
	77			
<b>H6</b> 	27			
	37			
	47			
	57			
<b>H4</b> 	27			
	37			
	47			
<b>H3</b> 	57			
	67			
	77			
	87			
	97			
<b>H5-H9</b> 	27			
	37			
<b>H7</b> 	14			
	17			
<b>H8</b> 	17			



# Ters Enjeksiyon Kalıp Seti Kuyruklu 246 Serisi

## Reverse Injection Mold Base 246 Series with Locating Pillar

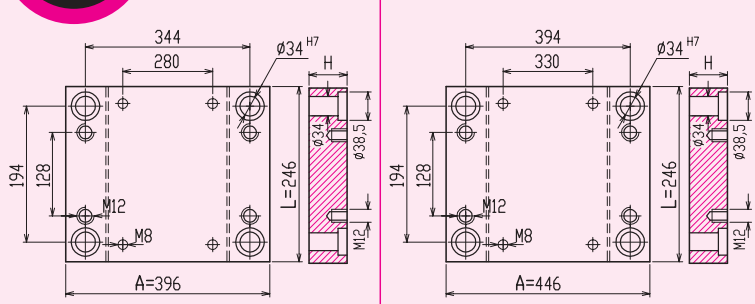

TEK3924

TEK4424

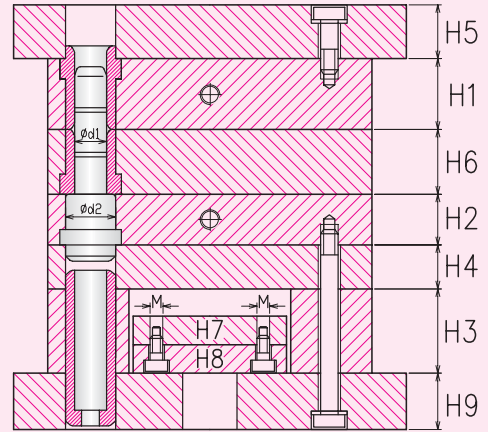
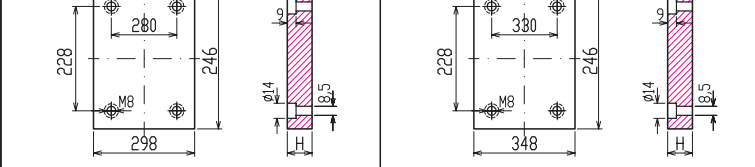
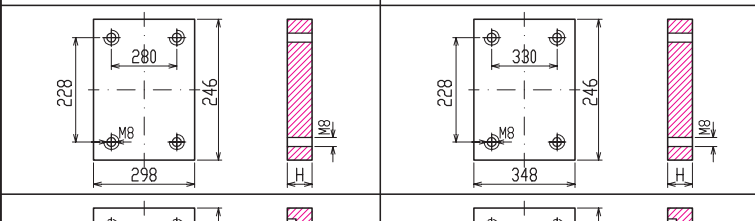
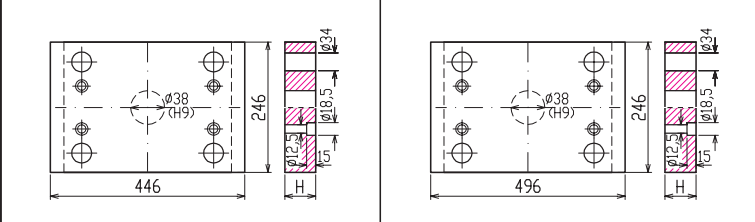
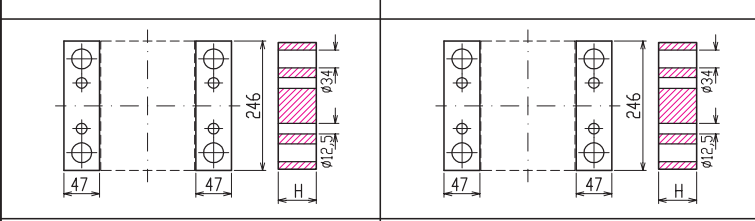
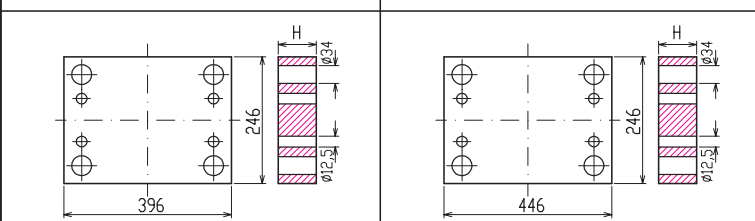
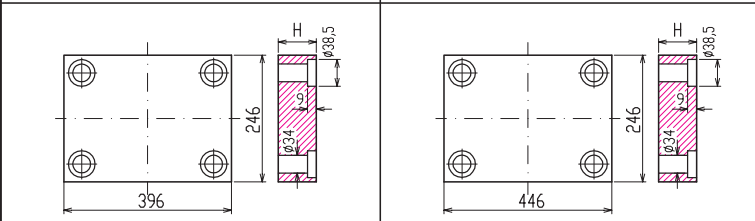
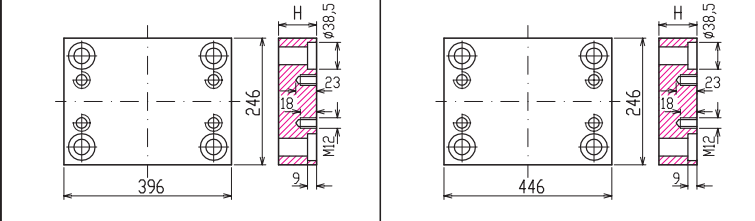

### KOLONLAR / PILLARS

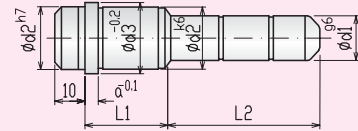

K S K K				L													
d1	d2	d3	a	26	36	46	56	66	76	86	96	106	116	126	136	146	
20	28	32	6	26	36	46	56	66	76	86	96	106	116	126	136	146	
				26	36	46	56	66	76	86	96	106	116	126	136	146	
				26	36	46	56	66	76	86	96	106	116	126	136	146	
				26	36	46	56	66	76	86	96	106	116	126	136	146	
				26	36	46	56	66	76	86	96	106	116	126	136	146	
				26	36	46	56	66	76	86	96	106	116	126	136	146	
25	34	38	8	26	36	46	56	66	76	86	96	106	116	126	136	146	
				26	36	46	56	66	76	86	96	106	116	126	136	146	
				26	36	46	56	66	76	86	96	106	116	126	136	146	
				26	36	46	56	66	76	86	96	106	116	126	136	146	
				26	36	46	56	66	76	86	96	106	116	126	136	146	
				26	36	46	56	66	76	86	96	106	116	126	136	146	

### BURÇLAR / GUIDE BUSHES

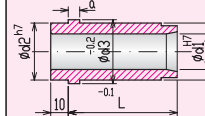

K S B				L									
d1	d2	d3	a	26	36	46	56	66	76	86	96	106	
20	28	32	6										
25	34	38	8										

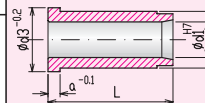

S B				L									
d1	d2	d3	a	26	36	46	56	66	76	86	96	106	
20	28	32	6										
25	34	38	8										

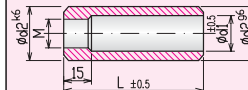

D T B			L					
d1	d2	M	60	80	100	120	140	160
20	28	M8						
25	34	M10						

### ÇİVATALAR / SOCKET CAP SCREWS

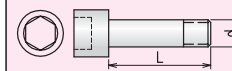

DIN 912 12.9

	20	25	30	35	40	45	50	60	70	80	90	100	110	120	130	140	150	160	180	200	220	240	260	280	
M8																									
M12																									

### YAYLI RONDELA / SPRING WASHER

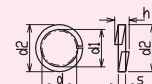

$h_{max}$	d1	d2	d	s
5.9	12.2	18	12	2.5



# Ters Enjeksiyon Kalıp Seti Kuyruklu 296 Serisi Reverse Injection Mold Base 296 Series with Locating Pillar

tek  
296

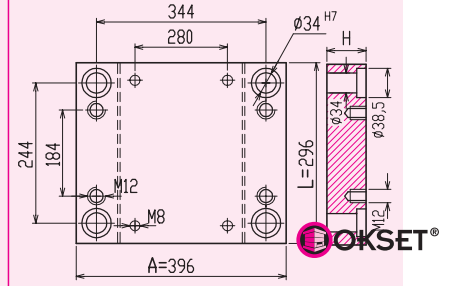
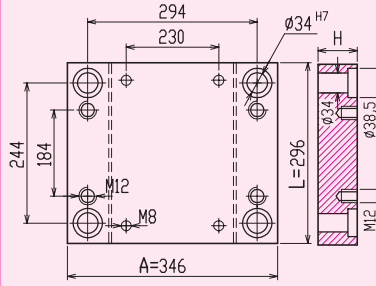
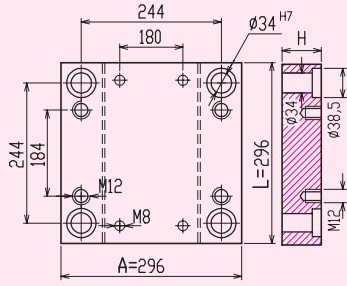

Plakalar / Plates	H	TEK2929	TEK3429	TEK3929
<b>H1-H2</b> 	27			
	37			
	47			
	57			
	67			
	77			
	87			
<b>H6</b> 	27			
	37			
	47			
	57			
	67			
<b>H4</b> 	27			
	37			
	47			
	57			
<b>H3</b> 	57			
	67			
	77			
	87			
	97			
<b>H5-H9</b> 	27			
	37			
<b>H7</b> 	17			
	22			
<b>H8</b> 	22			



# Ters Enjeksiyon Kalıp Seti Kuyruklu 296 Serisi

## Reverse Injection Mold Base 296 Series with Locating Pillar

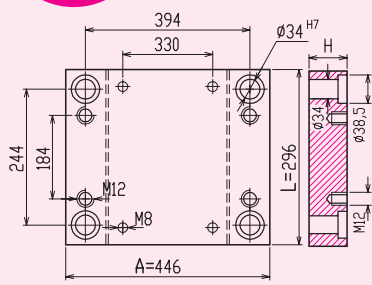

TEK4429

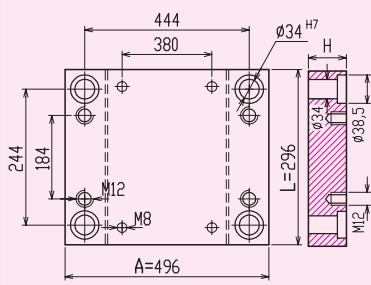

TEK4929

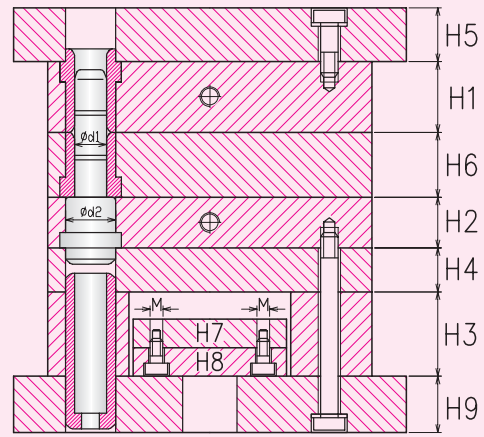
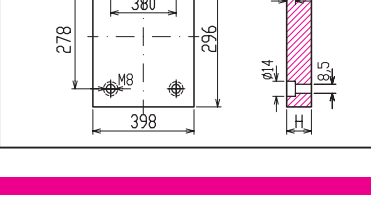
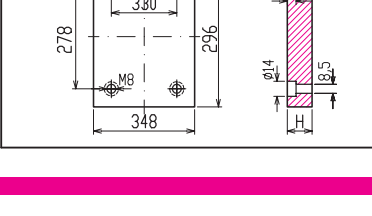
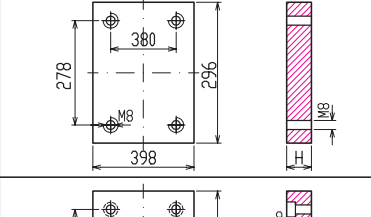
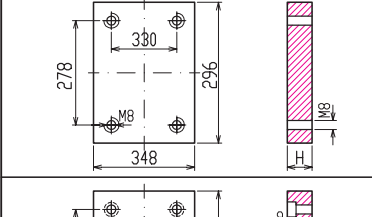
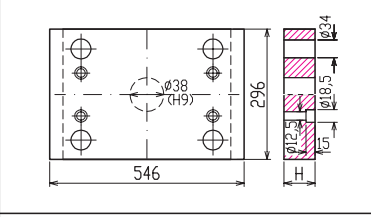
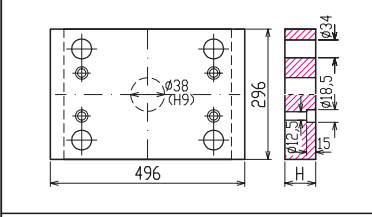
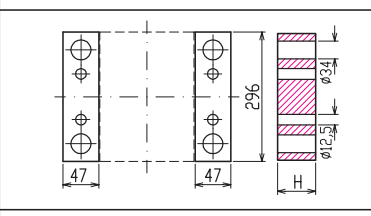
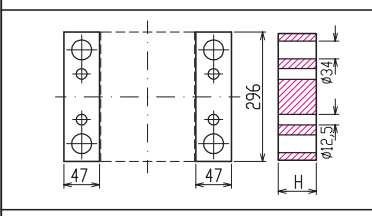
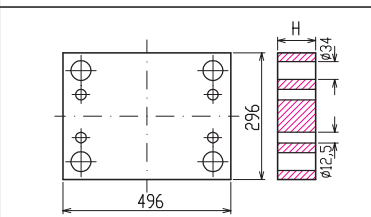
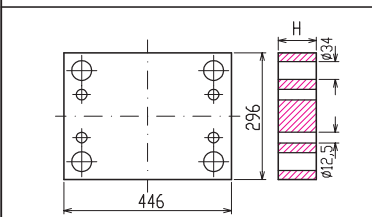
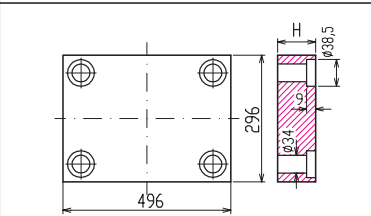
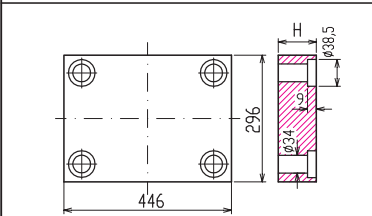
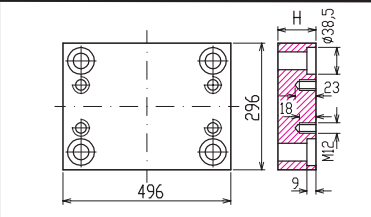
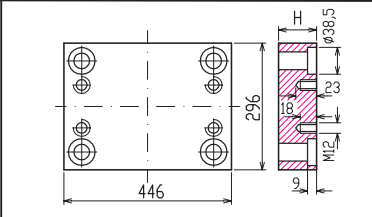

### KOLONLAR / PILLARS

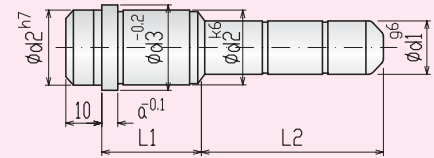

K S K K				L2												
d1	d2	d3	a	L1	36	46	56	66	76	86	96	106	116	126	136	146
25	34	38	8	26	36	46	56	66	76	86	96	106	116	126	136	146
				36	46	56	66	76	86	96	106	116	126	136	146	
				46	56	66	76	86	96	106	116	126	136	146		
				56	66	76	86	96	106	116	126	136	146			
				66	76	86	96	106	116	126	136	146				
				76	86	96	106	116	126	136	146					
				86	96	106	116	126	136	146						
				96	106	116	126	136	146							
				106	116	126	136	146								

### BURÇLAR / GUIDE BUSHES

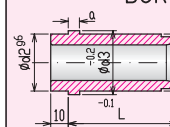

K S B				L										
d1	d2	d3	a	26	36	46	56	66	76	86	96	106		
25	34	38	8	26	36	46	56	66	76	86	96	106		
				36	46	56	66	76	86	96	106			
				46	56	66	76	86	96	106				
				56	66	76	86	96	106					
				66	76	86	96	106						
				76	86	96	106							
				86	96	106								
				96	106									
				106										

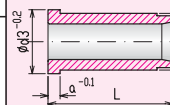

S B				L										
d1	d2	d3	a	26	36	46	56	66	76	86	96	106		
25	34	38	8	26	36	46	56	66	76	86	96	106		
				36	46	56	66	76	86	96	106			
				46	56	66	76	86	96	106				
				56	66	76	86	96	106					
				66	76	86	96	106						
				76	86	96	106							
				86	96	106								
				96	106									
				106										

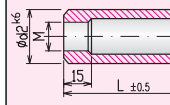

D T B				L					
d1	d2	M	a	60	80	100	120	140	160
25	34	M10	8	60	80	100	120	140	160
				80	100	120	140	160	
				100	120	140	160		
				120	140	160			
				140	160				
				160					

### ÇİVATALAR / SOCKET CAP SCREWS

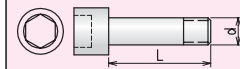

DIN 912 12.9

d	L	20	25	30	35	40	45	50	60	70	80	90	100	110	120	130	140	150	160	180	200	220	240	260	280	
M8																										
M12																										

### YAYLI RONDELA / SPRING WASHER

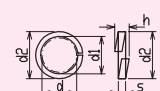

h <sub>max</sub>	d1	d2	d	s
5.9	12.2	18	12	2.5



# Ters Enjeksiyon Kalıp Seti Kuyruklu 346 Serisi

## Reverse Injection Mold Base 346 Series with Locating Pillar

tek  
346

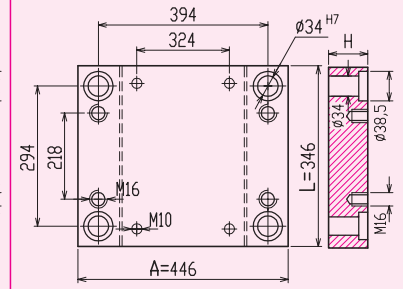
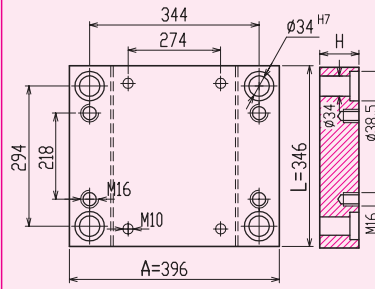
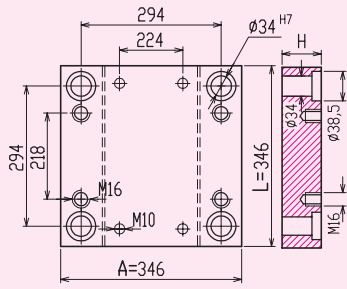

Plakalar / Plates	H	TEK3434	TEK3934	TEK4434
<b>H1-H2</b> 	37			
	47			
	57			
	67			
	77			
	87			
	97			
107				
<b>H6</b> 	27			
	37			
	47			
	57			
	67			
	77			
	87			
97				
107				
<b>H4</b> 	27			
	37			
	47			
	57			
<b>H3</b> 	57			
	67			
	77			
	87			
	97			
<b>H5-H9</b> 	37			
	47			
<b>H7</b> 	17			
	22			
<b>H8</b> 	22			



# Ters Enjeksiyon Kalıp Seti Kuyruklu 346 Serisi

## Reverse Injection Mold Base 346 Series with Locating Pillar

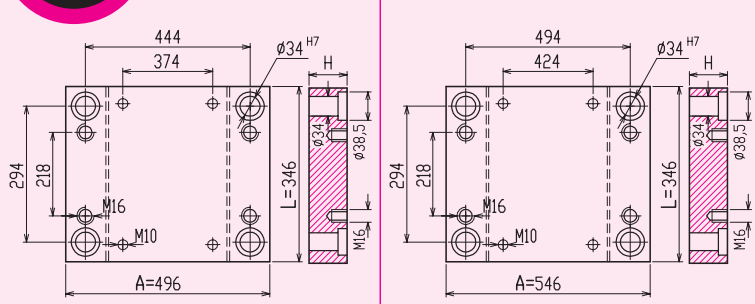

TEK4934

TEK5434

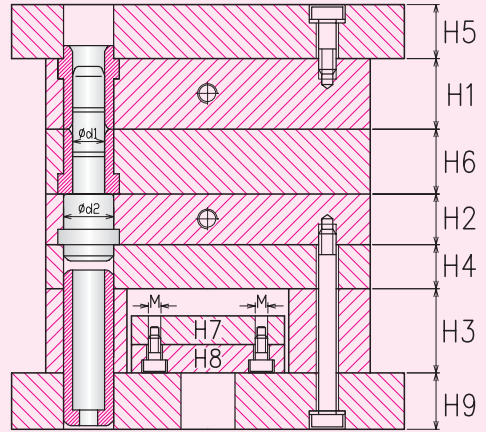
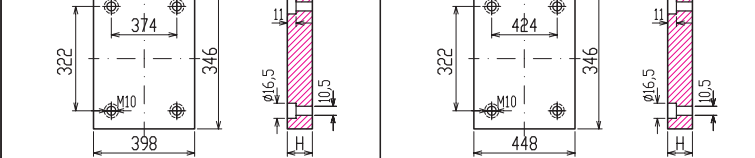
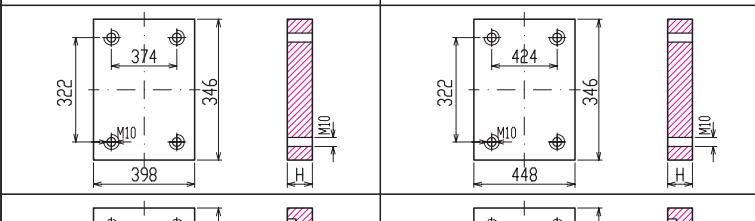
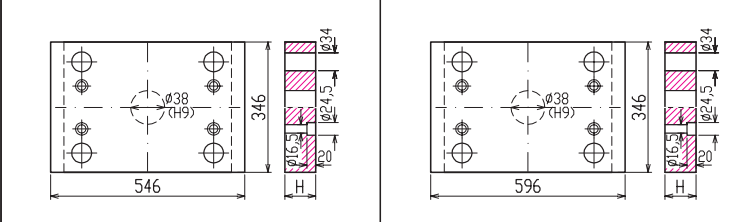
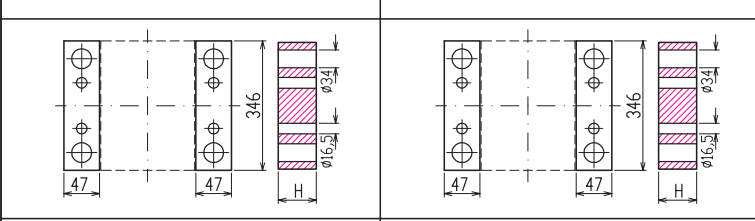
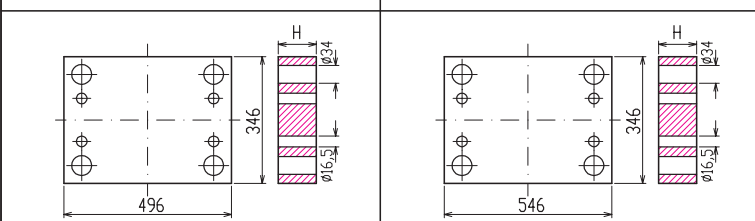
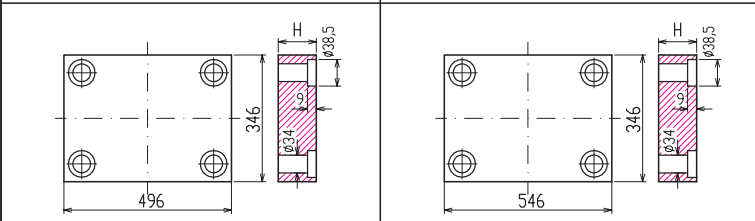
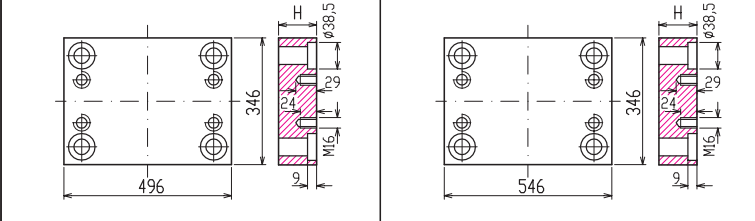

KOLONLAR / PILLARS

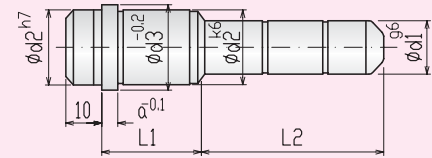

K S K K				L2												
d1	d2	d3	a	L1	36	46	56	66	76	86	96	106	116	126	136	146
25	34	38	8	26												
				36												
				46												
				56												
				66												
				76												
				86												
				96												
				106												

BURÇLAR / GUIDE BUSHES

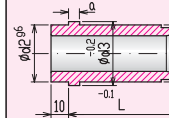

K S B				L										
d1	d2	d3	a	26	36	46	56	66	76	86	96	106		
25	34	38	8											

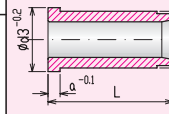

S B				L										
d1	d2	d3	a	26	36	46	56	66	76	86	96	106		
25	34	38	8											

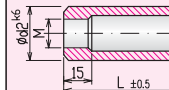

D T B				L				
d1	d2	M	80	100	120	140	160	
25	34	M10						

ÇİVATALAR / SOCKET CAP SCREWS

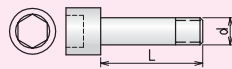

DIN 912 12.9

d	L	20	25	30	35	40	45	50	60	70	80	90	100	110	120	130	140	150	160	180	200	220	240	260	280
M10																									
M16																									

YAYLI RONDELA / SPRING WASHER

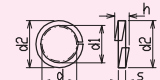

d <sub>max</sub>	d <sub>1</sub>	d <sub>2</sub>	d <sub>3</sub>	s
8.3	16.2	24.4	16	3.5



# Ters Enjeksiyon Kalıp Seti Kuyruklu 396 Serisi

## Reverse Injection Mold Base 396 Series with Locating Pillar

tek  
396

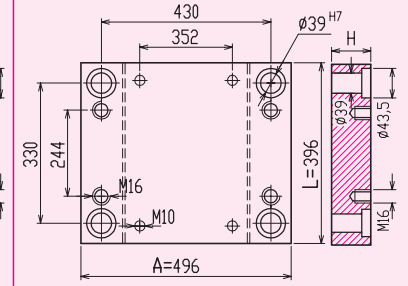
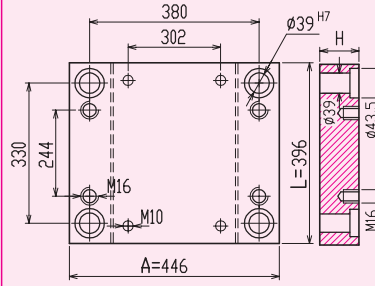
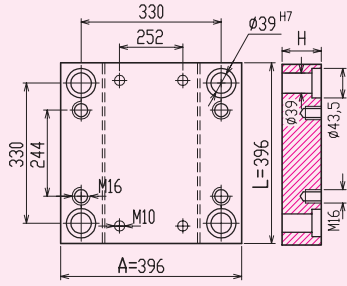

Plakalar / Plates	H	TEK3939	TEK4439	TEK4939
<b>H1-H2</b> 	37			
	47			
	57			
	67			
	77			
	87			
	97			
<b>H6</b> 	37			
	47			
	57			
	67			
	77			
<b>H4</b> 	27			
	37			
	47			
	57			
<b>H3</b> 	77			
	87			
	97			
	107			
	117			
<b>H5-H9</b> 	37			
	47			
	57			
<b>H7</b> 	22			
	27			
<b>H8</b> 	27			





# Ters Enjeksiyon Kalıp Seti Kuyruklu 396 Serisi Reverse Injection Mold Base 396 Series with Locating Pillar

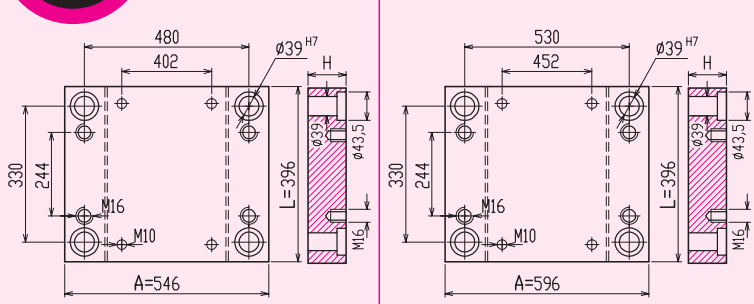

TEK5439

TEK5939

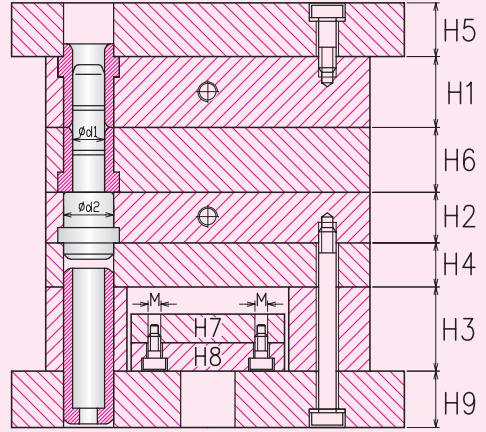
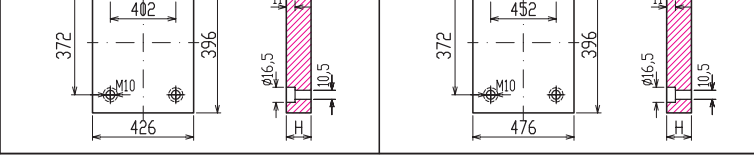
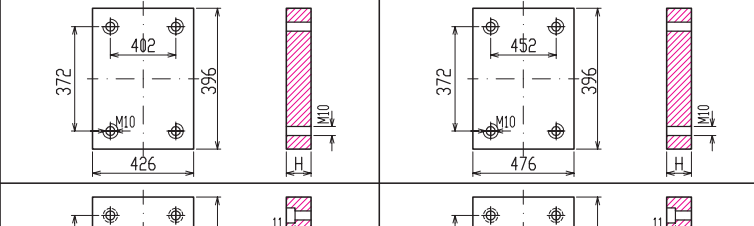
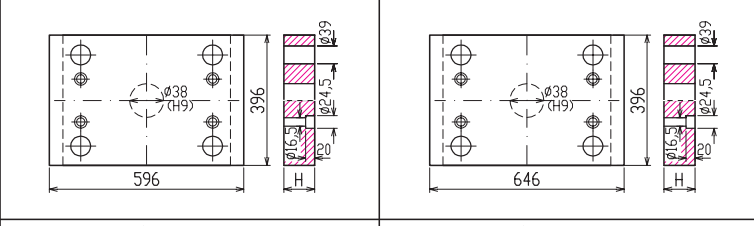
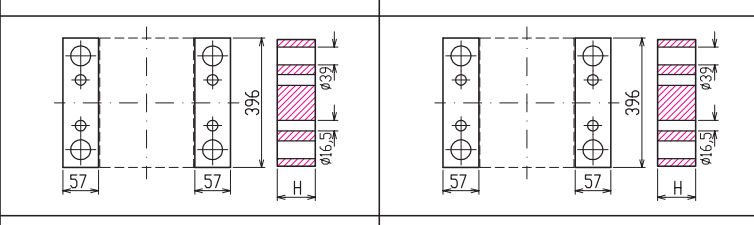
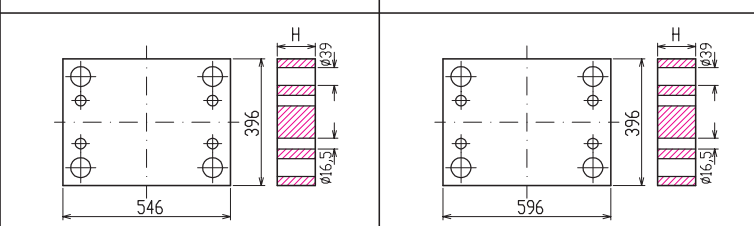
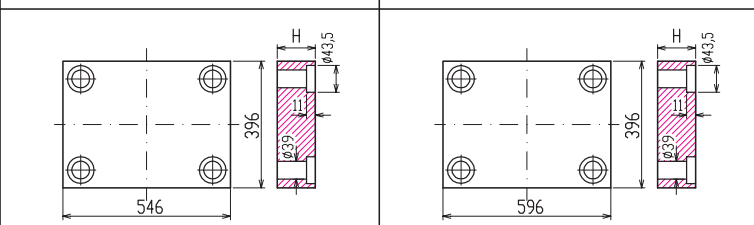
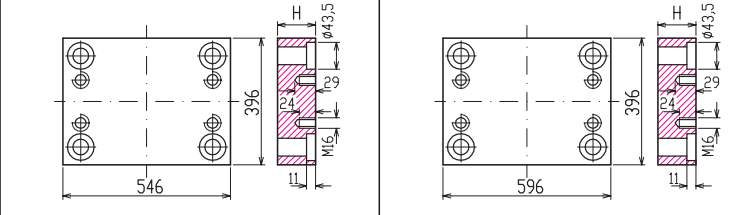

## KOLONLAR / PILLARS

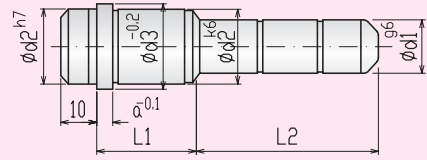

K S K K				L2											
d1	d2	d3	a	L1	36	46	56	66	76	86	96	106	116	126	136
30	39	43	10	36											
				46											
				56											
				66											
				76											
				86											
				96											
				106											
				116											

## BURÇLAR / GUIDE BUSHES

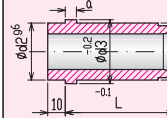

K S B				L								
d1	d2	d3	a	36	46	56	66	76	86	96	106	116
30	39	43	10									

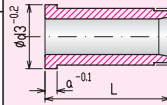

S B				L								
d1	d2	d3	a	36	46	56	66	76	86	96	106	116
30	39	43	10									

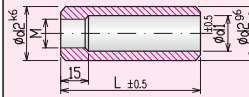

D T B				L				
d1	d2	M	a	80	100	120	140	160
30	39	M10						

## ÇİVATALAR / SOCKET CAP SCREWS

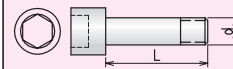

DIN 912 12.9

d	L	20	25	30	35	40	45	50	60	70	80	90	100	110	120	130	140	150	160	180	200	220	240	260	280
M10																									
M16																									

## YAYLI RONDELA / SPRING WASHER

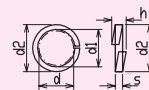

d <sub>max</sub>	d <sub>1</sub>	d <sub>2</sub>	d	s
8.3	16.2	24.4	16	3.5



# Ters Enjeksiyon Kalıp Seti Kuyruklu 446 Serisi

## Reverse Injection Mold Base 446 Series with Locating Pillar

tek  
446

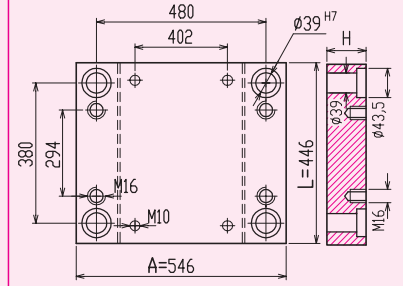
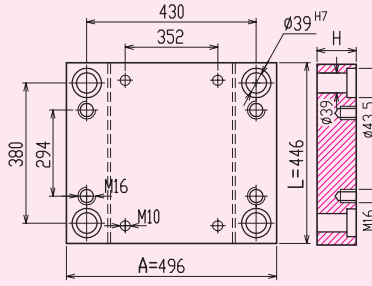
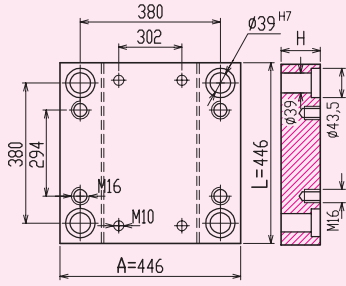

Plakalar / Plates	H	TEK4444	TEK4944	TEK5444
<b>H1-H2</b> 	37			
	47			
	57			
	67			
	77			
	87			
	97			
	107			
<b>H6</b> 	37			
	47			
	57			
	67			
	77			
	87			
<b>H4</b> 	37			
	47			
	57			
	67			
<b>H3</b> 	77			
	87			
	97			
	107			
	117			
<b>H5-H9</b> 	37			
	47			
	57			
<b>H7</b> 	22			
	27			
<b>H8</b> 	27			



# Ters Enjeksiyon Kalıp Seti Kuyruklu 446 Serisi

## Reverse Injection Mold Base 446 Series with Locating Pillar

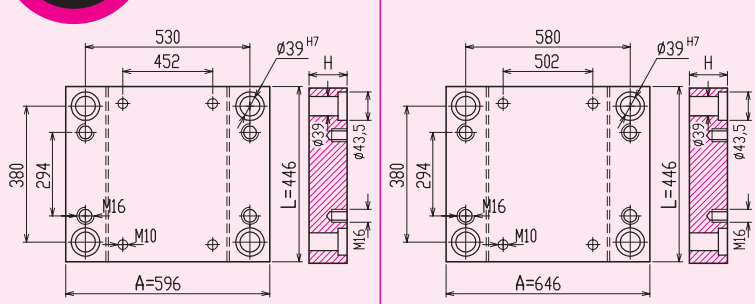

TEK5944

TEK6444

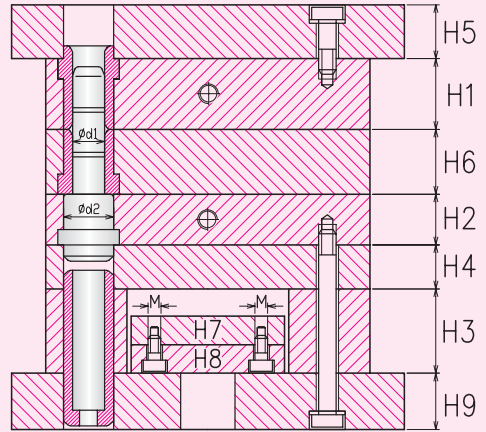
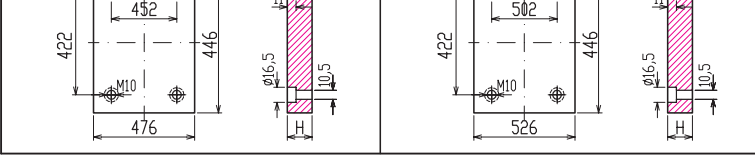
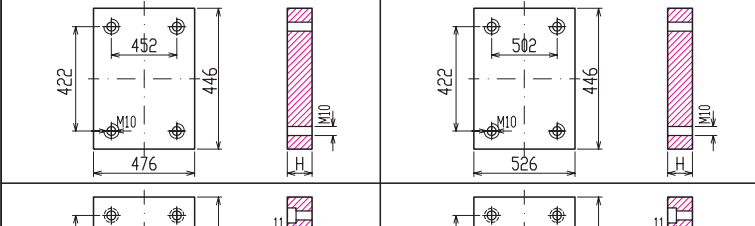
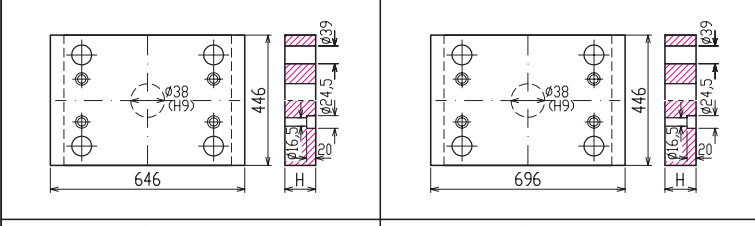
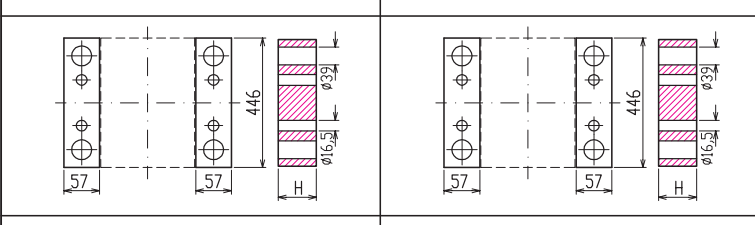
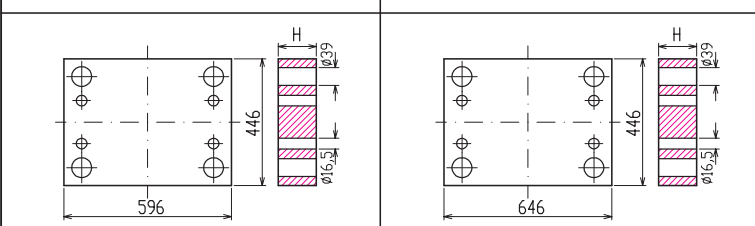
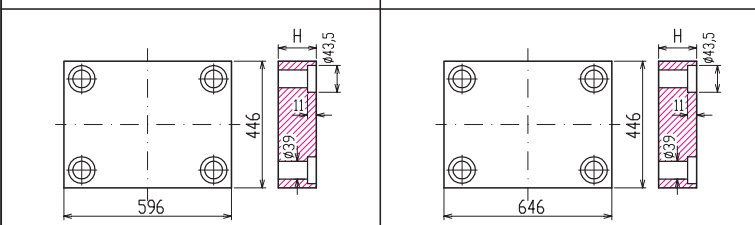
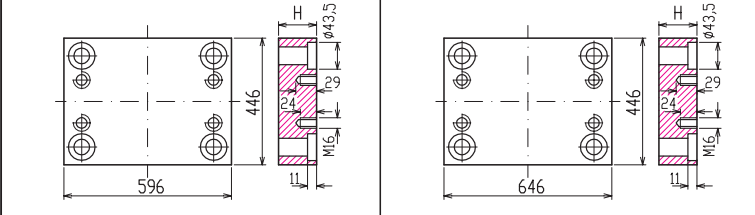

### KOLONLAR / PILLARS

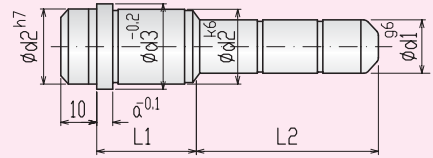

K S K K				L2											
d1	d2	d3	a	L1	36	46	56	66	76	86	96	106	116	126	136
30	39	43	10												

### BURÇLAR / GUIDE BUSHES

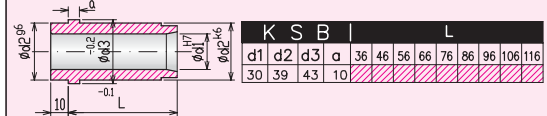

K S B				L								
d1	d2	d3	a	36	46	56	66	76	86	96	106	116
30	39	43	10									

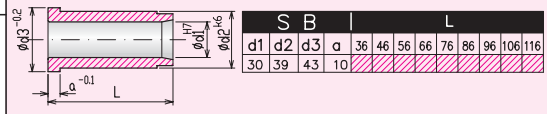

S B				L								
d1	d2	d3	a	36	46	56	66	76	86	96	106	116
30	39	43	10									

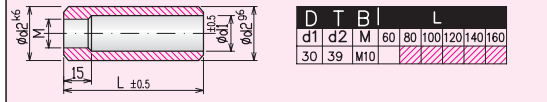

D T B				L				
d1	d2	M	a	80	100	120	140	160
30	39	M10						

### ÇİVATALAR / SOCKET CAP SCREWS

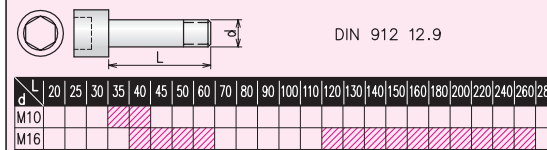

d	L	20	25	30	35	40	45	50	60	70	80	90	100	110	120	130	140	150	160	180	200	220	240	260	280	
M10																										
M16																										

### YAYLI RONDELA / SPRING WASHER

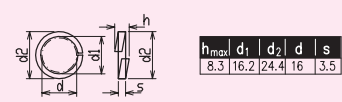

$h_{max}$	d1	d2	d	s
8.3	16.2	24.4	16	3.5



# Ters Enjeksiyon Kalıp Seti Kuyruklu 496 Serisi

## Reverse Injection Mold Base 496 Series with Locating Pillar

tek  
496

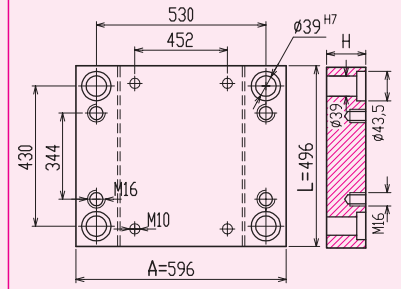
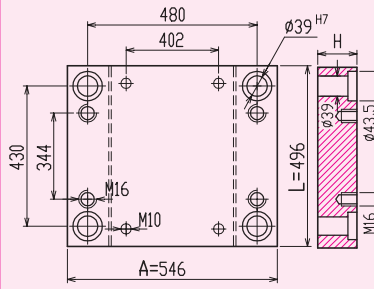
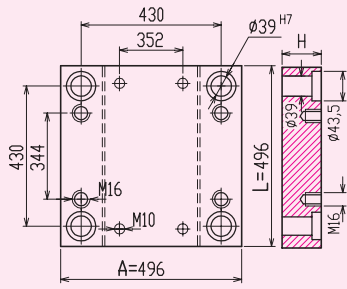

Plakalar / Plates	H	TEK4949	TEK5449	TEK5949
<b>H1-H2</b> 	37			
	47			
	57			
	67			
	77			
	87			
	97			
<b>H6</b> 	37			
	47			
	57			
	67			
	77			
<b>H4</b> 	37			
	47			
	57			
	67			
<b>H3</b> 	77			
	87			
	97			
	107			
	117			
<b>H5-H9</b> 	37			
	47			
	57			
<b>H7</b> 	22			
	27			
<b>H8</b> 	27			



# Ters Enjeksiyon Kalıp Seti Kuyruklu 496 Serisi

## Reverse Injection Mold Base 496 Series with Locating Pillar

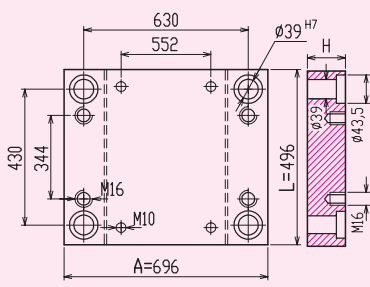
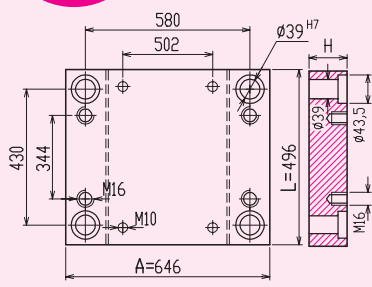

TEK6449

TEK6949

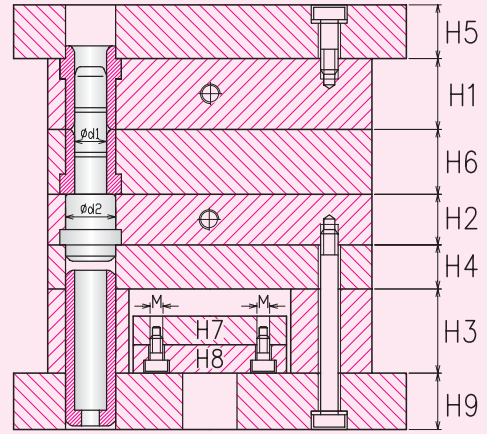
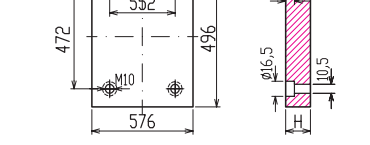
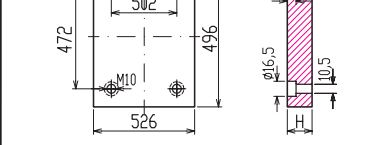
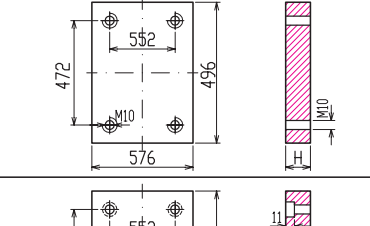
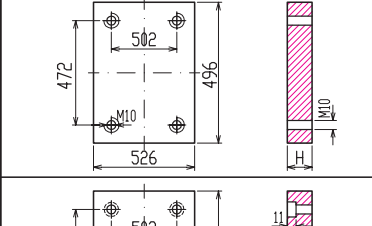
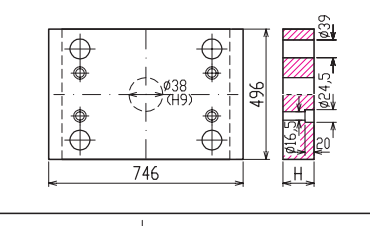
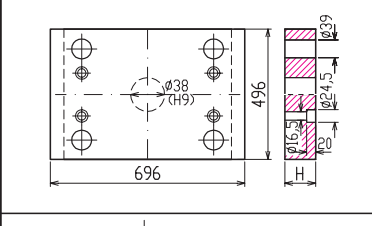
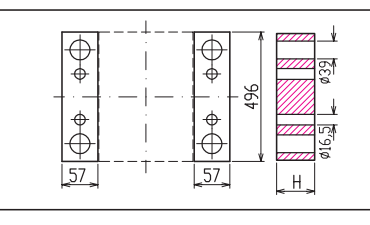
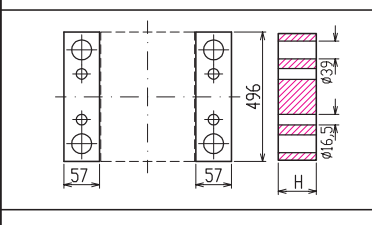
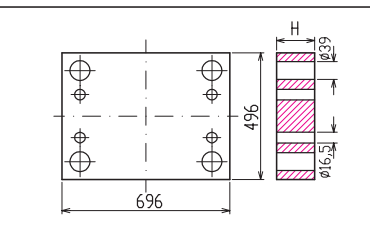
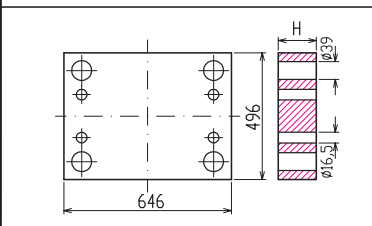
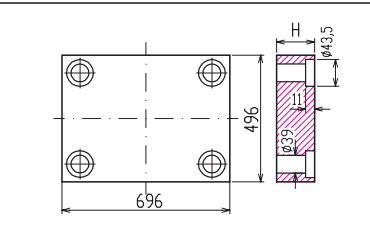
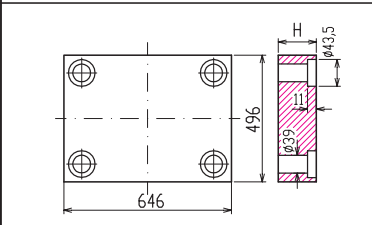
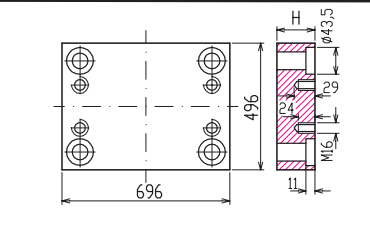
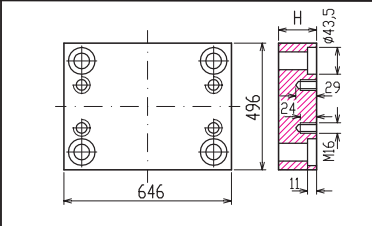

KOLONLAR / PILLARS

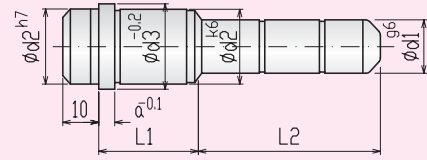

K S K K				L2											
d1	d2	d3	a	L1	36	46	56	66	76	86	96	106	116	126	136
30	39	43	10	36	46	56	66	76	86	96	106	116	126	136	

BURÇLAR / GUIDE BUSHES

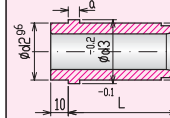

K S B				L								
d1	d2	d3	a	36	46	56	66	76	86	96	106	116
30	39	43	10									

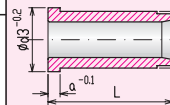

S B				L								
d1	d2	d3	a	36	46	56	66	76	86	96	106	116
30	39	43	10									

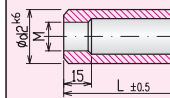

D T B				L				
d1	d2	M	a	80	100	120	140	160
30	39	M10						

ÇİVATALAR / SOCKET CAP SCREWS

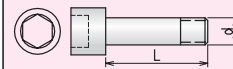

DIN 912 12.9

d	L	20	25	30	35	40	45	50	60	70	80	90	100	110	120	130	140	150	160	180	200	220	240	260	280
M10																									
M16																									

YAYLI RONDELA / SPRING WASHER

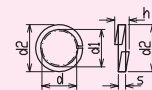

$h_{max}$	d1	d2	d	s
8.3	16.2	24.4	16	3.5



# Ters Enjeksiyon Kalıp Seti Kuyruklu 546 Serisi

## Reverse Injection Mold Base 546 Series with Locating Pillar

tek  
546

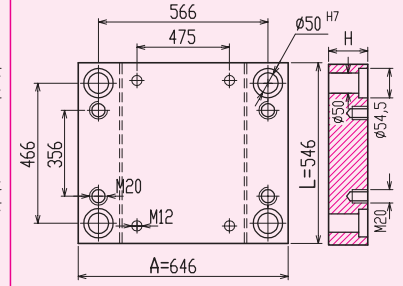
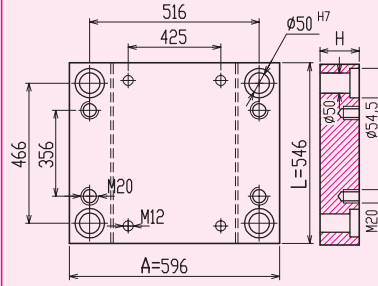
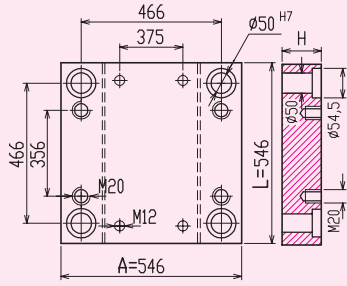

Plakalar / Plates	H	TEK5454	TEK5954	TEK6454
<b>H1-H2</b> 	47			
	57			
	67			
	77			
	87			
	97			
	107			
<b>H6</b> 	47			
	57			
	67			
	77			
	87			
<b>H4</b> 	47			
	57			
	67			
	77			
<b>H3</b> 	77			
	87			
	97			
	107			
	117			
	127			
<b>H5-H9</b> 	47			
	57			
	67			
<b>H7</b> 	22			
	27			
<b>H8</b> 	27			
	37			





# Ters Enjeksiyon Kalıp Seti Kuyruklu 596 Serisi

## Reverse Injection Mold Base 596 Series with Locating Pillar

tek  
596

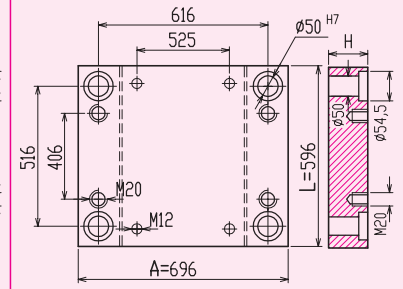
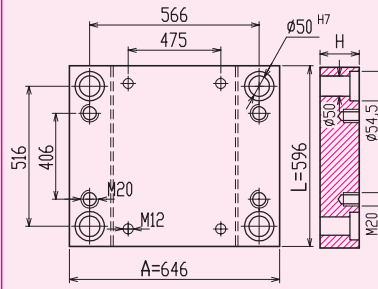
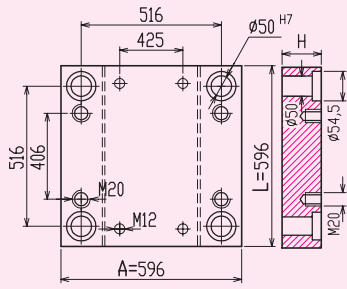

Plakalar / Plates	H	TEK5959	TEK6459	TEK6959
<b>H1-H2</b> 	47			
	57			
	67			
	77			
	87			
	97			
	107			
	117			
<b>H6</b> 	47			
	57			
	67			
	77			
	87			
	97			
<b>H4</b> 	47			
	57			
	67			
	77			
<b>H3</b> 	77			
	87			
	97			
	107			
	117			
	127			
<b>H5-H9</b> 	47			
	57			
	67			
<b>H7</b> 	22			
	27			
<b>H8</b> 	27			
	37			





# Ters Enjeksiyon Kalıp Seti Kuyruklu 596 Serisi

## Reverse Injection Mold Base 596 Series with Locating Pillar

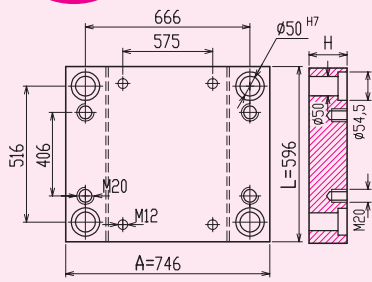

**TEK7459**

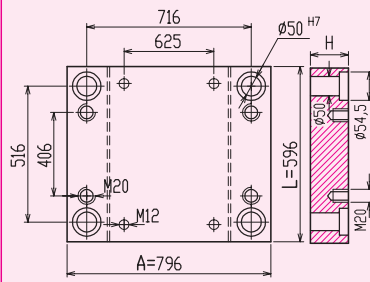

**TEK7959**

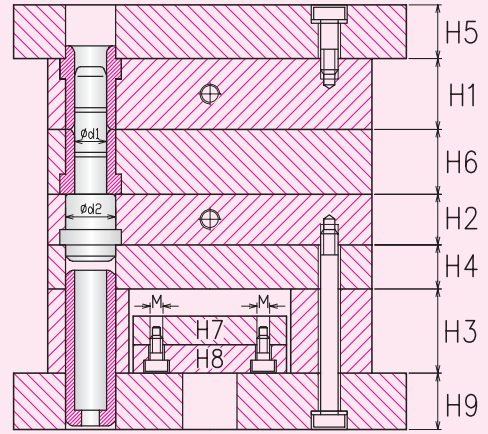
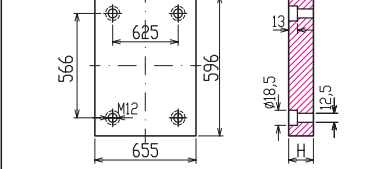
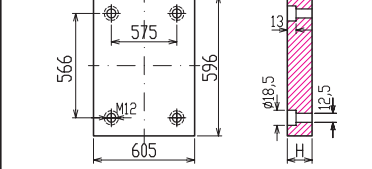
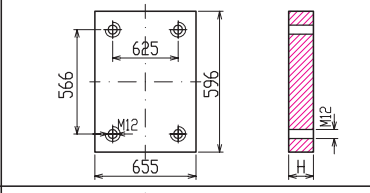
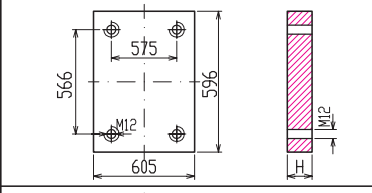
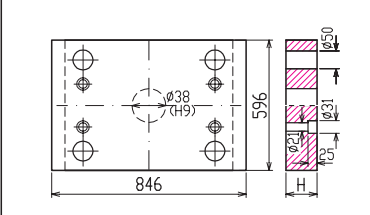
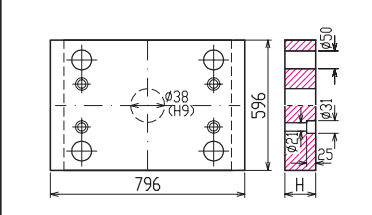
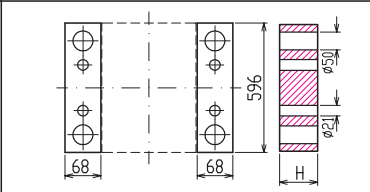
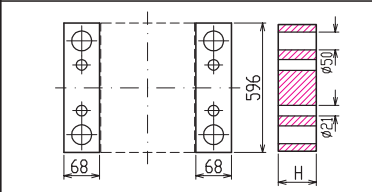
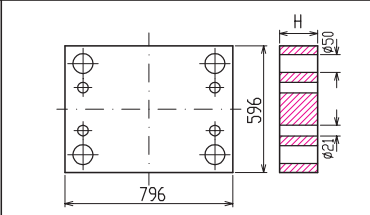
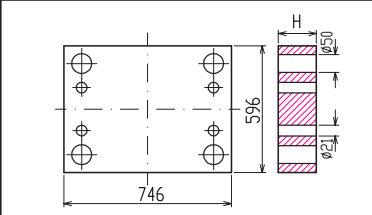
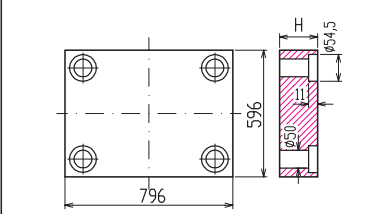
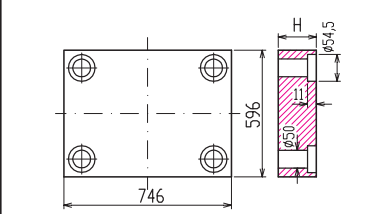
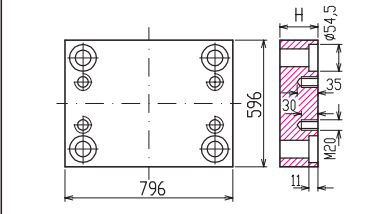
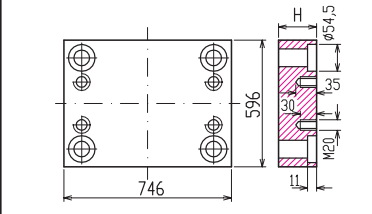

**KOLONLAR / PILLARS**

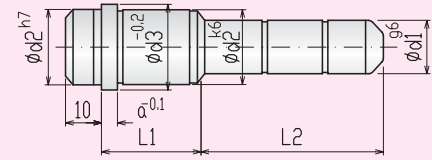

K S K K				L2												
d1	d2	d3	a	L1	46	56	66	76	86	96	106	116	126	136	146	156
40	50	54	10	46	56	66	76	86	96	106	116	126	136	146	156	

STOKLARDA MEVCUT DEĞİLDİR  
ÖZEL OLARAK İMAL EDİLİR  
(NOT IN STOCK CUSTOM BUILD)

**BURÇLAR / GUIDE BUSHES**

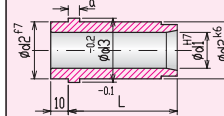

K S B				L											
d1	d2	d3	a	46	56	66	76	86	96	106	116	126			
40	50	54	10	46	56	66	76	86	96	106	116	126			

ÖZEL OLARAK İMAL EDİLİR  
(CUSTOM BUILD)

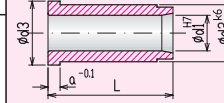

S B				L											
d1	d2	d3	a	46	56	66	76	86	96	106	116	126			
40	50	54	10	46	56	66	76	86	96	106	116	126			

ÖZEL OLARAK İMAL EDİLİR  
(CUSTOM BUILD)

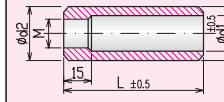

D T B I				L				
d1	d2	M	a	100	120	140	160	180
40	50	M12		100	120	140	160	180

ÖZEL OLARAK İMAL EDİLİR  
(CUSTOM BUILD)

**ÇİVATALAR / SOCKET CAP SCREWS**

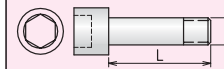

DIN 912 12.9

d	L	25	30	35	40	45	50	60	70	80	90	100	110	120	130	140	150	160	180	200	220	240	260	280	300
M12																									
M20																									

**YAYLI RONDELA / SPRING WASHER**

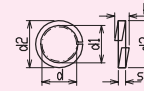

d <sub>max</sub>	d <sub>1</sub>	d <sub>2</sub>	d	s
10.6	20.2	30.6	20	4.5



# Ters Enjeksiyon Kalıp Seti Kuyruklu 646 Serisi

## Reverse Injection Mold Base 646 Series with Locating Pillar

tek  
646

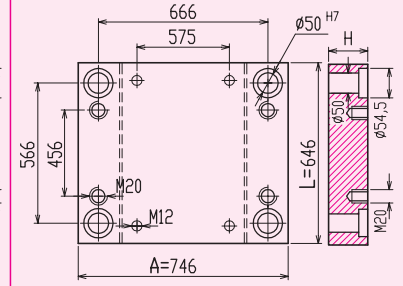
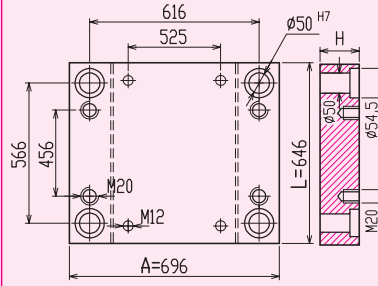
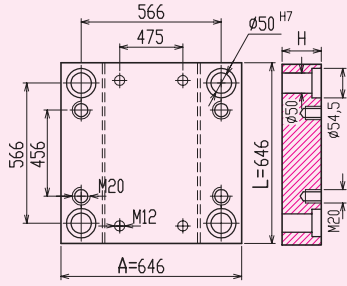

Plakalar / Plates	H	TEK6464	TEK6964	TEK7464
<b>H1-H2</b> 	47			
	57			
	67			
	77			
	87			
	97			
	107			
	117			
<b>H6</b> 	47			
	57			
	67			
	77			
	87			
	97			
<b>H4</b> 	47			
	57			
	67			
	77			
<b>H3</b> 	77			
	87			
	97			
	107			
	117			
	127			
<b>H5-H9</b> 	47			
	57			
	67			
<b>H7</b> 	22			
	27			
<b>H8</b> 	27			
	37			



# Ters Enjeksiyon Kalıp Seti Kuyruklu 646 Serisi

## Reverse Injection Mold Base 646 Series with Locating Pillar

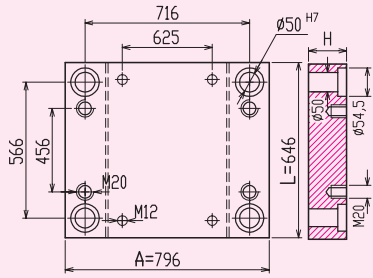

TEK7964

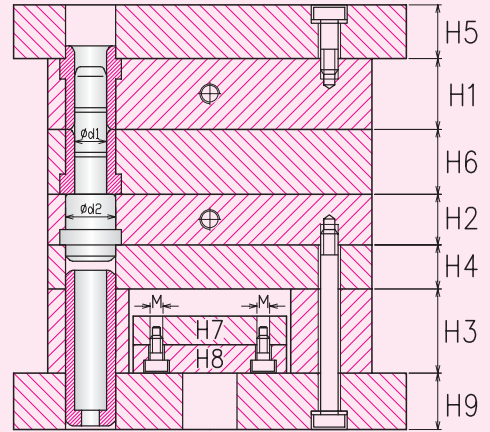
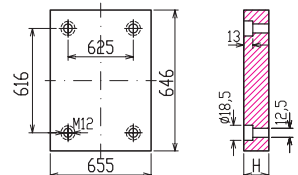
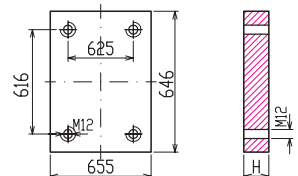
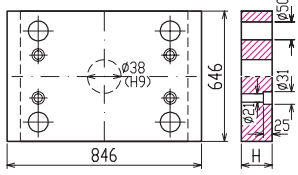
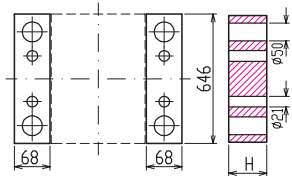
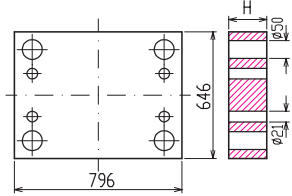
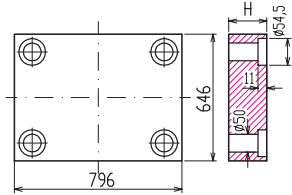
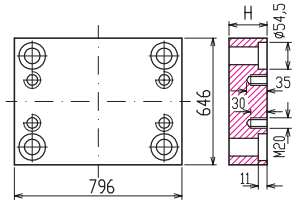

KOLONLAR / PILLARS

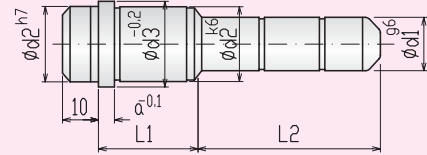

K S K K				L2												
d1	d2	d3	a	L1	46	56	66	76	86	96	106	116	126	136	146	156
40	50	54	10	46	56	66	76	86	96	106	116	126	136	146	156	

STOKLARDA MEVCUT DEĞİLDİR  
ÖZEL OLARAK İMAL EDİLİR  
(NOT IN STOCK CUSTOM BUILD)

BURÇLAR / GUIDE BUSHES

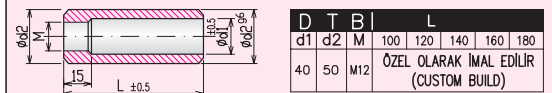
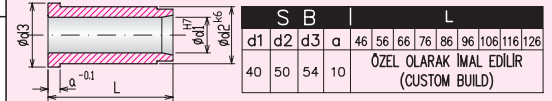
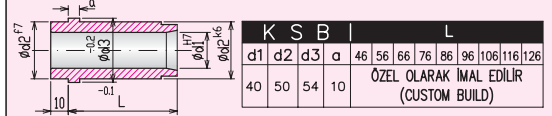

ÇİVATALAR / SOCKET CAP SCREWS

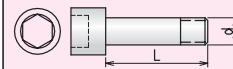

DIN 912 12.9

d	L	25	30	35	40	45	50	60	70	80	90	100	110	120	130	140	150	160	180	200	220	240	260	280	300
M12																									
M20																									

YAYLI RONDELA / SPRING WASHER

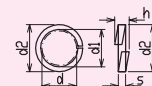

d	h <sub>max</sub>	d1	d2	d	s
10.6	20.2	30.6	20	4.5	



# Ters Enjeksiyon Kalıp Seti Kuyruklu 696 Serisi

## Reverse Injection Mold Base 696 Series with Locating Pillar

tek  
696

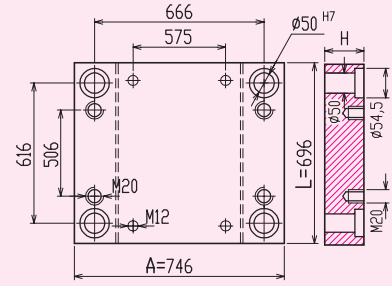
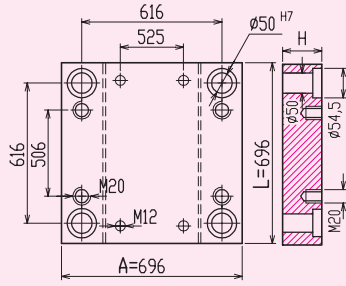

Plakalar / Plates	H	TEK6969	TEK7469
H1-H2 	47		
	57		
	67		
	77		
	87		
	97		
	107		
	117		
H6 	47		
	57		
	67		
	77		
	87		
	97		
H4 	47		
	57		
	67		
	77		
H3 	77		
	87		
	97		
	107		
	117		
	127		
H5-H9 	47		
	57		
	67		
H7 	22		
	27		
H8 	27		
	37		



# Ters Enjeksiyon Kalıp Seti Kuyruklu 696 Serisi

## Reverse Injection Mold Base 696 Series with Locating Pillar

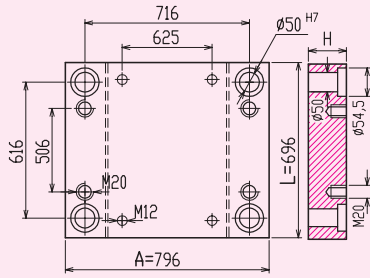

TEK7969

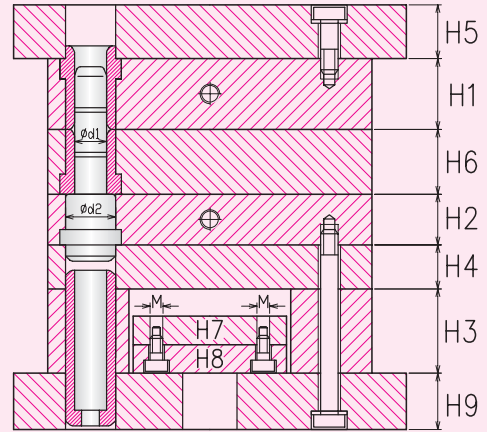
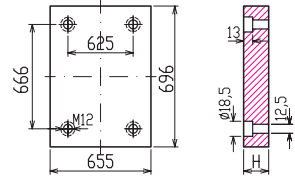
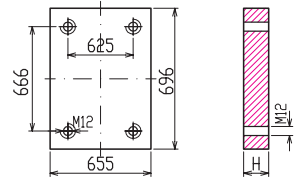
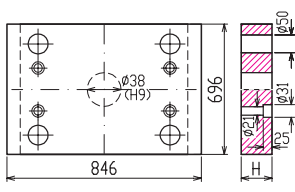
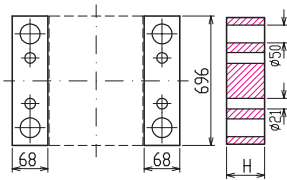
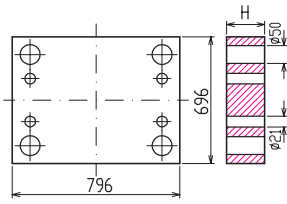
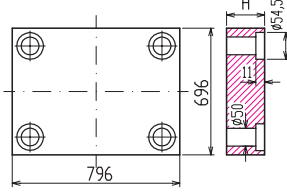
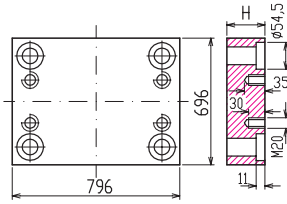

KOLONLAR / PILLARS

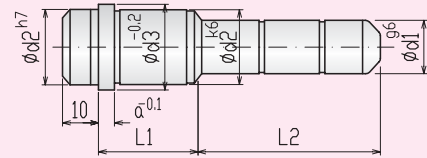

K S K K				L2												
d1	d2	d3	α	L1	46	56	66	76	86	96	106	116	126	136	146	156
40	50	54	10	46	56	66	76	86	96	106	116	126	136	146	156	

STOKLARDA MEVCUT DEĞİLDİR  
ÖZEL OLARAK İMAL EDİLİR  
(NOT IN STOCK CUSTOM BUILD)

BURÇLAR / GUIDE BUSHES

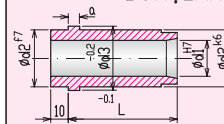

K S B				L											
d1	d2	d3	α	46	56	66	76	86	96	106	116	126			
40	50	54	10	ÖZEL OLARAK İMAL EDİLİR (CUSTOM BUILD)											

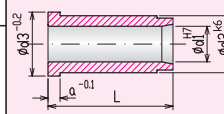

S B				L											
d1	d2	d3	α	46	56	66	76	86	96	106	116	126			
40	50	54	10	ÖZEL OLARAK İMAL EDİLİR (CUSTOM BUILD)											

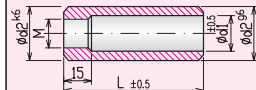

D T B I				L				
d1	d2	M		100	120	140	160	180
40	50	M12		ÖZEL OLARAK İMAL EDİLİR (CUSTOM BUILD)				

ÇİVATALAR / SOCKET CAP SCREWS

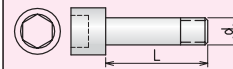

DIN 912 12.9

d	L	25	30	35	40	45	50	60	70	80	90	100	110	120	130	140	150	160	180	200	220	240	260	280	300
M12																									
M20																									

YAYLI RONDELA / SPRING WASHER

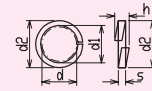

h <sub>max</sub>	d1	d2	d	s
10.6	20.2	30.6	20	4.5



## Pres Kalıp Setleri Katalog Okuma Kılavuzu

### PRES KALIP SETİ TİPLERİ

PD : DÖRT KOLONLU PRES KALIP SETİ  
PÇ : ÇAPRAZ KOLONLU PRES KALIP SETİ  
PĀ : ĀRKADAN KOLONLU PRES KALIP SETİ  
PO : ORTADAN KOLONLU PRES KALIP SETİ

PDB : DÖRT KOLONLU BİLYALI PRES KALIP SETİ  
PÇB : ÇAPRAZ KOLONLU BİLYALI PRES KALIP SETİ  
PĀB : ĀRKADAN KOLONLU BİLYALI PRES KALIP SETİ  
POB : ORTADAN KOLONLU BİLYALI PRES KALIP SETİ

### PLAKA KODLAMASI ÖRNEĞİ :

#### PRES KALIP SETİ TİPİ

(PD/PDB/PÇ/PÇB/PA/PĀB/PO/POB)  
PLAKA ÖLÇÜLERİ (A) A=196  
PLAKA ÖLÇÜLERİ (B) B=346  
PLAKA İSMİ (E/F/C)  
KALINLIK H=37

PO 19 34 E 037

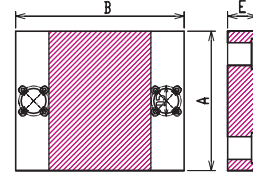

Yukarıda E plakası örneklendirilerek bir plakanın nasıl kodlanacağı anlatılmaktadır. "PO" ifadesi "PRES KALIP SETİ TİPLERİ" başlığı altında belirtildiği üzere "ORTADAN KOLONLU PRES KALIP SETİ" ni temsil etmektedir. 19 34 ; plaka boyutlarının standart 196 x 346 olduğunu anlatmaktadır. E ; E plakasının ifadesi etmektedir. 037 ise plaka kalınlığını göstermektedir. Benzer şekilde kalıp seti içindeki tüm plakalar kodlanarak kalıp seti siparişi verilir. Bunun bir örneği aşağıda sunulmaktadır.

### SET TANIMLAMASI ÖRNEĞİ :

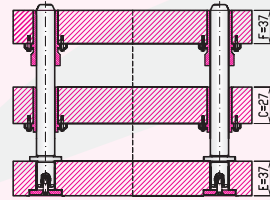

Plaka	Kodlama	Adet
E	PO 19 34 E 037	1
C	PO 19 34 C 027	1
F	P O 19 34 F 037	1
OSK	OSK 25 160 20	2
USB	USB 25 26	2
OSB	OSB 25 36	2

Yukarıdaki örnekte görüleceği üzere plakalar seçildikten sonra istenen serinin standartlarına uygun olarak kolon ve burçlar katalogdaki ilgili sayfalardan seçilir. Kolon ve burç kodlanması örnekte görüldüğü gibi, sipariş için gerekli ölçülerin yanyana yazılması ile yapılır.

## Reading Guide for Die Set Catalog

### TYPE'S OF DIE SETS

PD : FOUR PILLAR DIE SET  
PÇ : DIAGONAL PILLAR DIE SET  
PĀ : HIND PILLAR DIE SET  
PO : MIDDLE PILLAR DIE SET

PDB : FOUR PILLAR BALL DIE SET  
PÇB : DIAGONAL PILLAR BALL DIE SET  
PĀB : HIND PILLAR BALL DIE SET  
POB : MIDDLE PILLAR BALL DIE SET

### PLATE CODING EXAMPLE :

#### TYPE OF DIE SET

(PD/PDB/PÇ/PÇB/PA/PĀB/PO/POB)  
PLATE DIMENSIONS (A) A=196  
PLATE DIMENSIONS (B) B=346  
PLATE NAME (E/F/C)  
THICKNESS H=37

PO 19 34 E 037

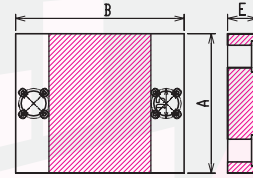

By giving the sample of "E" plate, how to code plate is explained. "PO" Expression resembles the central pillar die set as indicated under the types of die sets title. 19 34 ; tell us that plate dimensions are standart 196 mm by 346 mm. E resembles plate E. 037 shows the plate's thickness. The order for die sets is given with all the plates in the die set coded similarly. There is a sample below ;

### SET DEFINITION SAMPLE :

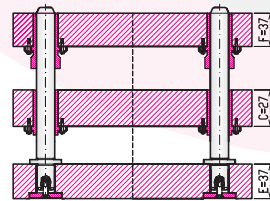

Plate	Coding	Quantity
E	PO 19 34 E 037	1
C	PO 19 34 C 027	1
F	P O 19 34 F 037	1
OSK	OSK 25 160 20	2
USB	USB 25 26	2
OSB	OSB 25 36	2

As seen in the sample above, after the plates are chosen, suitable pillars and bushes for the standarts of desired series, can be chosen from the following pages. Coding for pillars and bushes, as seen in the example, is done by writing the necessary measures for order one after the other.



# Pres Kalıp Setleri Katalog Okuma Kılavuzu

## Reading Guide for Die Sets Catalog

Yan sayfada plaka kodlanması yapılmış olan PO 19 34 (Ortadan kolonlu pres kalıp seti) örneğinin katalogtaki ilgili sayfası aşağıdaki gibidir. Kalıp setlerini oluşturan elemanların nasıl seçileceği ve kodlanacağı aşağıda örneklenerek anlatılmıştır.

Sample page related with the PO 19 34 (Middle Pillar Die Set) inside catalog, whose plate coding is defined on the previous page, is as follows. It is defined that how to chose the items of die set by sampling.



### Pres Kalıp Seti 196 Serisi

#### 196 Series Of Die Set

pks  
196

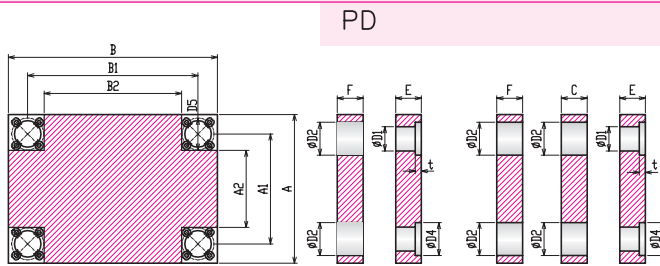
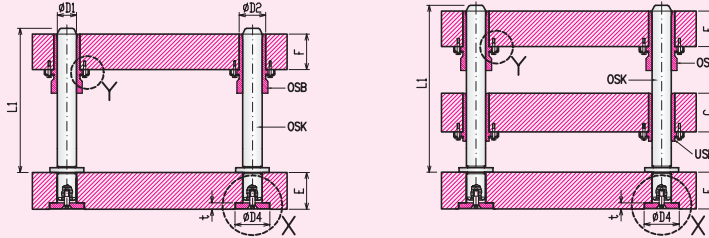

PD

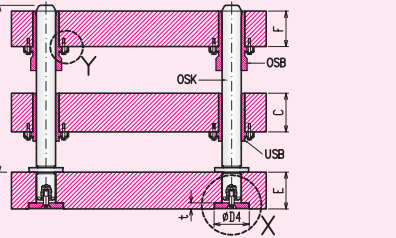

O S K			L1										
D1	D3	M	S	D0	L2	100	125	140	160	180	200	220	240
25	33	M8	5.5	32	20								
					25								
					35								

OSK 25 160 20

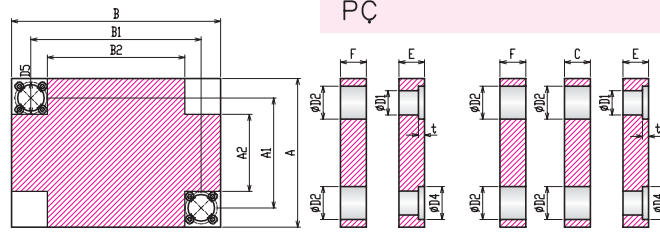

PÇ

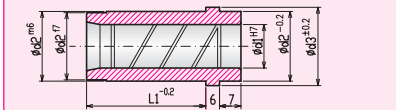

U S B			L1		
d1	d2	d3	26	36	46
25	34	39			

USB 25 26

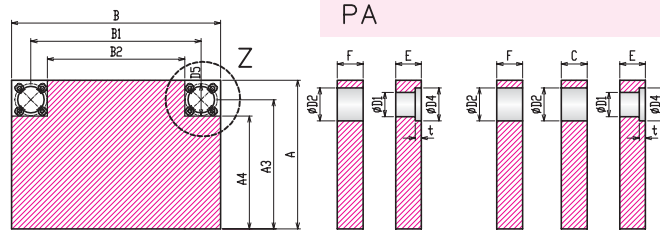

PA

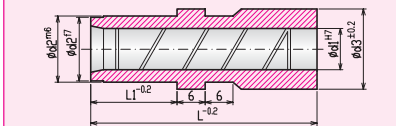

O S B			L1				
d1	d2	d3	L	26	36	46	56
25	34	39	80				

OSB 25 36

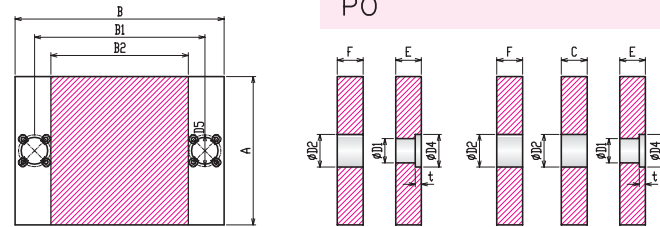

PO

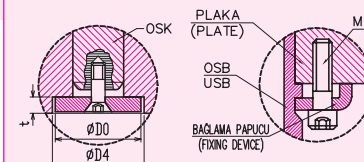

X Detayı/Detail Y Detayı/Detail  
(X Detail) (Y Detail)

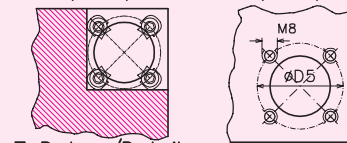

Z Detayı/Detail  
(Z Detail)

KOD	E	F	C	A	B	A1	A2	A3	A4	B1	B2	t	D4	D1	D2	D5
1919				196	196	132	77	164	136	132	77	6.2	34.5	25	34	53
1924	27	27		196	246	132	77	164	136	182	127	6.2	34.5	25	34	53
1929	37		27	196	296	132	77	164	136	232	177	6.2	34.5	25	34	53
1934		37		196	346	132	77	164	136	282	227	6.2	34.5	25	34	53
1939	47			196	396	132	77	164	136	332	277	6.2	34.5	25	34	53

PO 19 34 E 037

PO 19 34 F 037

PO 19 34 C 027

PKS



DKSET  
PRODUCTION TURKEY 2004

XT6483

01

02

03

04

05

06

23XR



# Pres Kalip Seti Die Set

**pks**  
serisi / series

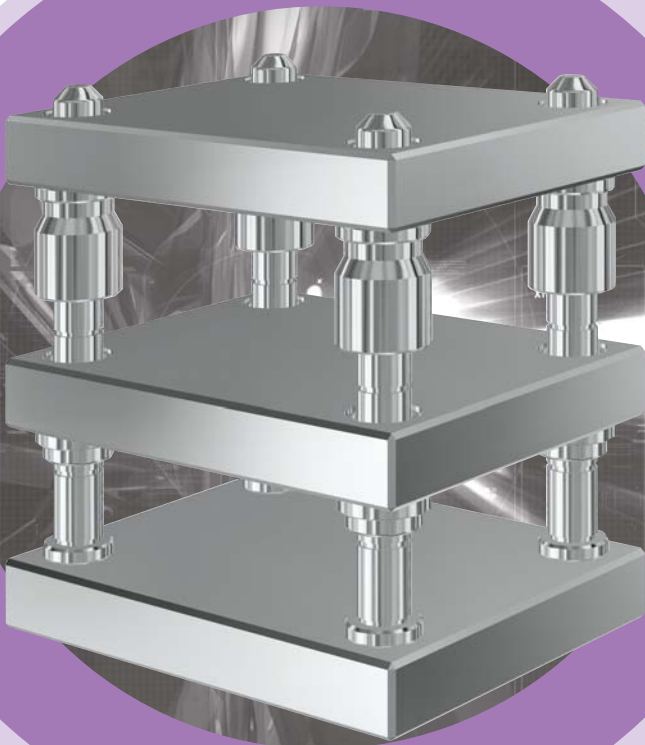

 **OKSET**<sup>®</sup>



# Pres Kalıp Seti 156 Serisi 156 Series of Die Set

pkS  
156

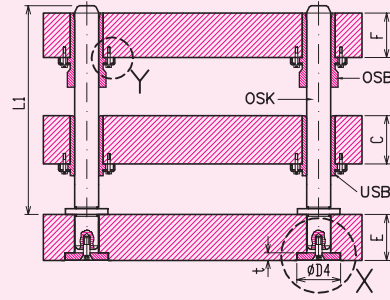
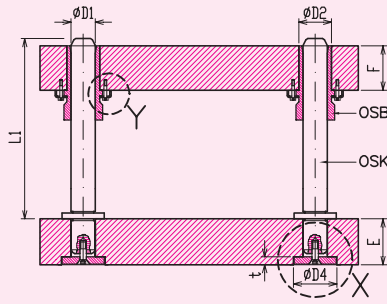

## PD

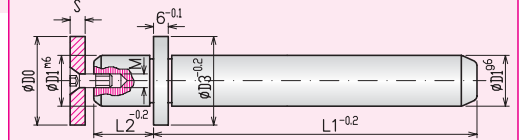
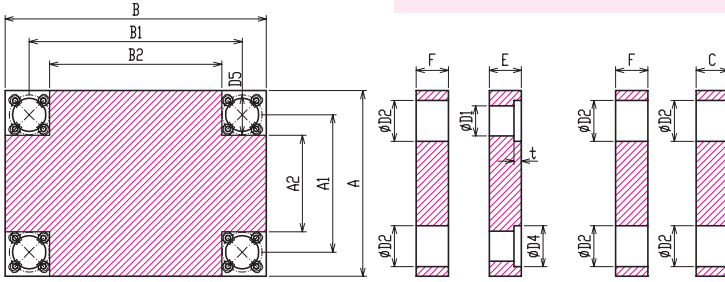

O S K					L1					
D1	D3	M	S	D0	L2	100	125	140	160	180
20	28	M6	5.5	25	20					
					25					
					35					

## PÇ

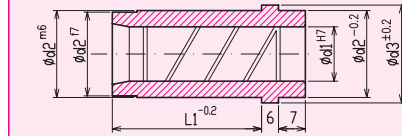
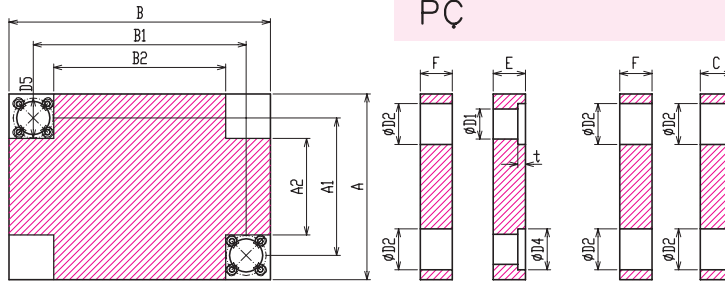

U S B			L1		
d1	d2	d3	26	36	46
20	28	34			

## PA

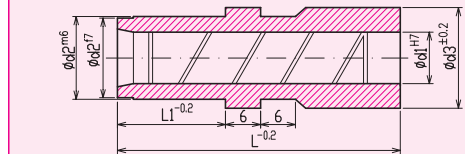
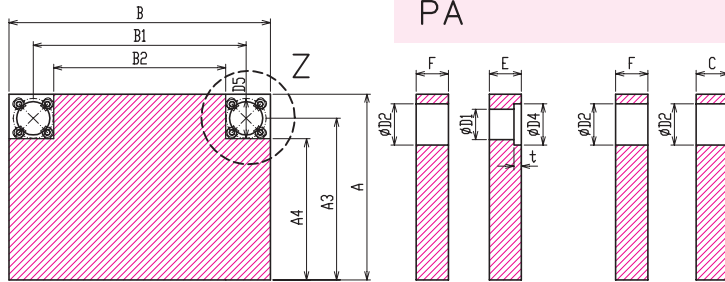

O S B			L1				
d1	d2	d3	L	26	36	46	56
20	28	34	70				

## P0

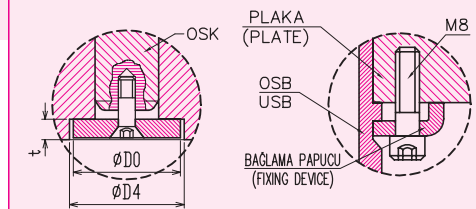
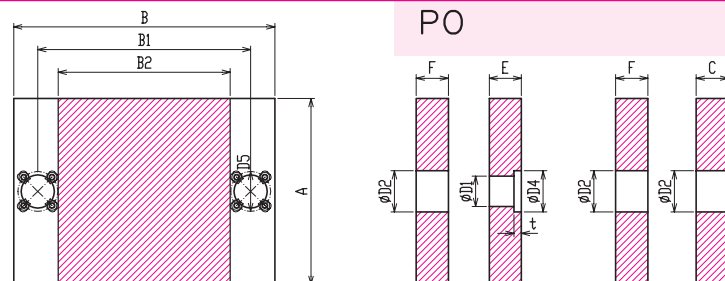

X Detayı/Detail Y Detayı/Detail

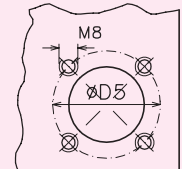
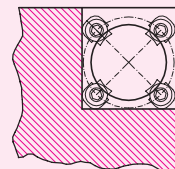

Z Detayı/Detail

KOD	E	F	C	A	B	A1	A2	A3	A4	B1	B2	t	D4	D1	D2	D5
1515	27	27		156	156	100	48	128	102	100	48	6.2	28.5	20	28	48
1519				156	196	100	48	128	102	140	88	6.2	28.5	20	28	48
1524	37	37	27	156	246	100	48	128	102	190	138	6.2	28.5	20	28	48
1529	47			156	296	100	48	128	102	240	188	6.2	28.5	20	28	48



# Pres Kalıp Seti 196 Serisi 196 Series of Die Set

pkS  
196

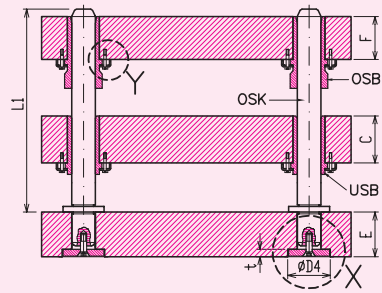
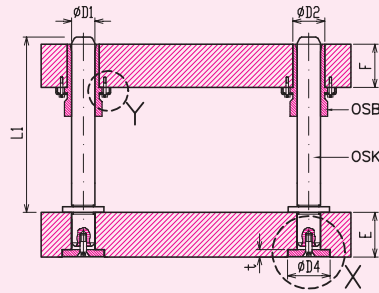

## PD

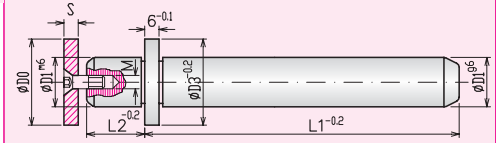
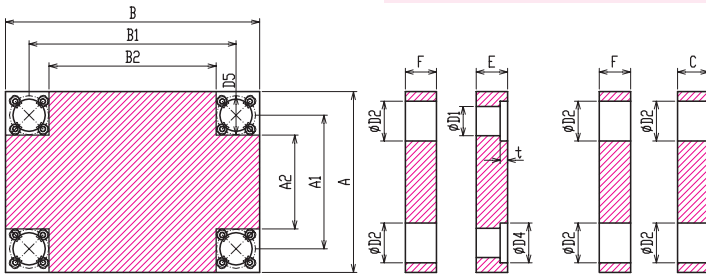

O S K						L1							
D1	D3	M	S	D0	L2	100	125	140	160	180	200	220	240
25	33	MB	5.5	32	20								
					25								
					35								

## PÇ

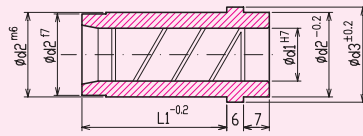
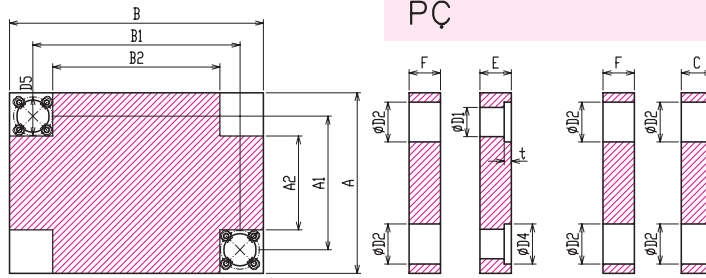

U S B I				L1	
d1	d2	d3	26	36	46
25	34	39			

## PA

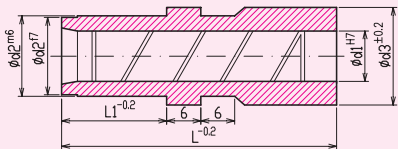
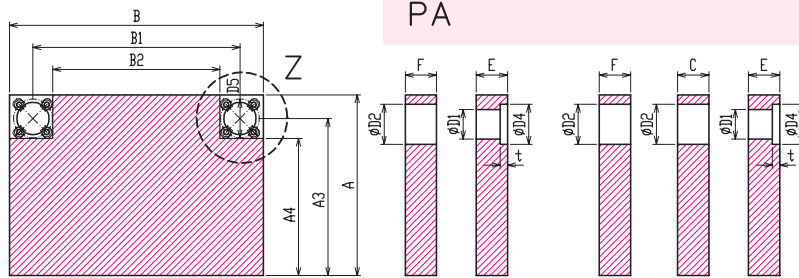

O S B			L1				
d1	d2	d3	L	26	36	46	56
25	34	39	80				

## PO

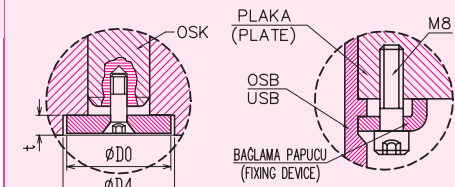
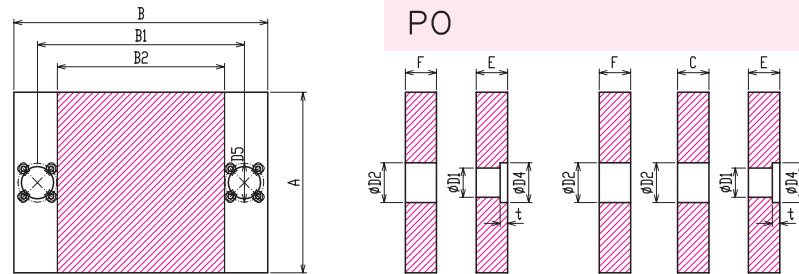

X Detayı/Detail Y Detayı/Detail

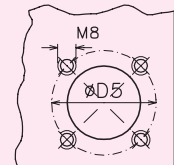
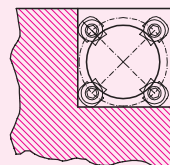

Z Detayı/Detail

KOD	E	F	C	A	B	A1	A2	A3	A4	B1	B2	t	D4	D1	D2	D5
1919				196	196	132	77	164	136	132	77	6.2	34.5	25	34	53
1924	27	27		196	246	132	77	164	136	182	127	6.2	34.5	25	34	53
1929	37		27	196	296	132	77	164	136	232	177	6.2	34.5	25	34	53
1934	47	37		196	346	132	77	164	136	282	227	6.2	34.5	25	34	53
1939				196	396	132	77	164	136	332	277	6.2	34.5	25	34	53



# Pres Kalip Seti 246 Serisi 246 Series of Die Set

pkS  
246

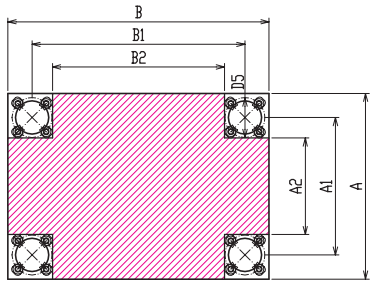
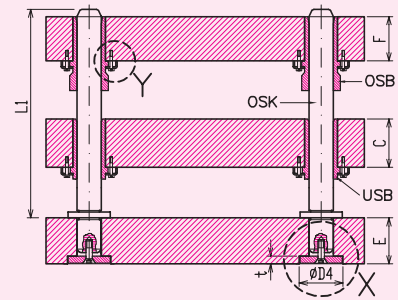
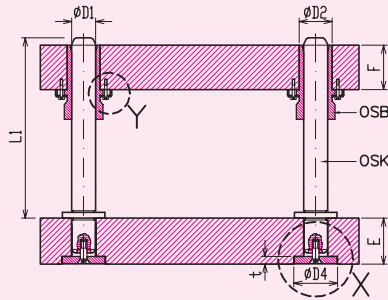

PD

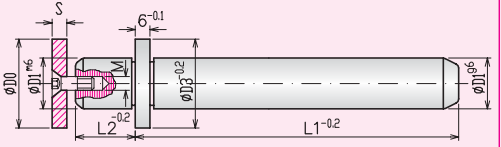
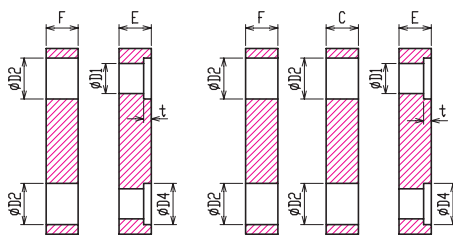

O S K		L1														
D1	D3	M	S	D0	L2	125	140	160	180	200	220	240	260	280	315	355
30	38	M8	7.5	40	28											
					35											
					45											

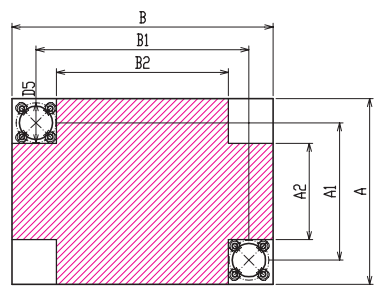

PÇ

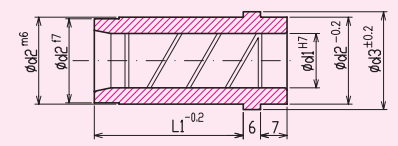
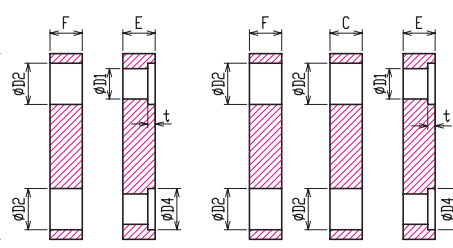

U S B			L1		
d1	d2	d3	26	36	46
30	39	44			

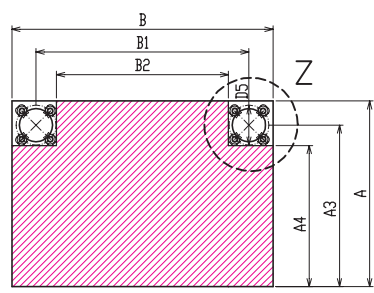

PA

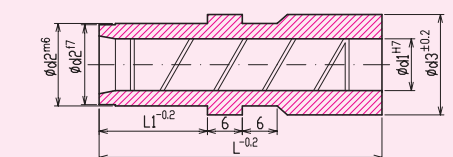
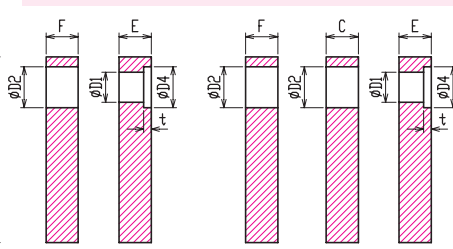

O S B			L1				
d1	d2	d3	L	26	36	46	56
30	39	44	90				

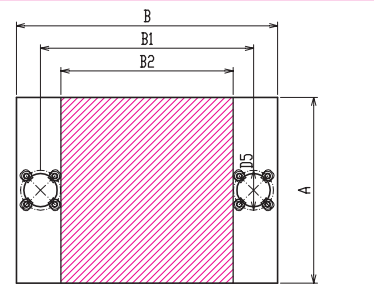

PO

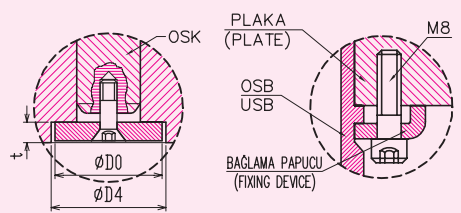
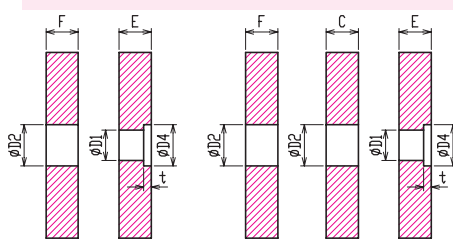

X Detayı/Detail Y Detayı/Detail

KOD	E	F	C	A	B	A1	A2	A3	A4	B1	B2	t	D4	D1	D2	D5
2424	37			246	246	174	115	210	180	174	115	8.2	42	30	39	58
2429		37	27	246	296	174	115	210	180	224	165	8.2	42	30	39	58
2434	47			246	346	174	115	210	180	274	215	8.2	42	30	39	58
2439		47	37	246	396	174	115	210	180	324	265	8.2	42	30	39	58
2444	57			246	446	174	115	210	180	374	315	8.2	42	30	39	58

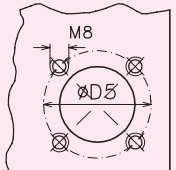
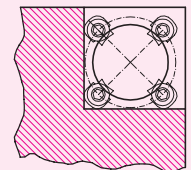

Z Detayı/Detail



# Pres Kalıp Seti 296 Serisi 296 Series of Die Set

pkS  
296

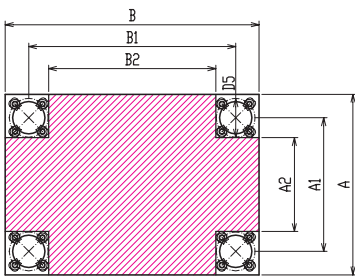
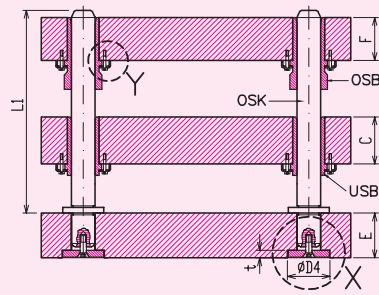
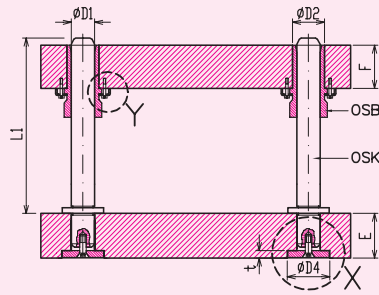

PD

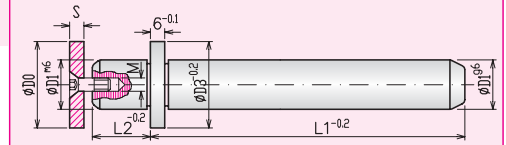
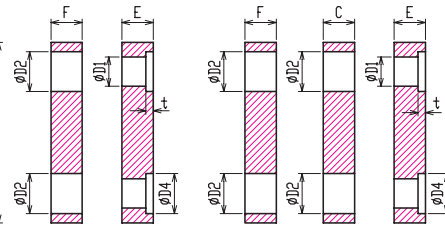

O S K				L1												
D1	D3	M	S	D0	L2	125	140	160	180	200	220	240	260	280	315	355
30	38	M8	7.5	40	28											
					35											
					45											
40	48	M8	9.5	50	25											
					35											
					45											

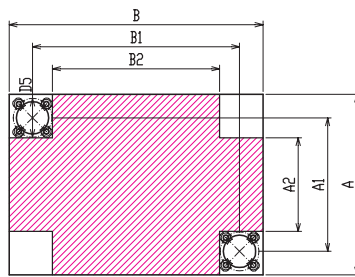

PÇ

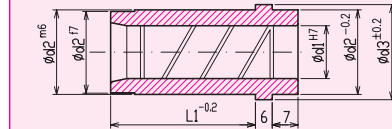
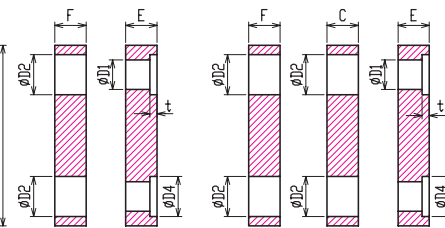

U S B			L1			
d1	d2	d3	L	26	36	46
30	39	44				
40	50	54				

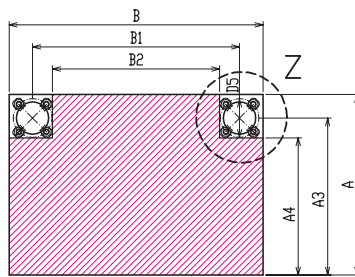

PA

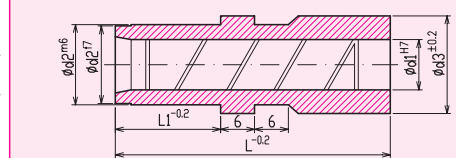
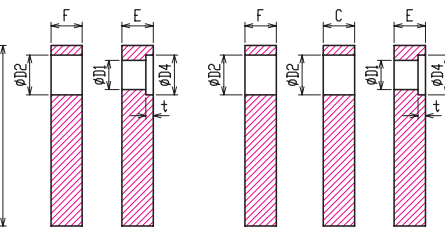

O S B			L1				
d1	d2	d3	L	26	36	46	56
30	39	44	90				
40	50	54	100				

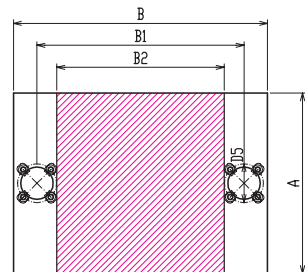

PO

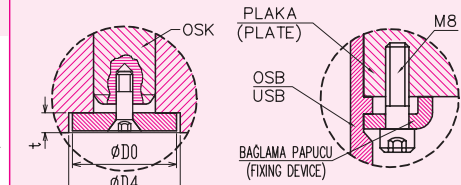
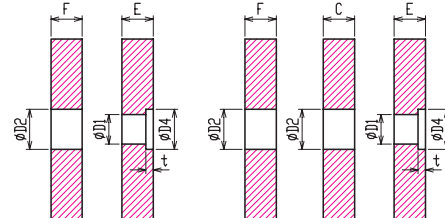

X Detayı/Detail Y Detayı/Detail

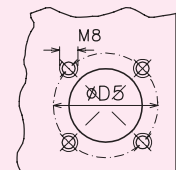
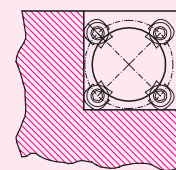

Z Detayı/Detail

KOD	E	F	C	A	B	A1	A2	A3	A4	B1	B2	t	D4	D1	D2	D5
2929				296	296	224	165	260	230	224	165	8.2	42	30	39	58
2934	37	37	37	296	346	224	165	260	230	274	215	8.2	42	30	39	58
2939	47	47	47	296	396	224	165	260	230	324	265	8.2	42	30	39	58
2944	57	57	57	296	446	224	165	260	230	374	315	8.2	42	30	39	58
2949				296	496	212	146	254	221	412	346	10.5	52	40	50	68



# Pres Kalip Seti 346 Serisi 346 Series of Die Set

pkS  
346

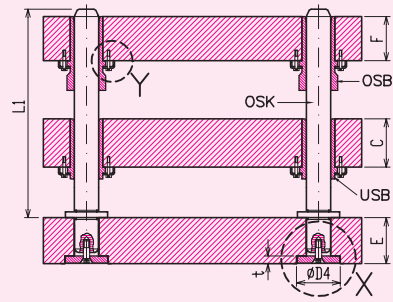
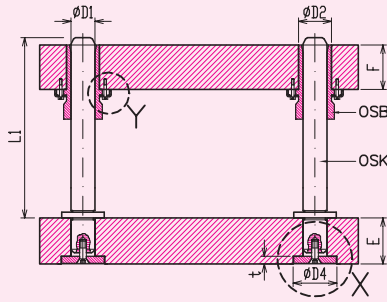

## PD

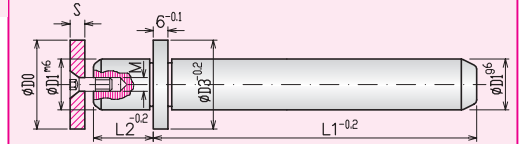
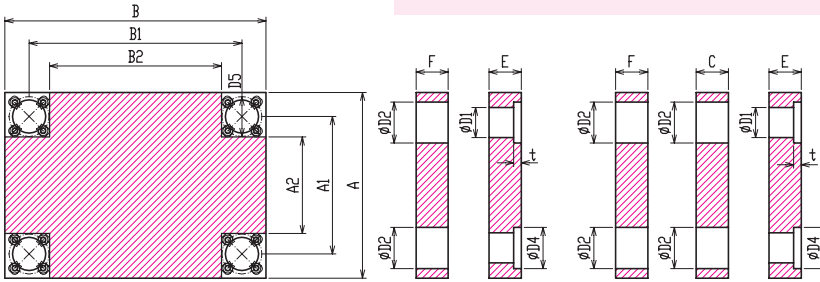

OSK		L1															
D1	D3	M	S	D0	L2	125	140	160	180	200	220	240	260	280	315	355	
30	38	M8	7.5	40	28												
					35												
					45												
40	48	M8	9.5	50	25												
					35												
					45												

## PÇ

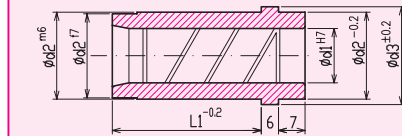
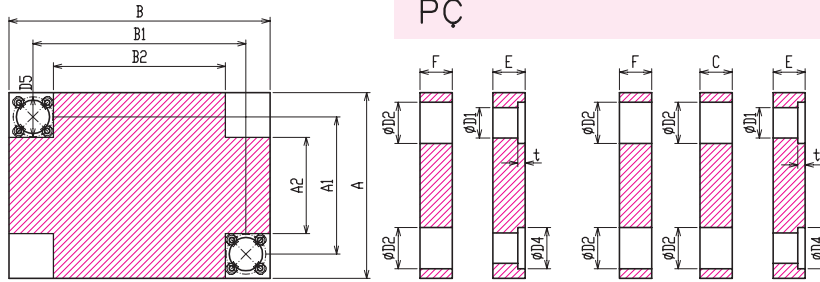

USB		L1			
d1	d2	d3	26	36	46
30	39	44			
40	50	54			

## PA

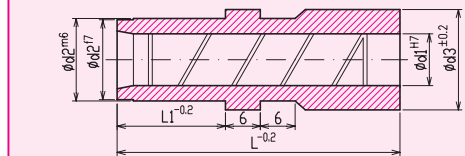
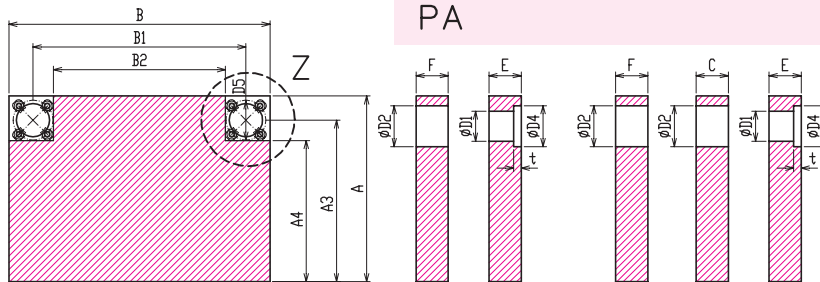

OSB		L1					
d1	d2	d3	L	26	36	46	56
30	39	44	90				
40	50	54	100				

## PO

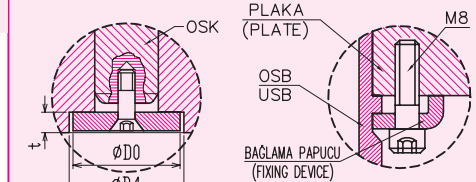
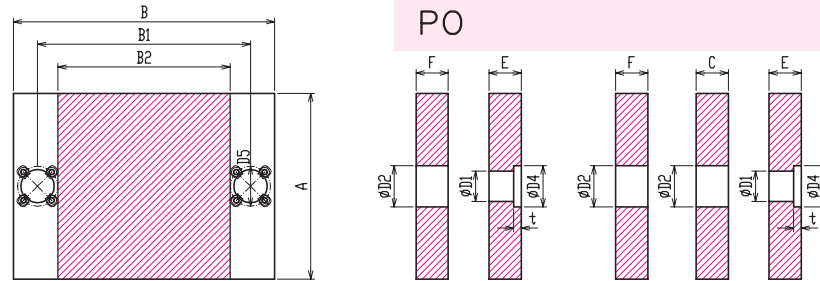

X Detayı/Detail Y Detayı/Detail

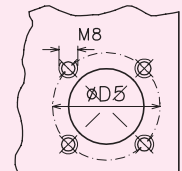
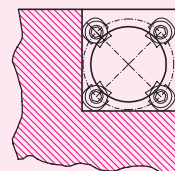

Z Detayı/Detail

KOD	E	F	C	A	B	A1	A2	A3	A4	B1	B2	t	D4	D1	D2	D5
3434	37	37		346	346	274	215	310	280	274	215	8.2	42	30	39	58
3439			37	346	396	274	215	310	280	324	265	8.2	42	30	39	58
3444	47	47		346	446	274	215	310	280	374	315	8.2	42	30	39	58
3449			47	346	496	262	196	304	271	412	346	10.5	52	40	50	68
3454	57	57		346	546	262	196	304	271	462	396	10.5	52	40	50	68



# Pres Kalıp Seti 396 Serisi 396 Series of Die Set

pkS  
396

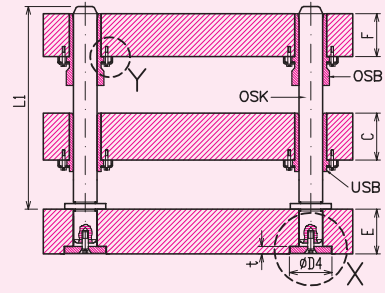
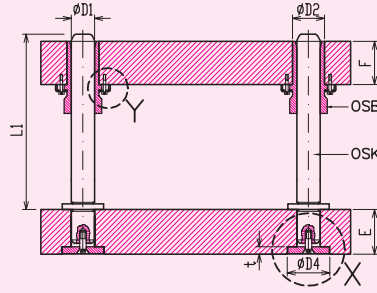

PD

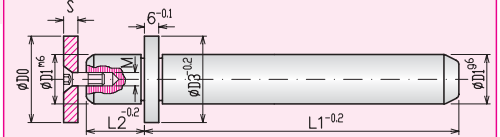
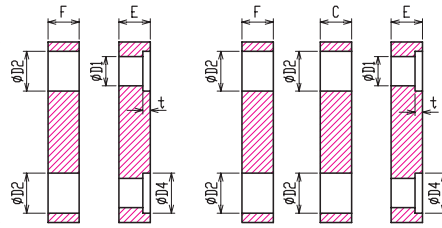
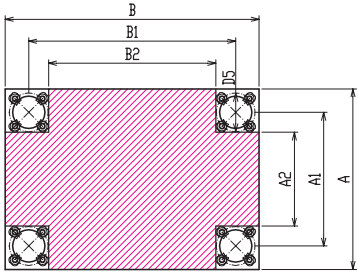

OSK				L1												
D1	D3	M	S	D0	L2	140	160	180	200	220	240	260	280	315	355	400
40	48	M8	9.5	50	35											
					45											
50	58	M10	9.5	60	45											
					55											

PÇ

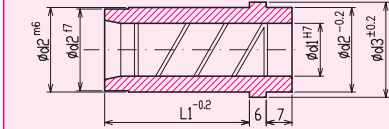
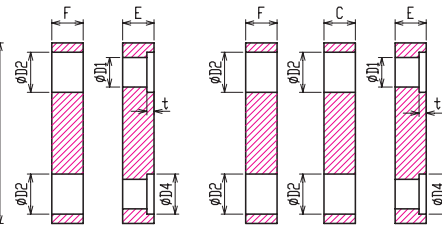
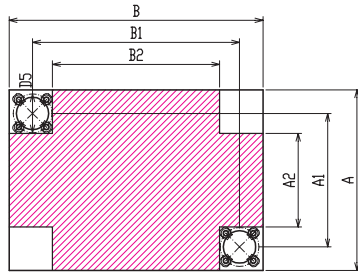

USB			L1		
d1	d2	d3	26	36	46
40	50	54			
50	60	64			

PA

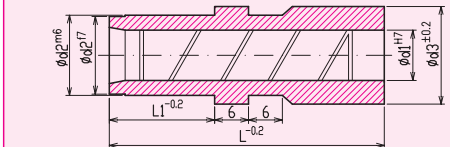
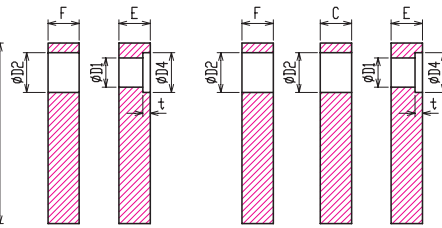
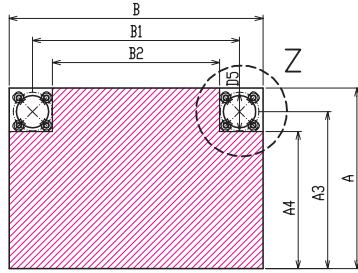

OSB			L1				
d1	d2	d3	L	26	36	46	56
40	50	54	100				
50	60	64	120				

PO

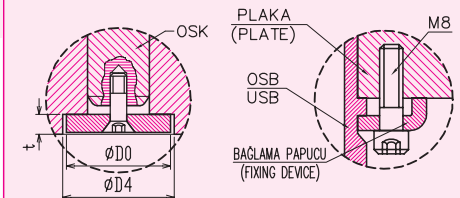
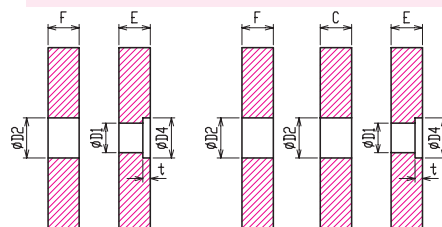
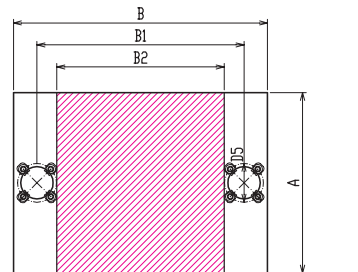

X Detayı/Detail Y Detayı/Detail

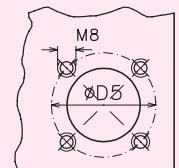
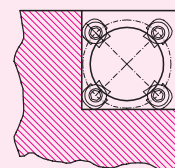

Z Detayı/Detail

KOD	E	F	C	A	B	A1	A2	A3	A4	B1	B2	t	D4	D1	D2	D5
3939				396	396	312	246	354	321	312	246	10.5	52	40	50	68
3944	47	47	37	396	446	312	246	354	321	362	296	10.5	52	40	50	68
3949				396	496	312	246	354	321	412	346	10.5	52	40	50	68
3954	57	57	47	396	546	312	246	354	321	462	396	10.5	52	40	50	68
3959	67		47	396	596	300	227	348	311	500	427	10.5	64	50	60	78



# Pres Kalip Seti 446 Serisi 446 Series of Die Set

pkS  
446

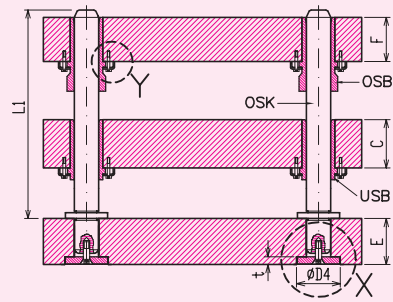
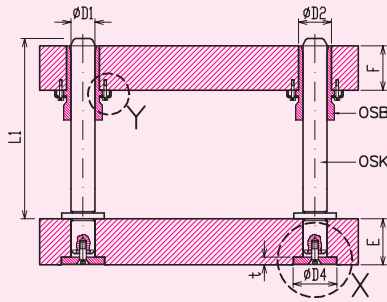

## PD

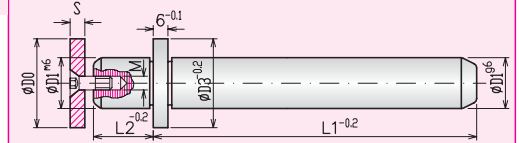
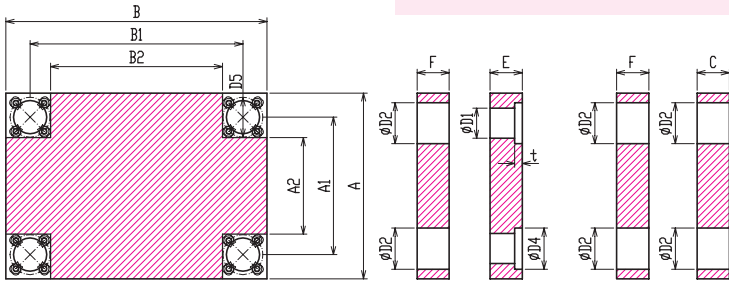

O S K		L1															
D1	D3	M	S	D0	L2	140	160	180	200	220	240	260	280	315	355	400	
40	48	M8	9.5	50	35												
					45												
					35												
50	58	M10	9.5	60	45												
					55												

## PÇ

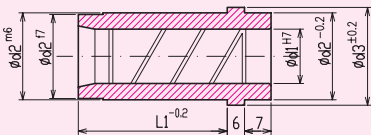
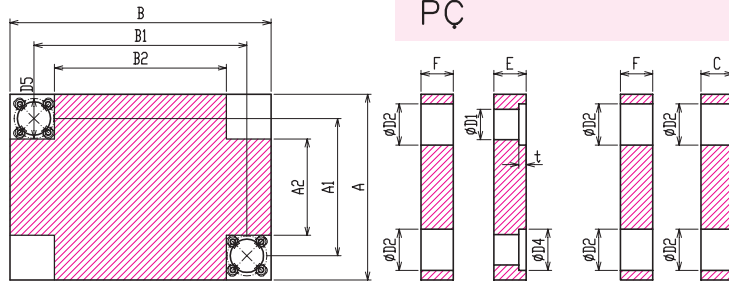

U S B			L1		
d1	d2	d3	26	36	46
40	50	54			
50	60	64			

## PA

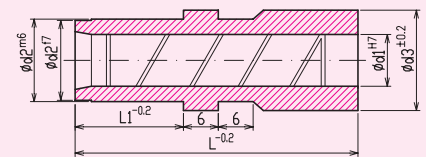
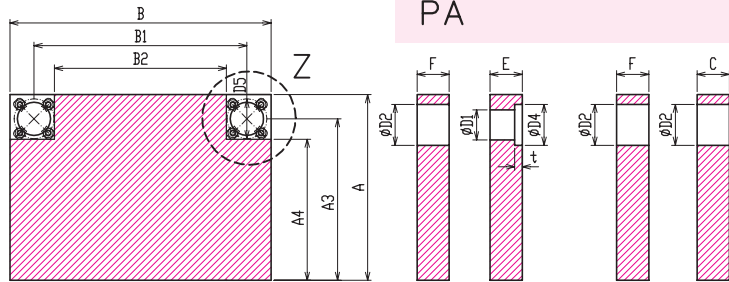

O S B			L1				
d1	d2	d3	L	26	36	46	56
40	50	54	100				
50	60	64	120				

## P0

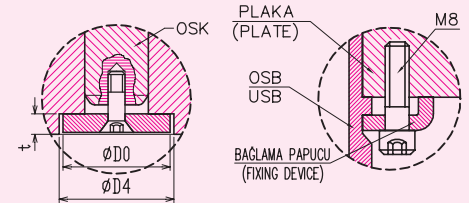
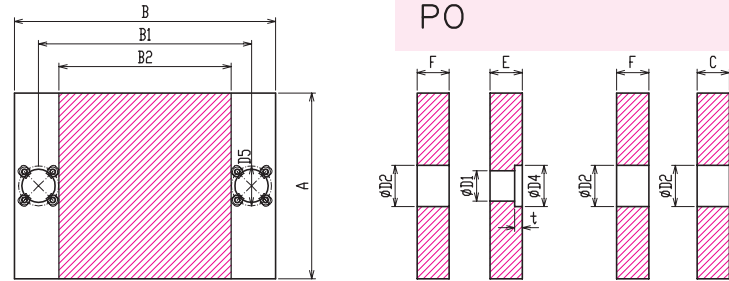

X Detayı/Detail Y Detayı/Detail

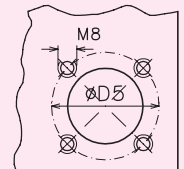
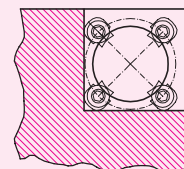

Z Detayı/Detail

KOD	E	F	C	A	B	A1	A2	A3	A4	B1	B2	t	D4	D1	D2	D5
4444	47	47	37	446	446	362	296	404	371	362	296	10.5	52	40	50	68
4449	47	47	37	446	496	362	296	404	371	412	346	10.5	52	40	50	68
4454	57	57	47	446	546	362	296	404	371	462	396	10.5	52	40	50	68
4459	67	67	47	446	596	350	277	398	361	500	427	10.5	64	50	60	78
4464	67	67	47	446	646	350	277	398	361	550	477	10.5	64	50	60	78





# Pres Kalip Seti 496 Serisi 496 Series of Die Set

pkS  
496

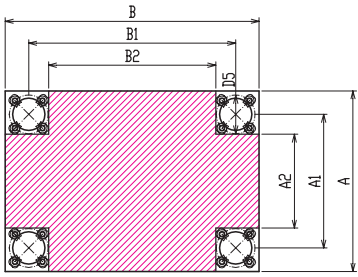
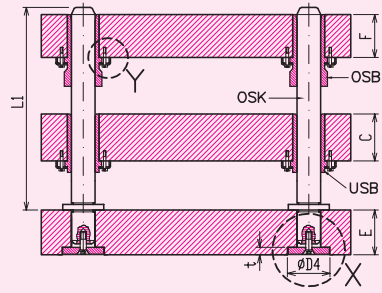
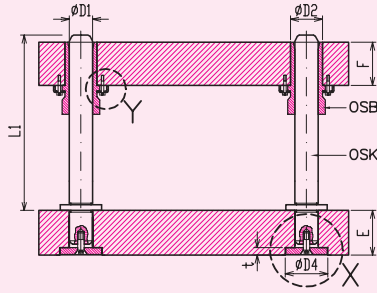

PD

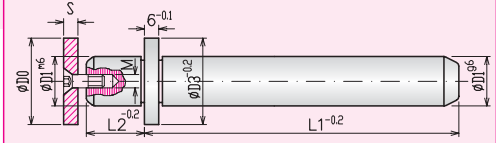
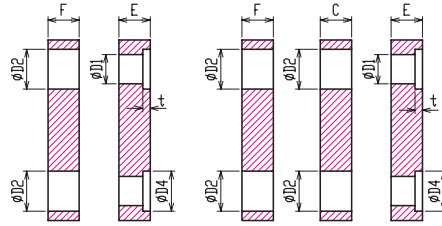

O S K					L1											
D1	D3	M	S	D0	L2	140	160	180	200	220	240	260	280	315	355	400
50	58	M10	9.5	60	35											
					45											
					55											

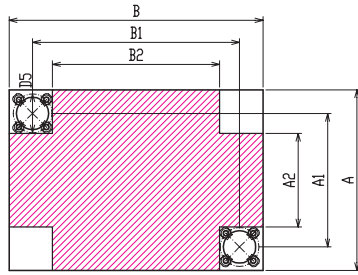

PÇ

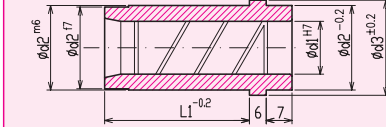
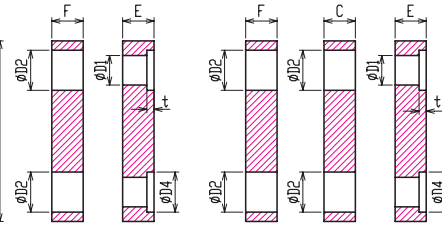

U S B I				L1	
d1	d2	d3	26	36	46
50	60	64			

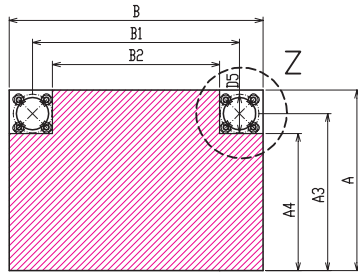

PA

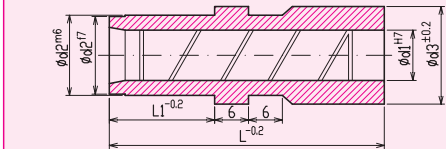
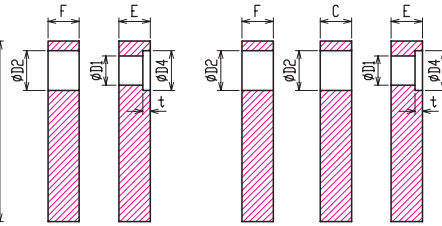

O S B				L1			
d1	d2	d3	L	26	36	46	56
50	60	64	120				

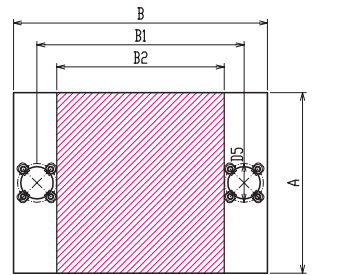

PO

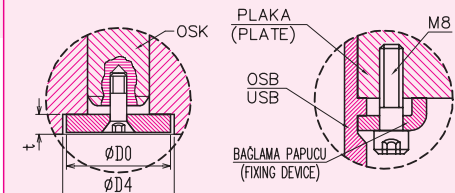
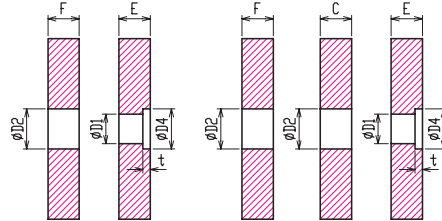

X Detayı/Detail Y Detayı/Detail

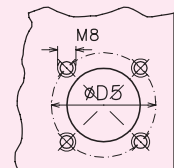
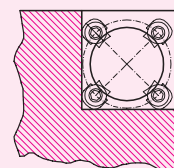

Z Detayı/Detail

KOD	E	F	C	A	B	A1	A2	A3	A4	B1	B2	t	D4	D1	D2	D5
4949	47	47		496	496	400	327	448	411	400	327	10.5	64	50	60	78
4954				496	546	400	327	448	411	450	377	10.5	64	50	60	78
4959	57	57	47	496	596	400	327	448	411	500	427	10.5	64	50	60	78
4964				496	646	400	327	448	411	550	477	10.5	64	50	60	78
4969	67	67		496	696	400	327	448	411	600	527	10.5	64	50	60	78

PKS





# Pres Kalıp Seti 596 Serisi 596 Series of Die Set

pkS  
596

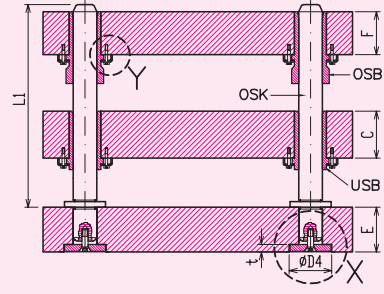
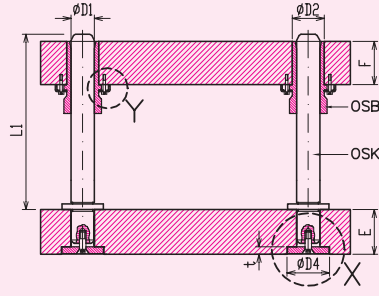

PD

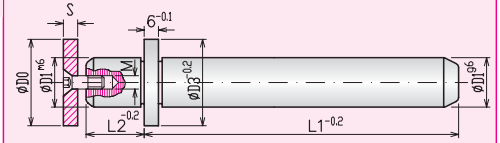
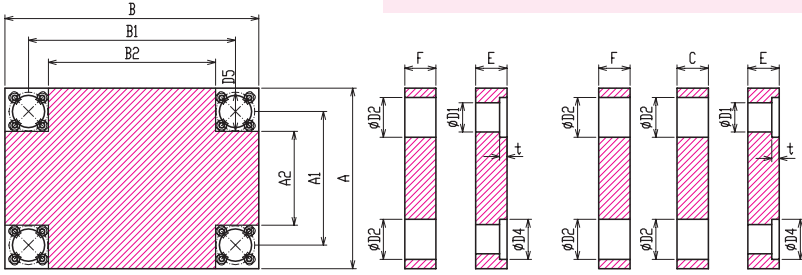

O S K					L1	
D1	D3	M	S	D0	Özel olarak imal edilir Custom Build	
60	72	M10	9.5	73		

PÇ

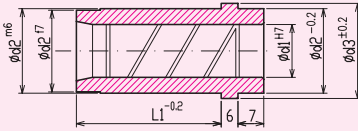
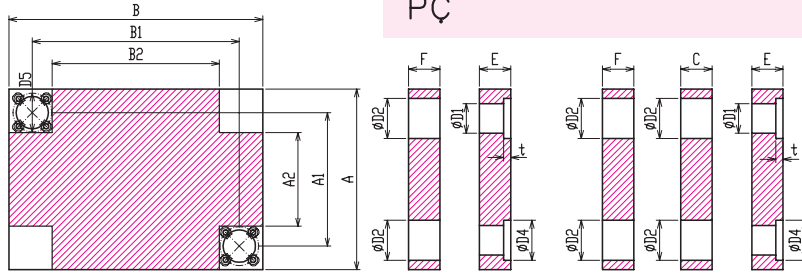

U S B			L1	
d1	d2	d3	Özel olarak imal edilir Custom Build	
60	72	79		

PA

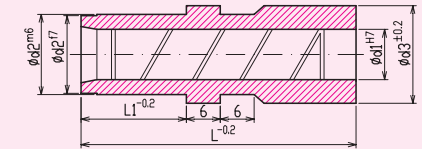
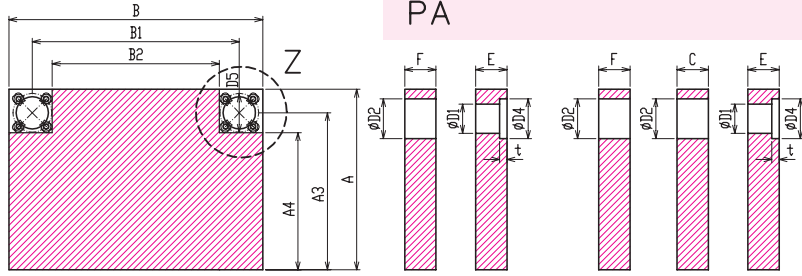

O S B				L1	
d1	d2	d3	L	Özel olarak imal edilir Custom Build	
60	72	79	140		

PO

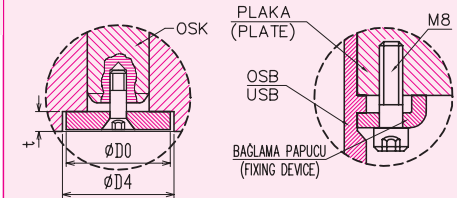
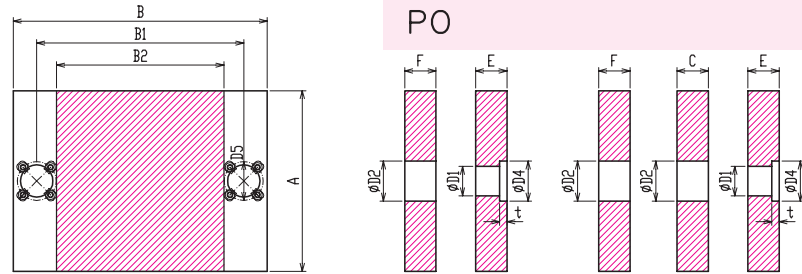

X Detayı/Detail Y Detayı/Detail

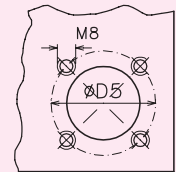
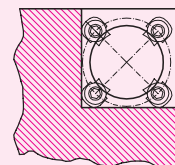

Z Detayı/Detail

KOD	E	F	C	A	B	A1	A2	A3	A4	B1	B2	t	D4	D1	D2	D5
5959				596	596	484	400	540	498	484	400	10.5	77	60	72	93
5964	57	57	47	596	646	484	400	540	498	534	450	10.5	77	60	72	93
5969	67	67		596	696	484	400	540	498	584	500	10.5	77	60	72	93
5974			57	596	746	484	400	540	498	634	550	10.5	77	60	72	93
5979	77	77		596	796	484	400	540	498	684	600	10.5	77	60	72	93

PKS



# Pres Kalıp Seti 646 Serisi 646 Series of Die Set

pkS  
646

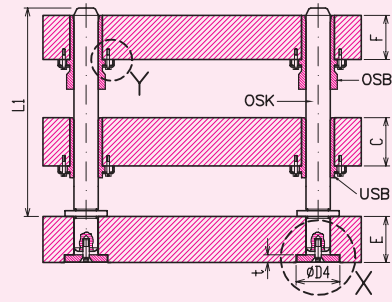
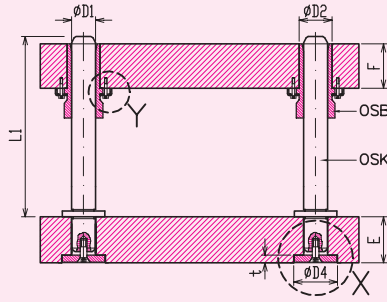

PD

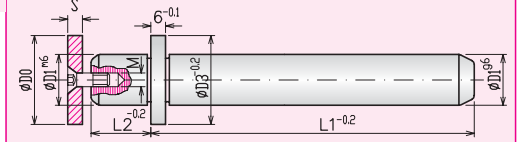
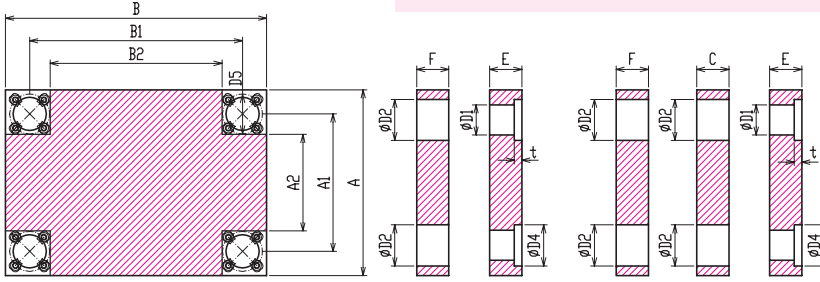

O S K					L1
D1	D3	M	S	D0	Özel olarak imal edilir Custom Build
60	72	M10	9,5	73	

PÇ

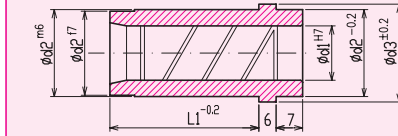
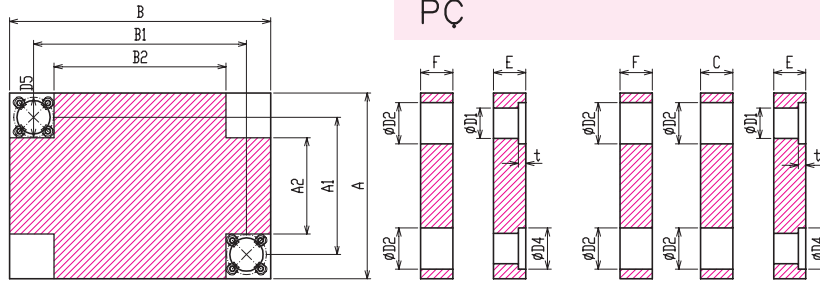

U S B I			L1
d1	d2	d3	Özel olarak imal edilir Custom Build
60	72	79	

PA

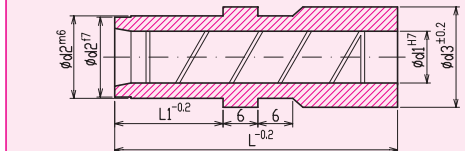
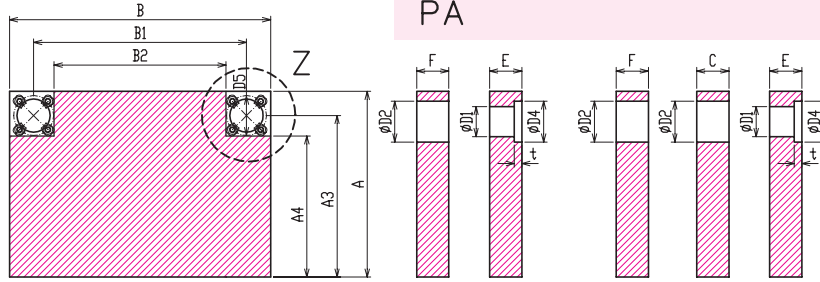

O S B I				L1
d1	d2	d3	L	Özel olarak imal edilir Custom Build
60	72	79	140	

PO

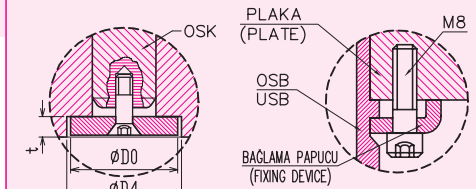
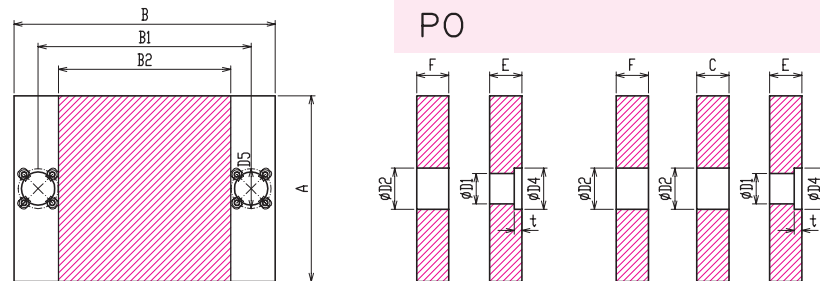

X Detayı/Detail Y Detayı/Detail

KOD	E	F	C	A	B	A1	A2	A3	A4	B1	B2	t	D4	D1	D2	D5
6464	57	57		646	646	534	450	590	548	534	450	10.5	77	60	72	93
6469			47	646	696	534	450	590	548	584	500	10.5	77	60	72	93
6474	67	67	57	646	746	534	450	590	548	634	550	10.5	77	60	72	93
6479	77	77		646	796	534	450	590	548	684	600	10.5	77	60	72	93

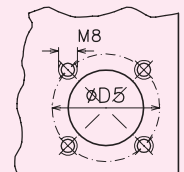
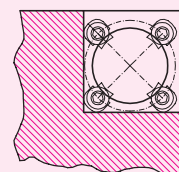

Z Detayı/Detail



# Pres Kalıp Seti 696 Serisi 696 Series of Die Set

pkS  
696

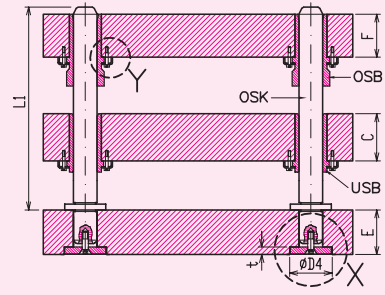
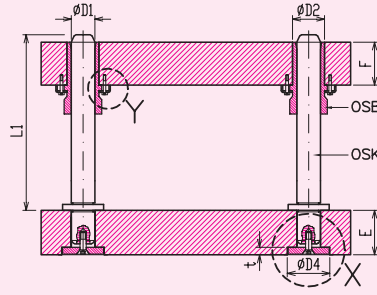

PD

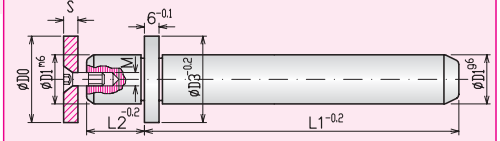
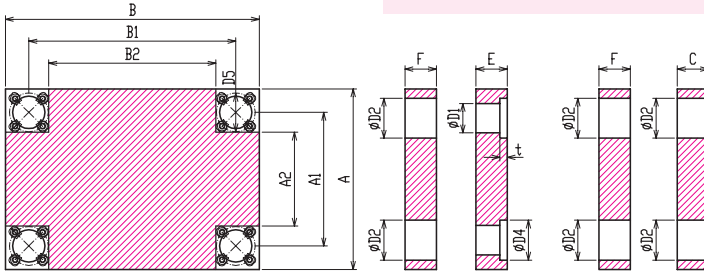

O S K					L1
D1	D3	M	S	D0	Özel olarak imal edilir Custom Build
60	72	M10	9.5	73	

PÇ

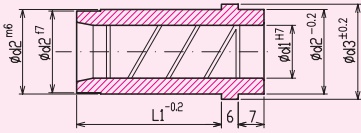
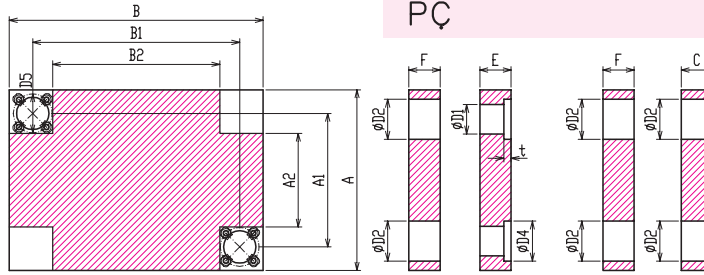

U S B			L1
d1	d2	d3	Özel olarak imal edilir Custom Build
60	72	79	

PA

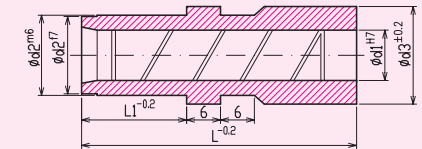
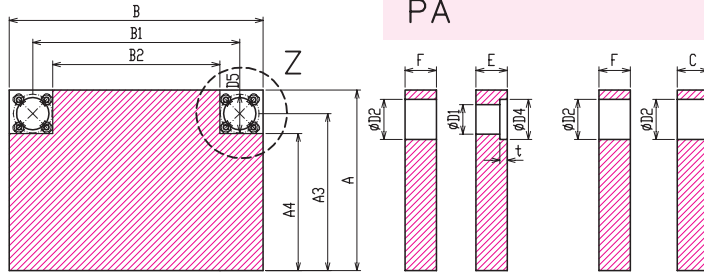

O S B				L1
d1	d2	d3	L	Özel olarak imal edilir Custom Build
60	72	79	140	

PO

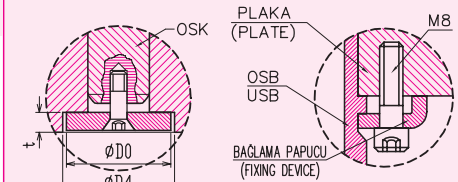
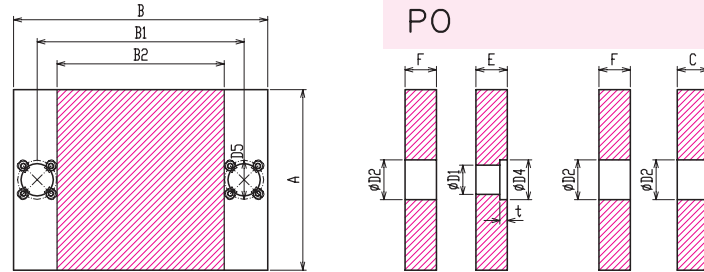

X Detayı/Detail Y Detayı/Detail

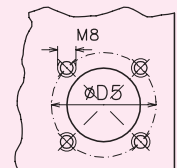
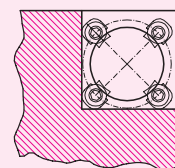

Z Detayı/Detail

KOD	E	F	C	A	B	A1	A2	A3	A4	B1	B2	t	D4	D1	D2	D5
6969	5	57	47	696	696	584	500	640	598	584	500	10.5	77	60	72	93
6974	67	67	57	696	746	584	500	640	598	634	550	10.5	77	60	72	93
6979	77	77	57	696	796	584	500	640	598	684	600	10.5	77	60	72	93

PKS

**OKSET**  
PRODUCTION TURKEY 2004

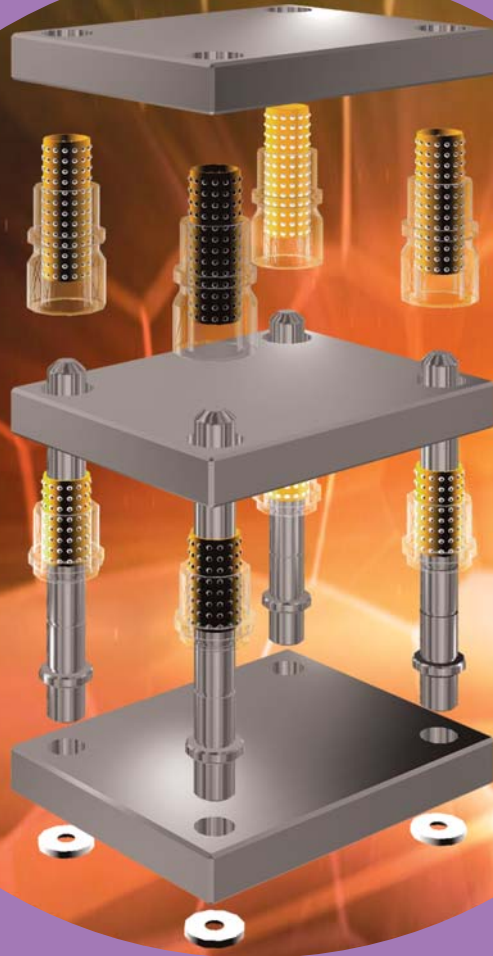

# Bilyalı Pres Kalıp Seti

## Ball Guide Die Set

**pk**sb****  
serisi / series

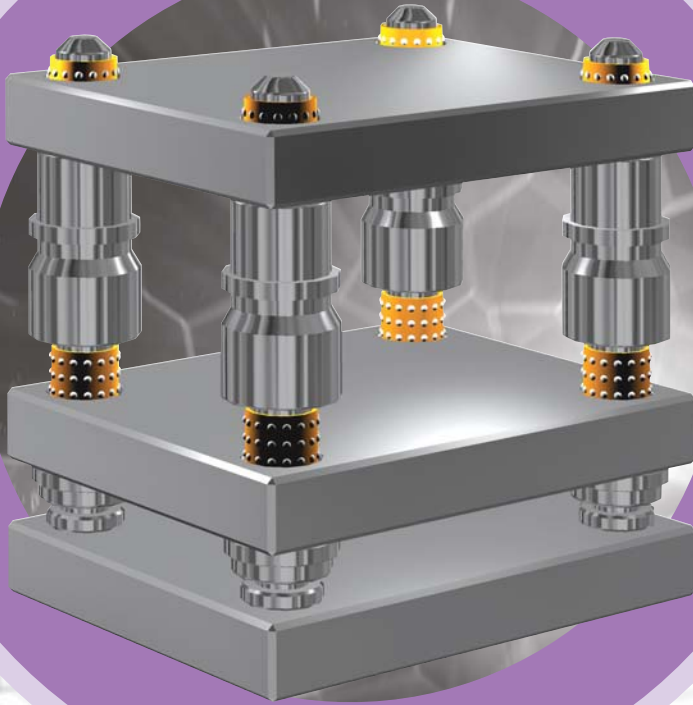

**OKSET**®



# Bilyalı Pres Kalıp Seti 156 Serisi

## 156 Series of Ball Guided Die Set

pk**sb**  
156

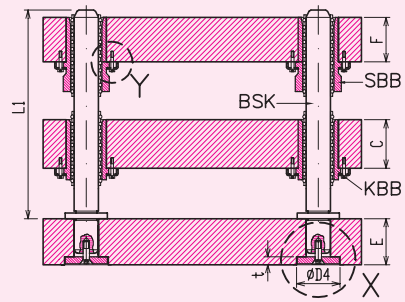
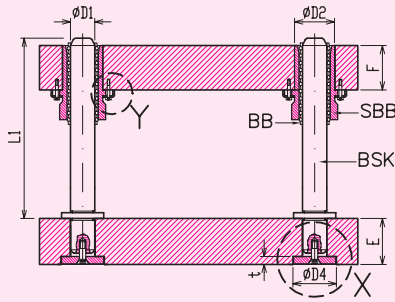

### PDB

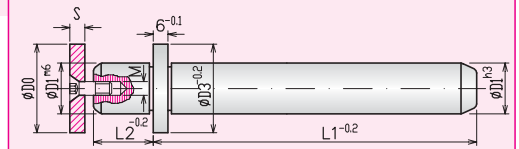
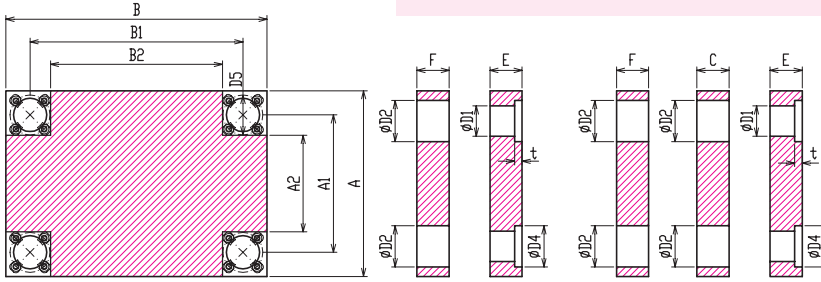

B S K					L1					
D1	D3	M	S	D0	L2	100	125	140	160	180
20	26	M6	5.5	25	20					
					25					
					35					

### PÇB

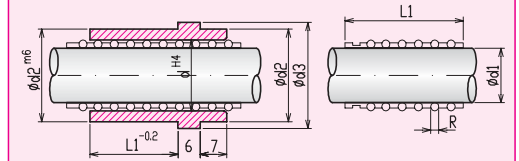
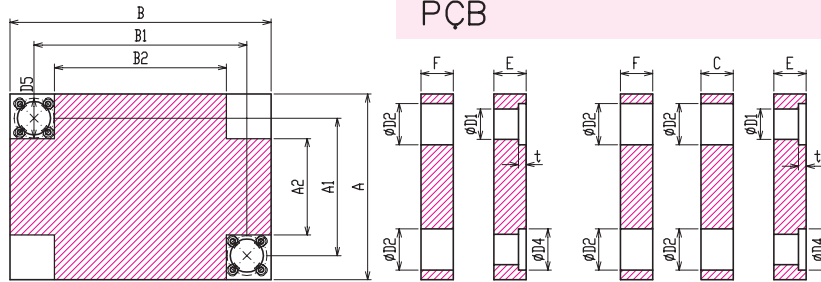

K B B					L1				B B					L1				
d	d1	d2	d3	L	26	36	46	56	d1	R	45	56	71	80	95			
26	20	34	39						20	3								

### PAB

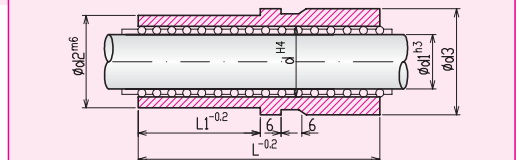
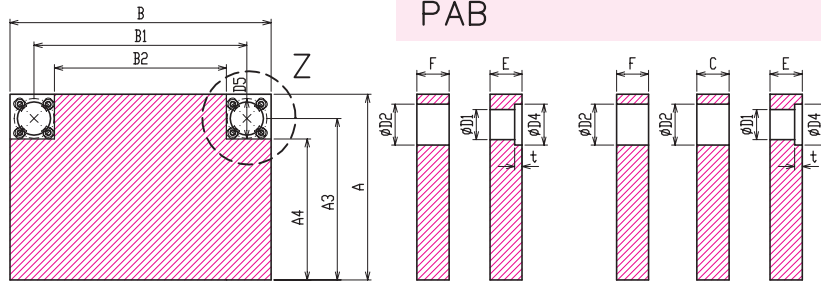

S B B					L1			
d	d1	d2	d3	L	26	36	46	56
26	20	34	39	80				

### POB

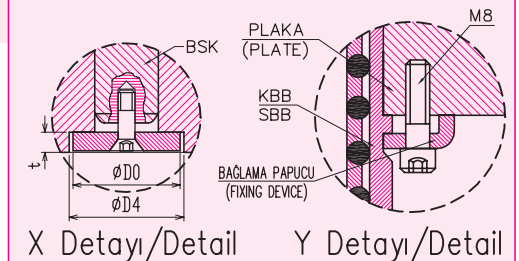
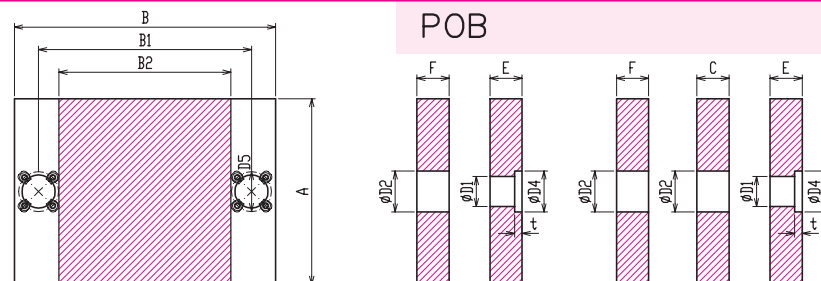

X Detayı/Detail

Y Detayı/Detail

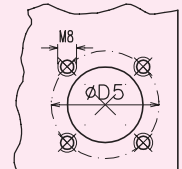
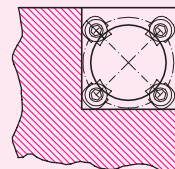

Z Detayı/Detail

KOD	E	F	C	A	B	A1	A2	A3	A4	B1	B2	t	D4	D1	D2	D5
1515	27	27		156	156	100	45	128	100	100	45	6.2	28.5	20	34	53
1519			27	156	196	100	45	128	100	140	85	6.2	28.5	20	34	53
1524	37	37		156	246	100	45	128	100	190	135	6.2	28.5	20	34	53
1529	47			156	296	100	45	128	100	240	185	6.2	28.5	20	34	53





# Bilyalı Pres Kalıp Seti 196 Serisi

## 196 Series of Ball Guided Die Set

pk**sb**  
196

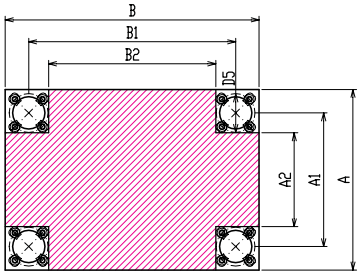
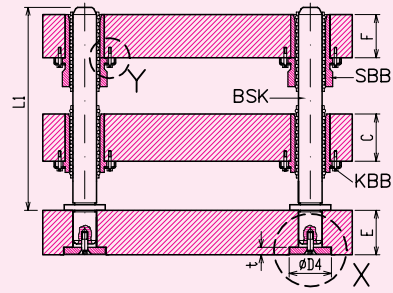
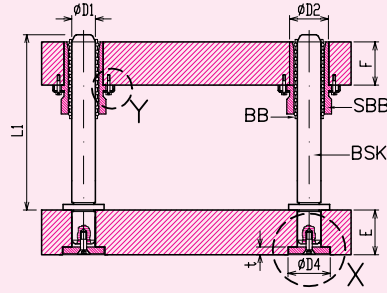

PDB

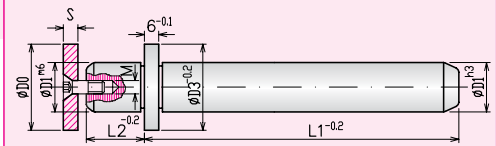
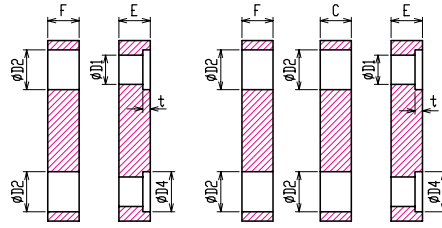

B S K					L1								
D1	D3	M	S	D0	L2	100	125	140	160	180	200	220	240
25	34	M8	5.5	32	20								
					25								
					35								

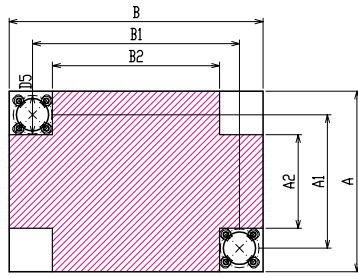

PÇB

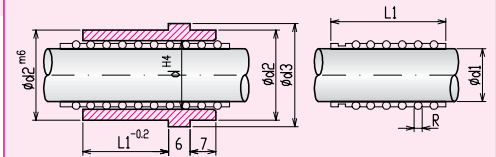
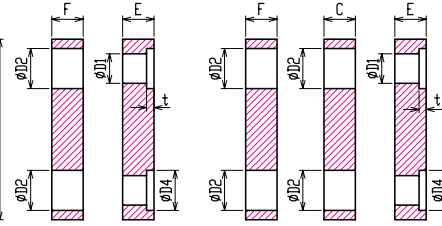

K B B					L1				B B I					L1			
d	d1	d2	d3	L	26	36	46	56	d1	R	45	56	71	80	105	140	
31	25	40	44						25	3							

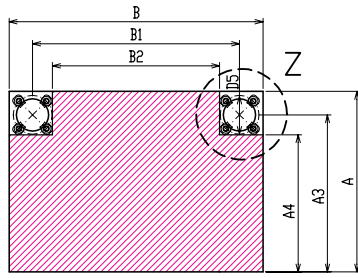

PAB

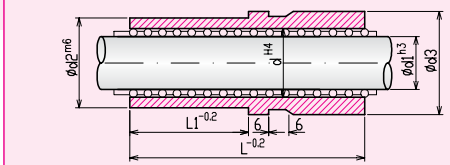
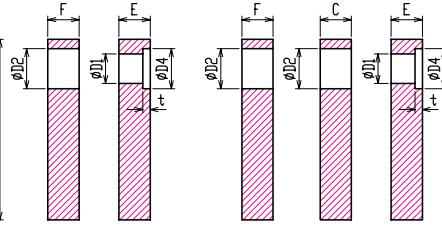

S B B					L1			
d	d1	d2	d3	L	26	36	46	56
31	25	40	44	90				

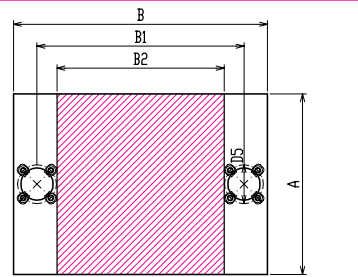

POB

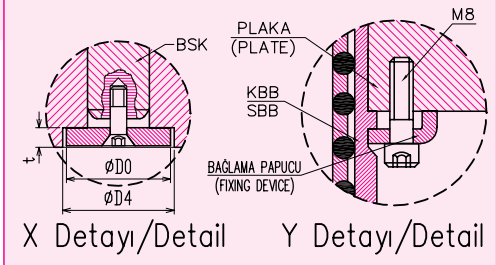
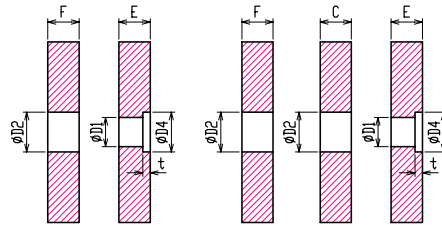

X Detayı/Detail

Y Detayı/Detail

KOD	E	F	C	A	B	A1	A2	A3	A4	B1	B2	t	D4	D1	D2	D5
1919				196	196	132	73	164	134	132	73	6.2	34.5	25	40	58
1924	27	27		196	246	132	73	164	134	182	123	6.2	34.5	25	40	58
1929	37		27	196	296	132	73	164	134	232	173	6.2	34.5	25	40	58
1934	47	37		196	346	132	73	164	134	282	223	6.2	34.5	25	40	58
1939				196	396	132	73	164	134	332	273	6.2	34.5	25	40	58

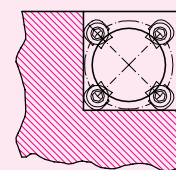

Z Detayı/Detail



# Bilyalı Pres Kalıp Seti 246 Serisi 246 Series of Ball Guided Die Set

pk**sb**  
246

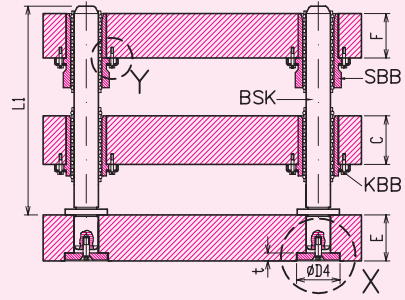
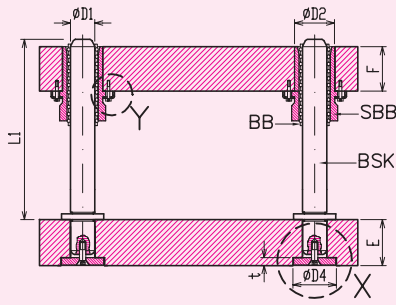

## PDB

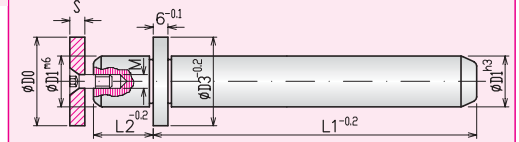
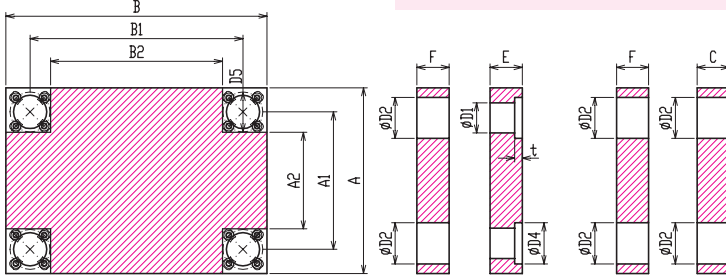

B S K				L1												
D1	D3	M	S	D0	L2	125	140	160	180	200	220	240	260	280	315	355
30	39	M8	7.5	40	2.8											
					3.5											
					4.5											

## PÇB

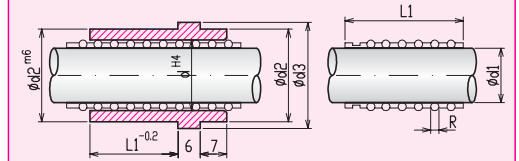
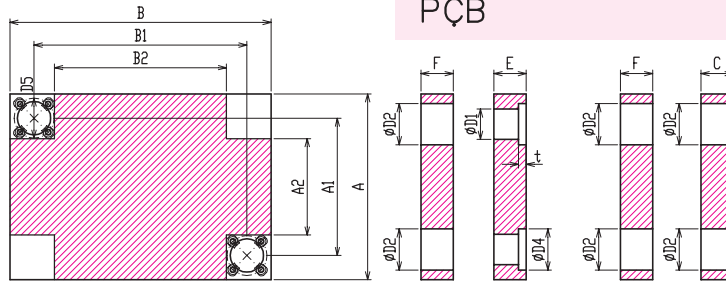

K B B				L1				B B							
d	d1	d2	d3	26	36	46	56	d1	R	56	80	95	105	120	140
38	30	48	54					30	4						

## PAB

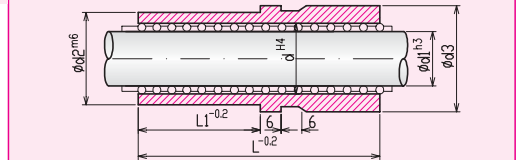
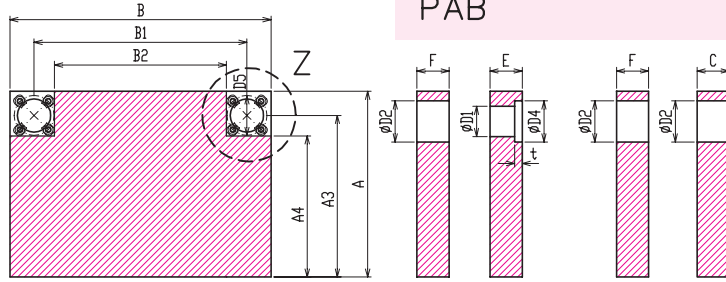

S B B				L1				
d	d1	d2	d3	L	26	36	46	56
38	30	48	54	100				

## POB

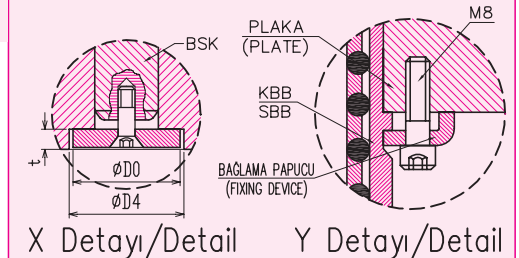
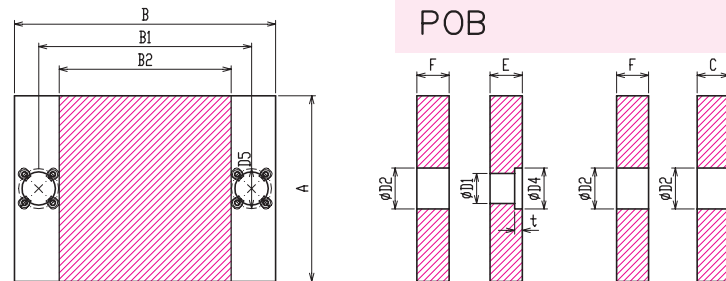

X Detayı/Detail

Y Detayı/Detail

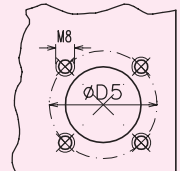
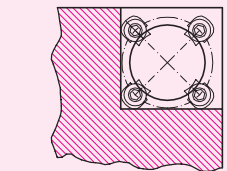

Z Detayı/Detail

KOD	E	F	C	A	B	A1	A2	A3	A4	B1	B2	t	D4	D1	D2	D5
2424				246	246	174	108	210	177	174	108	8.2	42	30	48	68
2429	37	37	27	246	296	174	108	210	177	224	158	8.2	42	30	48	68
2434	47			246	346	174	108	210	177	274	208	8.2	42	30	48	68
2439		47	37	246	396	174	108	210	177	324	258	8.2	42	30	48	68
2444	57			246	446	174	108	210	177	374	308	8.2	42	30	48	68



# Bilyalı Pres Kalıp Seti 296 Serisi 296 Series of Ball Guided Die Set

pk**sb**  
296

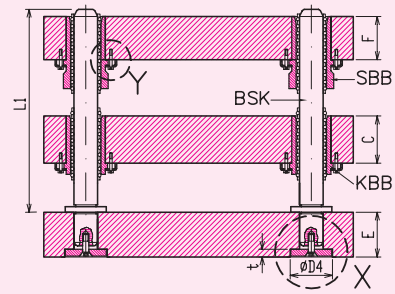
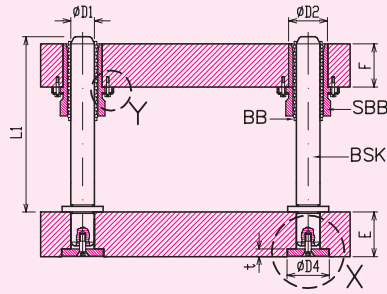

## PDB

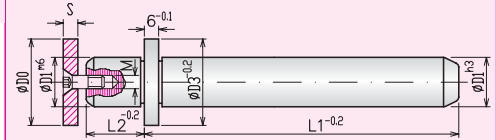
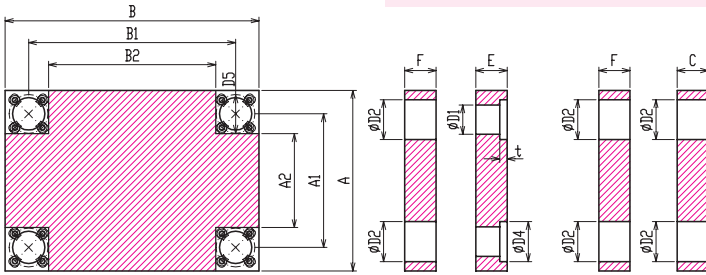

B S K				L1												
D1	D3	M	S	D0	L2	125	140	160	180	200	220	240	260	280	315	355
30	39	M8	7.5	40	28											
					35											
					45											
					25											
40	49	M8	9.5	50	35											
					45											

## PÇB

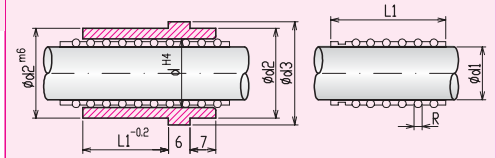
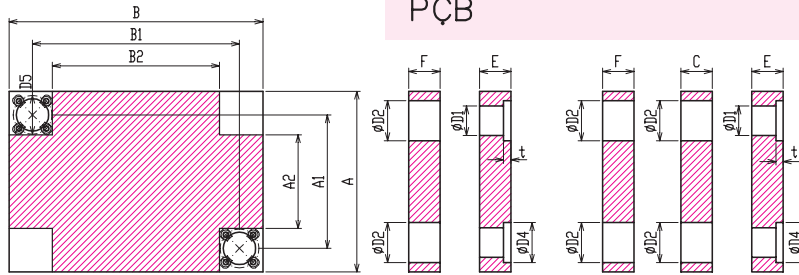

K B B				L1				B B				L1					
d	d1	d2	d3	26	36	46	56	d1	R	56	80	95	105	120	140	160	
38	30	48	54					30	4								
48	40	58	64					40	4								

## PAB

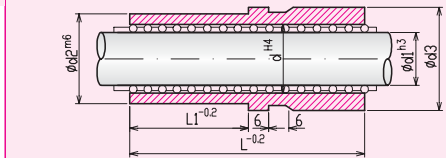
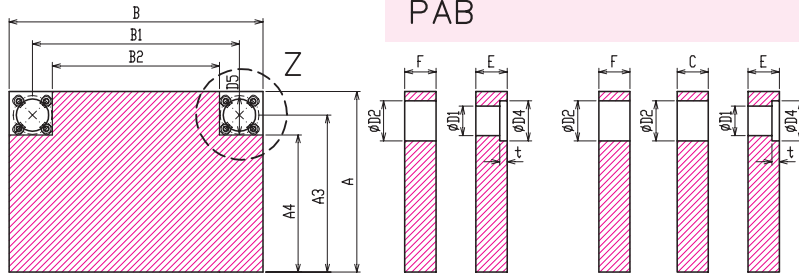

S B B				L1				
d	d1	d2	d3	L	26	36	46	56
38	30	48	54	100				
48	40	58	64	112				

## POB

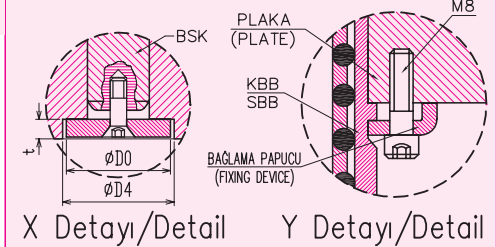
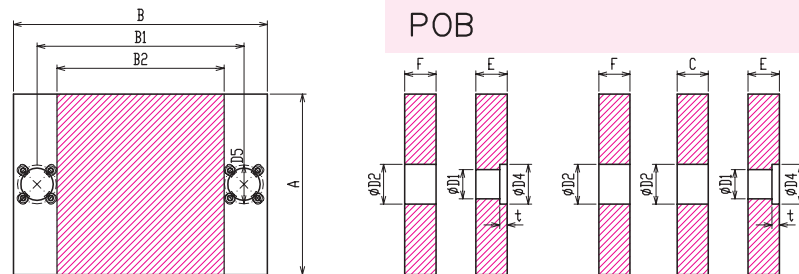

X Detayı/Detail Y Detayı/Detail

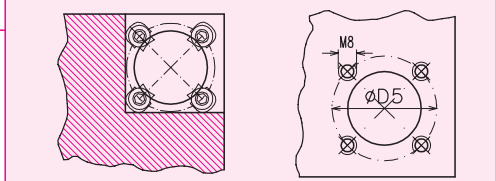

Z Detayı/Detail

KOD	E	F	C	A	B	A1	A2	A3	A4	B1	B2	t	D4	D1	D2	D5
2929				296	296	224	158	260	227	224	158	8.2	42	30	48	68
2934	37	37	37	296	346	224	158	260	227	274	208	8.2	42	30	48	68
2939	47	47	47	296	396	224	158	260	227	324	258	8.2	42	30	48	68
2944	57	57	47	296	446	224	158	260	227	374	308	8.2	42	30	48	68
2949				296	496	212	139	254	217	412	339	10.5	52	40	58	78



# Bilyalı Pres Kalıp Seti 346 Serisi

## 346 Series of Ball Guided Die Set

pk**sb**  
346

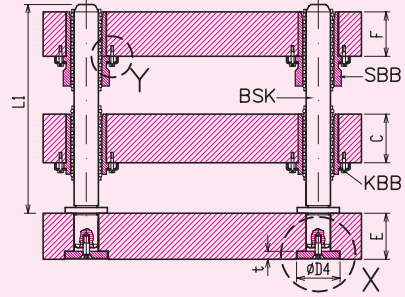
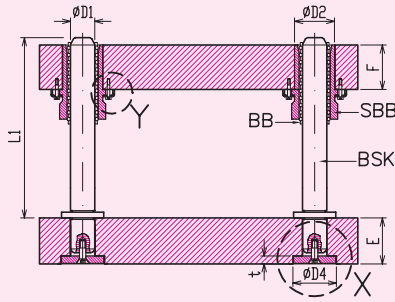

### PDB

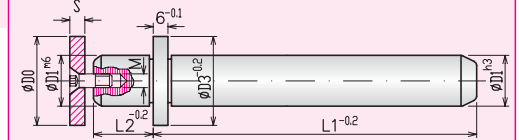
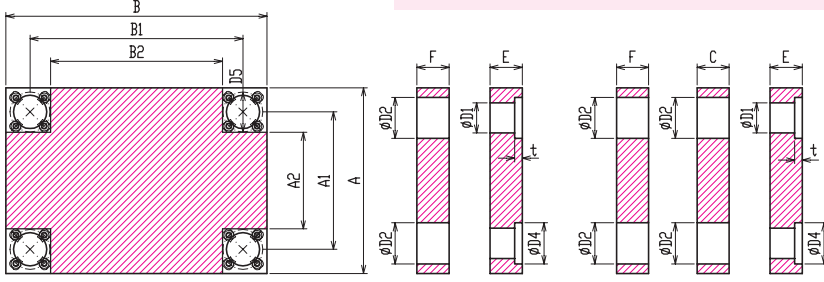

B S K					L1											
D1	D3	M	S	D0	L2	125	140	160	180	200	220	240	260	280	315	355
30	39	M8	7.5	40	28											
					35											
					45											
40	49	M8	9.5	50	25											
					35											
					45											

### PÇB

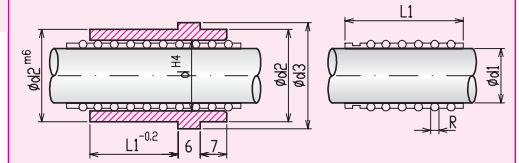
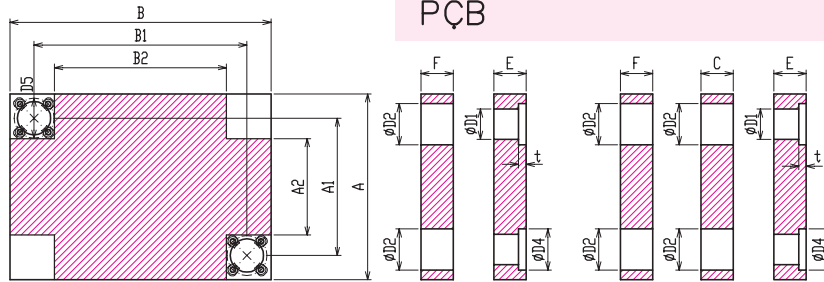

K B B					L1				B B				L1				
d	d1	d2	d3	L	26	36	46	56	d1	R	56	80	95	105	120	140	160
38	30	48	54	26					30	4							
48	40	58	64	112					40	4							

### PAB

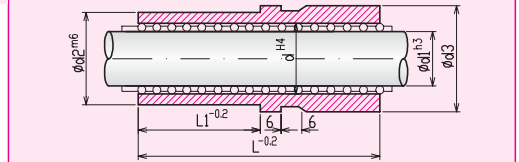
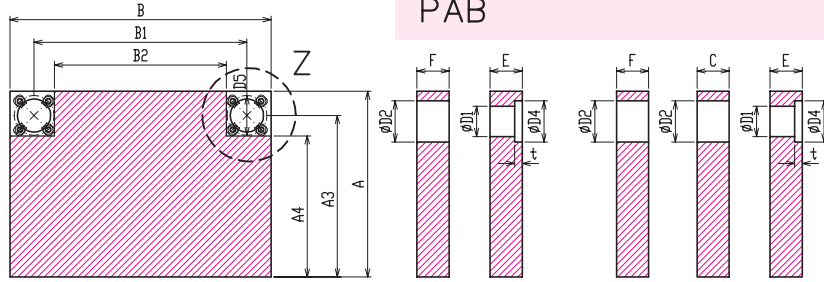

S B B					L1			
d	d1	d2	d3	L	26	36	46	56
38	30	48	54	100				
48	40	58	64	112				

### POB

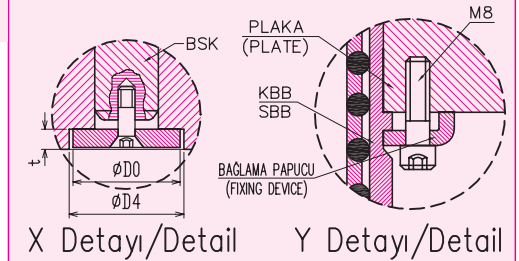
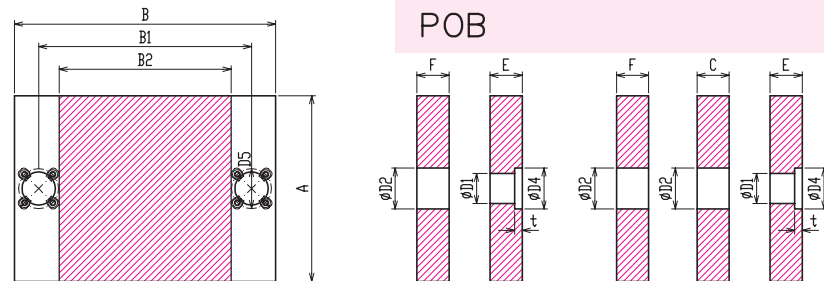

X Detayı/Detail

Y Detayı/Detail

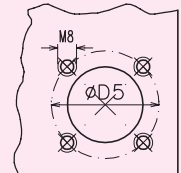
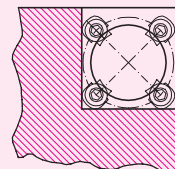

Z Detayı/Detail

KOD	E	F	C	A	B	A1	A2	A3	A4	B1	B2	t	D4	D1	D2	D5
3434	37	37		346	346	274	208	310	277	274	208	8.2	42	30	48	68
3439			37	346	396	274	208	310	277	324	258	8.2	42	30	48	68
3444	47	47		346	446	274	208	310	277	374	308	8.2	42	30	48	68
3449			47	346	496	262	189	304	267	412	339	10.5	52	40	58	78
3454	57	57		346	546	262	189	304	267	462	389	10.5	52	40	58	78



# Bilyalı Pres Kalıp Seti 396 Serisi 396 Series of Ball Guided Die Set

pk**sb**  
396

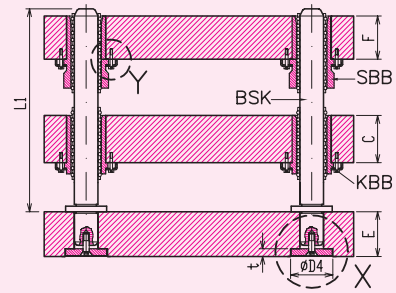
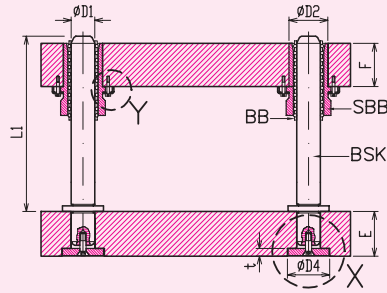

## PDB

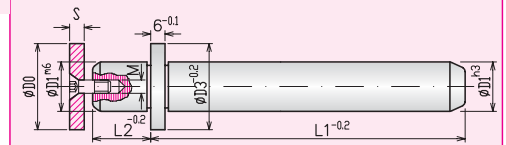
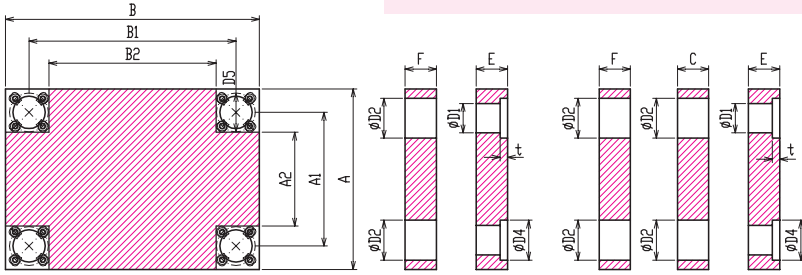

B S K					L1											
D1	D3	M	S	D0	L2	140	160	180	200	220	240	260	280	315	355	400
40	49	M8	9.5	50	45											
50	59	M10	9.5	60	45											
					55											

## PÇB

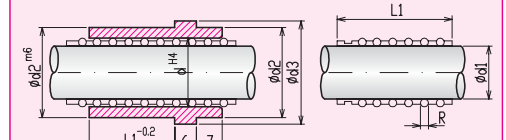
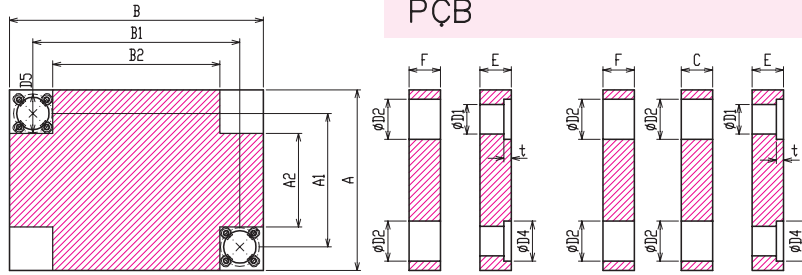

K B B					L1				B B					L1				
d	d1	d2	d3	L	26	36	46	56	d1	R	56	80	95	105	120	140	160	
48	40	58	64						40	4								
58	50	70	79						50	4								

## PAB

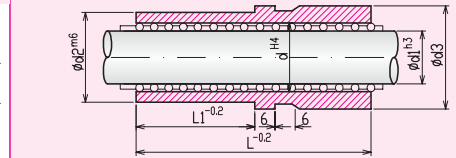
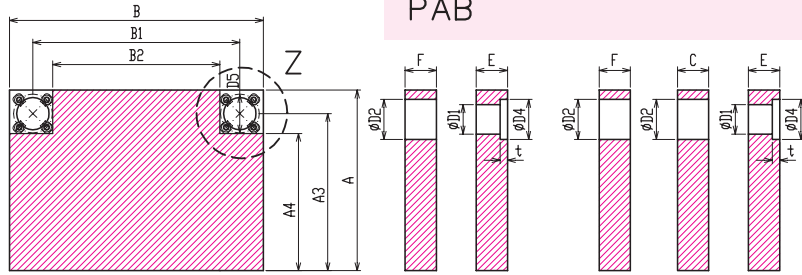

S B B					L1			
d	d1	d2	d3	L	26	36	46	56
48	40	58	64	112				
58	50	70	79	130				

## POB

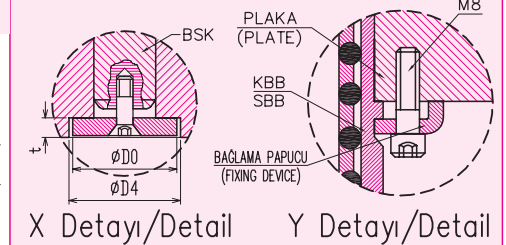
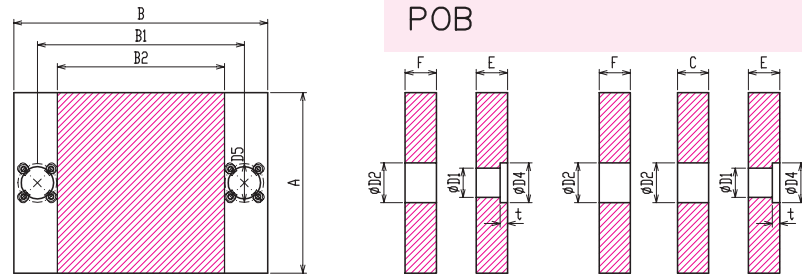

X Detayı/Detail Y Detayı/Detail

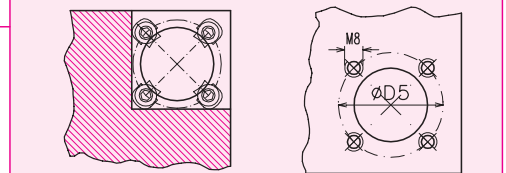

Z Detayı/Detail

KOD	E	F	C	A	B	A1	A2	A3	A4	B1	B2	t	D4	D1	D2	D5
3939				396	396	312	239	354	317	312	239	10.5	52	40	58	78
3944	47	47	37	396	446	312	239	354	317	362	289	10.5	52	40	58	78
3949				396	496	312	239	354	317	412	339	10.5	52	40	58	78
3954	57	57	47	396	546	312	239	354	317	462	389	10.5	52	40	58	78
3959	67		47	396	596	300	216	348	306	500	416	10.5	64	50	70	93



# Bilyalı Pres Kalıp Seti 446 Serisi

## 446 Series of Ball Guided Die Set

**pksb**  
**446**

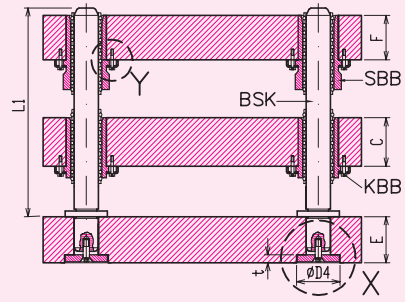
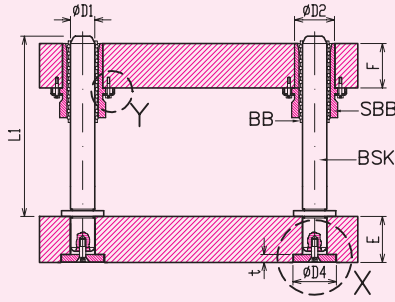

### PDB

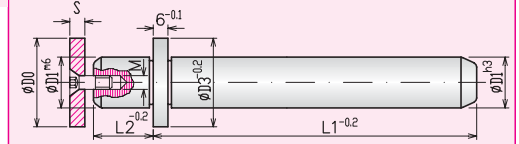
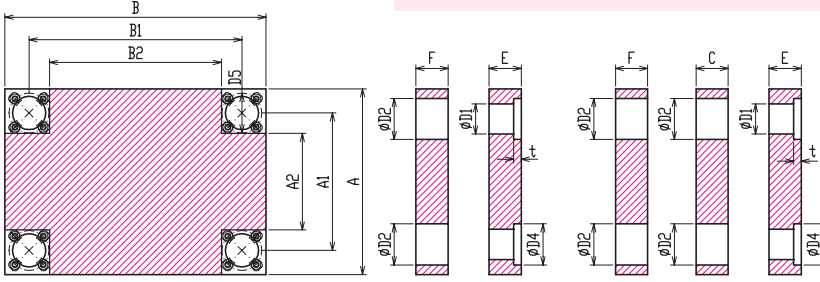

B S K					L1											
D1	D3	M	S	D0	L2	140	160	180	200	220	240	260	280	315	355	400
40	49	M8	9.5	50	35											
					45											
50	59	M10	9.5	60	45											
					55											

### PÇB

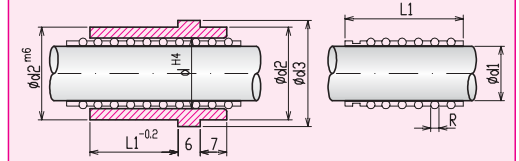
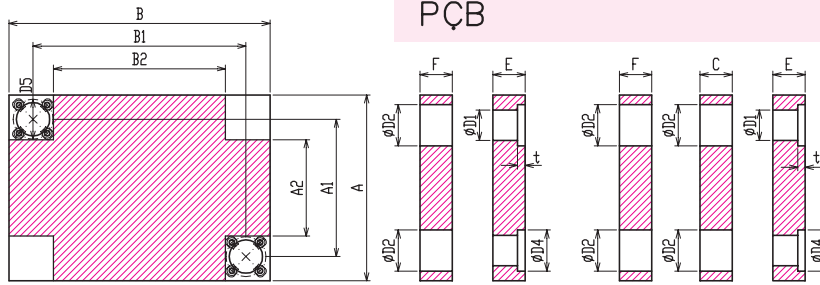

K B B					L1				B B		L1						
d	d1	d2	d3	L	26	36	46	56	d1	R	56	80	95	105	120	140	160
48	40	58	64						40	4							
58	50	70	79						50	4							

### PAB

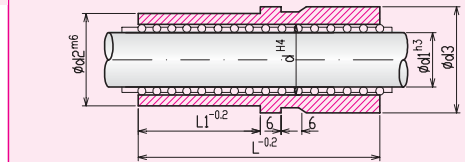
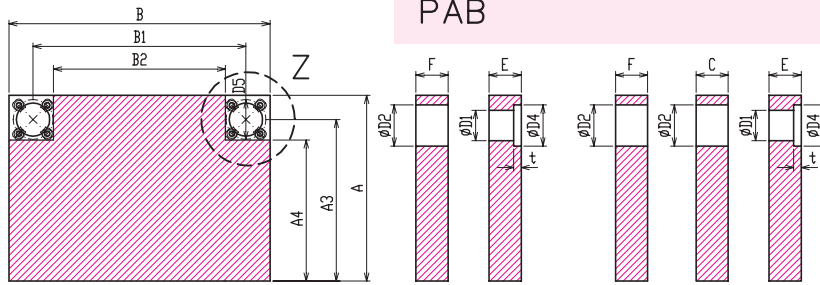

S B B					L1			
d	d1	d2	d3	L	26	36	46	56
48	40	58	64	112				
58	50	70	79	130				

### POB

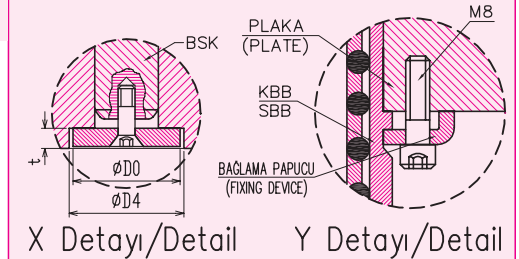
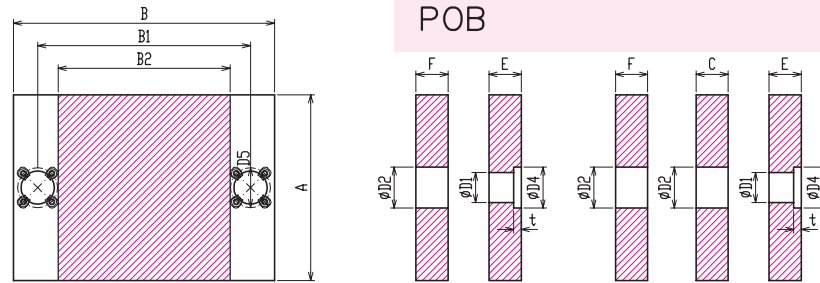

X Detayı/Detail

Y Detayı/Detail

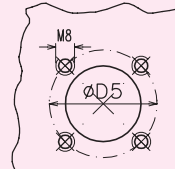
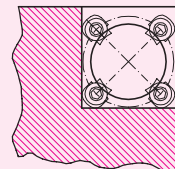

Z Detayı/Detail

KOD	E	F	C	A	B	A1	A2	A3	A4	B1	B2	t	D4	D1	D2	D5
4444	47	47	37	446	446	362	289	404	367	362	289	10.5	52	40	58	78
4449	57	57	47	446	496	362	289	404	367	412	339	10.5	52	40	58	78
4454	67	67	47	446	546	362	289	404	367	462	389	10.5	52	40	58	78
4459	67	67	47	446	596	350	266	398	356	500	416	10.5	64	50	70	93
4464	67	67	47	446	646	350	266	398	356	550	466	10.5	64	50	70	93



# Bilyalı Pres Kalıp Seti 496 Serisi

## 496 Series of Ball Guided Die Set

**pk**sb****  
**496**

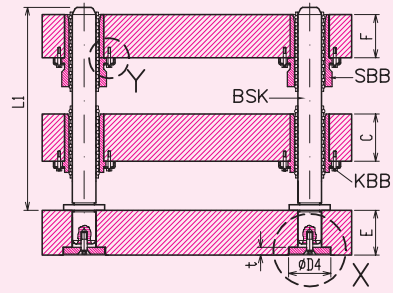
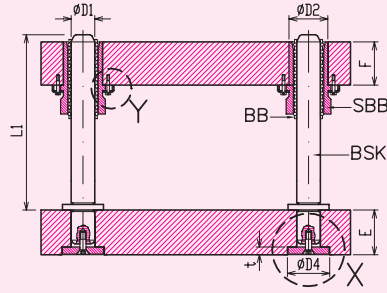

### PDB

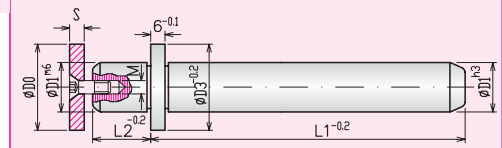
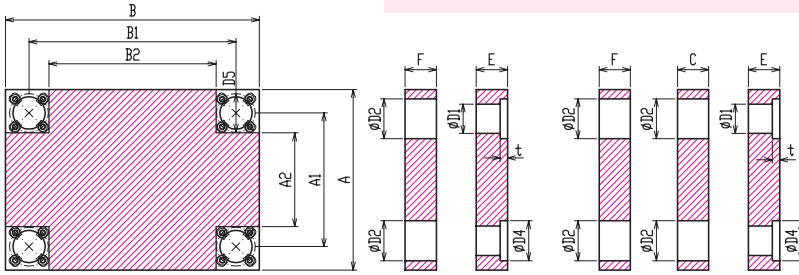

B S K					L1											
D1	D3	M	S	D0	L2	140	160	180	200	220	240	260	280	315	355	400
50	59	M10	9.5	60	35											
					45											
					55											

### PÇB

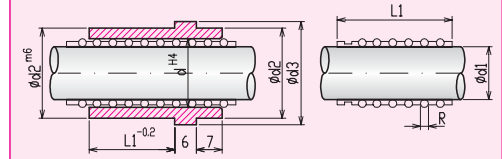
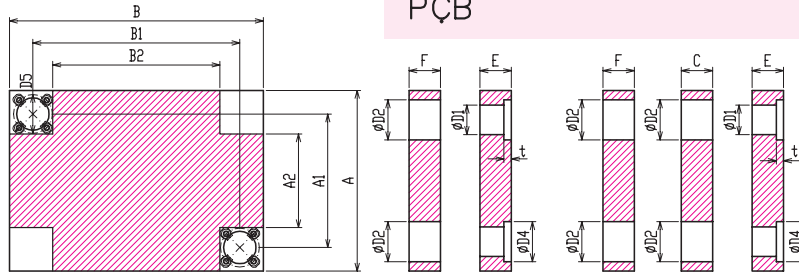

K B B					L1				B B			L1					
d	d1	d2	d3	L	26	36	46	56	d1	R	56	80	95	105	120	140	160
58	50	70	79						50	4							

### PAB

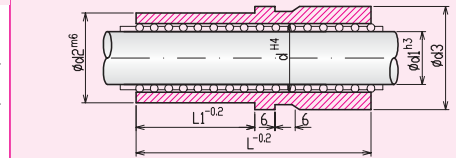
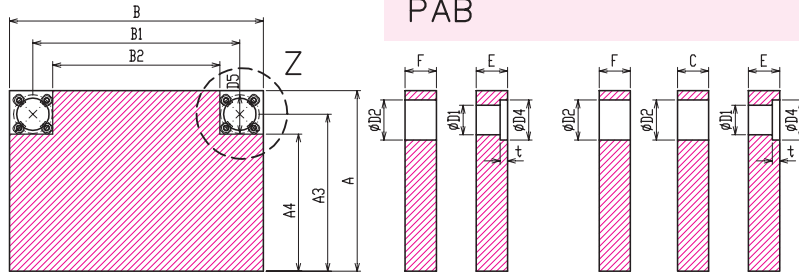

S B B					L1			
d	d1	d2	d3	L	26	36	46	56
58	50	70	79	130				

### POB

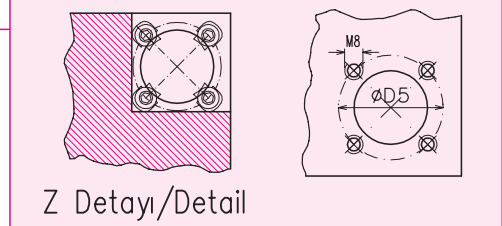
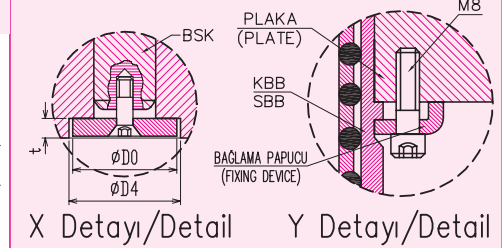
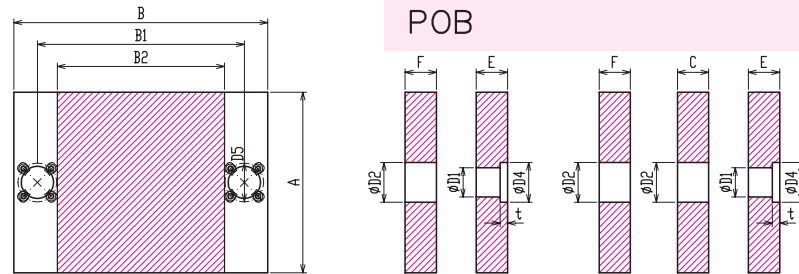

KOD	E	F	C	A	B	A1	A2	A3	A4	B1	B2	t	D4	D1	D2	D5
4949	47	47		496	496	400	316	448	406	400	316	10.5	64	50	70	93
4954				496	546	400	316	448	406	450	366	10.5	64	50	70	93
4959	57	57	47	496	596	400	316	448	406	500	416	10.5	64	50	70	93
4964				496	646	400	316	448	406	550	466	10.5	64	50	70	93
4969	67	67		496	696	400	316	448	406	600	516	10.5	64	50	70	93



# Bilyalı Pres Kalıp Seti 546 Serisi

## 546 Series of Ball Guided Die Set

**pk**sb****  
**546**

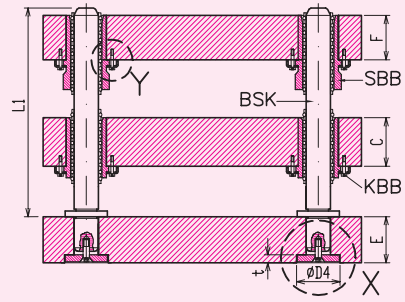
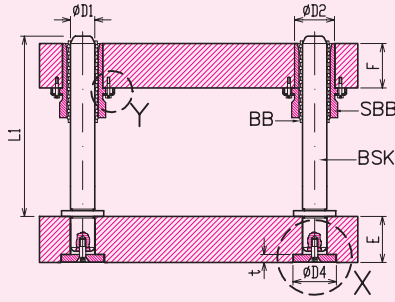

### PDB

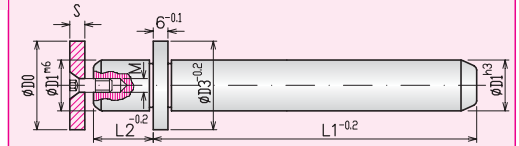
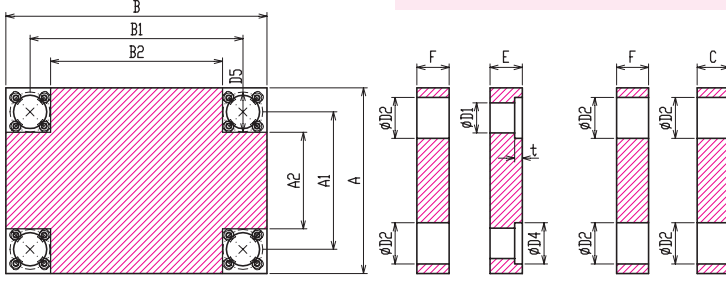

B S K						L1										
D1	D3	M	S	D0	L2	140	160	180	200	220	240	260	280	315	355	400
50	59	M10	9.5	60	35											
					45											
					55											

### PÇB

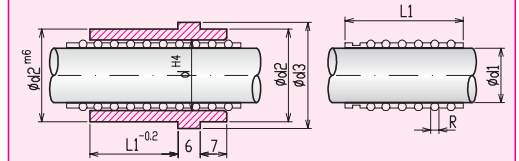
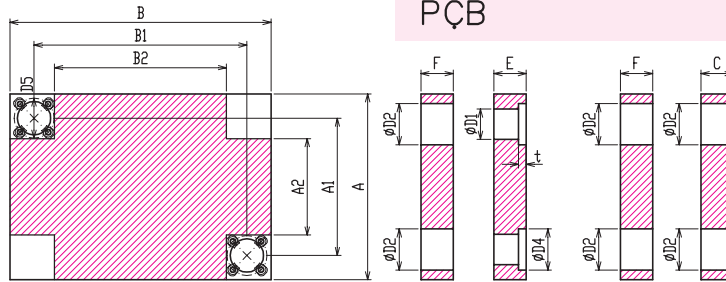

K B B				L1				B B		L1						
d	d1	d2	d3	26	36	46	56	d1	R	56	80	95	105	120	140	160
58	50	70	79					50	4							

### PAB

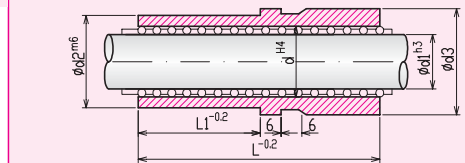
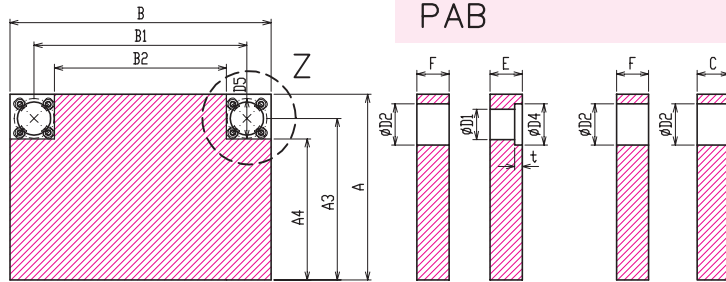

S B B				L1				
d	d1	d2	d3	L	26	36	46	56
58	50	70	79	130				

### POB

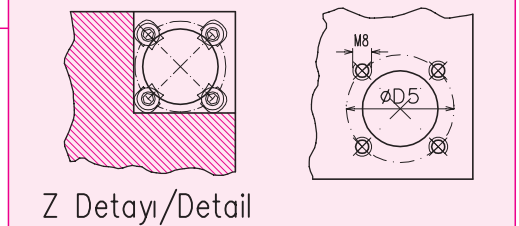
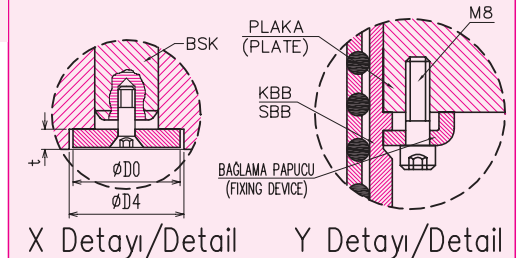
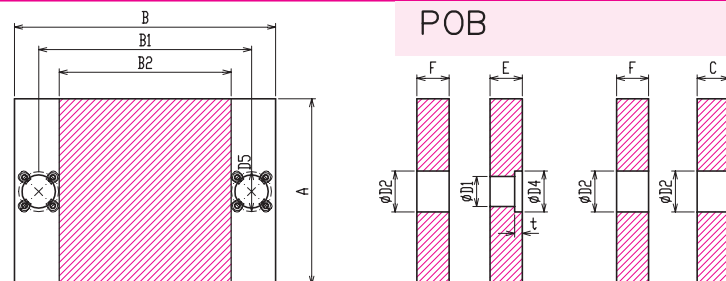

KOD	E	F	C	A	B	A1	A2	A3	A4	B1	B2	t	D4	D1	D2	D5
5454	47	47		546	546	450	366	498	456	450	366	10.5	64	50	70	93
5459				546	596	450	366	498	456	500	416	10.5	64	50	70	93
5464	57	57	47	546	646	450	366	498	456	550	466	10.5	64	50	70	93
5469				546	696	450	366	498	456	600	516	10.5	64	50	70	93
5474	67	67		546	746	450	366	498	456	650	566	10.5	64	50	70	93





# Bilyalı Pres Kalıp Seti 596 Serisi

## 596 Series of Ball Guided Die Set

**pkSB**  
**596**

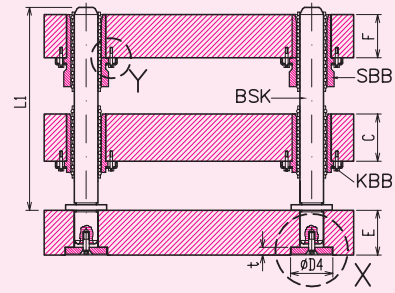
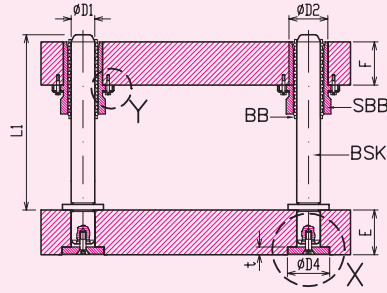

### PDB

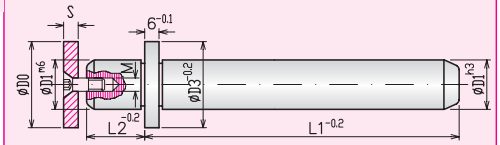
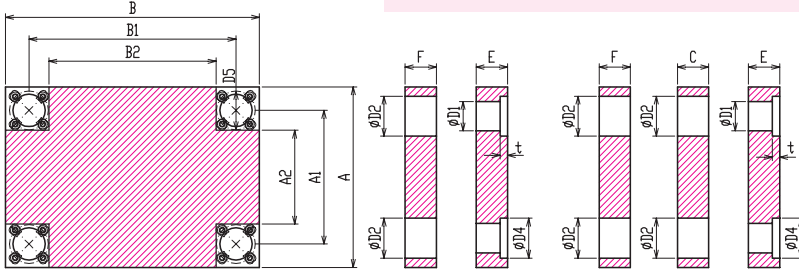

BSK					L1
D1	D3	M	S	D0	Özel imalat Custom build
60	72	M10	9.5	73	

### PQB

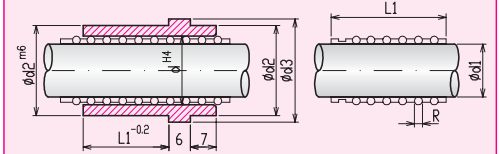
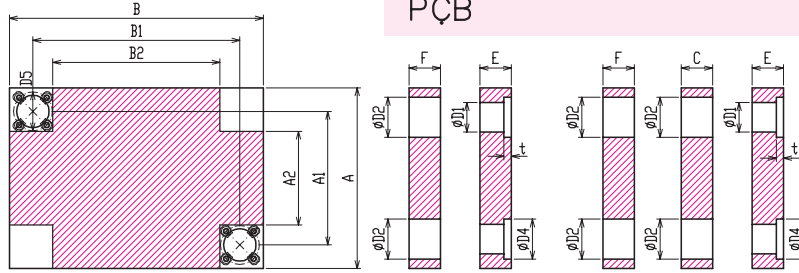

KBB					L1
d	d1	d2	d3	Özel imalat Custom build	
70	60	85	95		

BB		L1
d1	R	Özel imalat Custom build
60	5	

### PAB

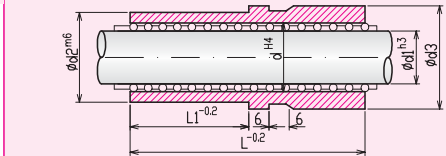
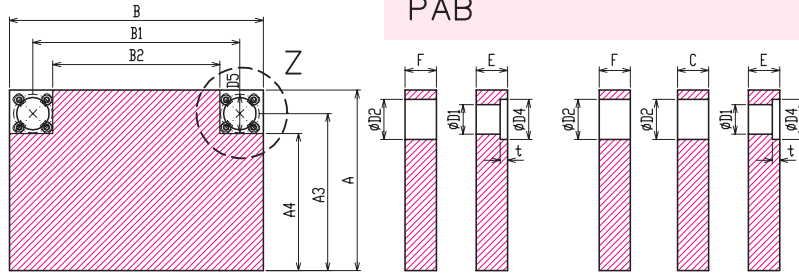

SBB					L1
d	d1	d2	d3	Özel imalat Custom build	
70	60	85	95		

### POB

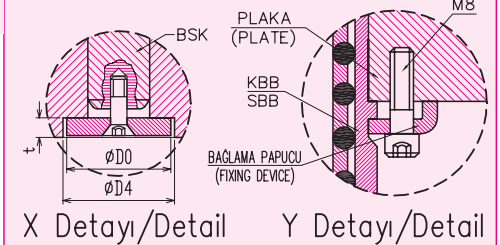
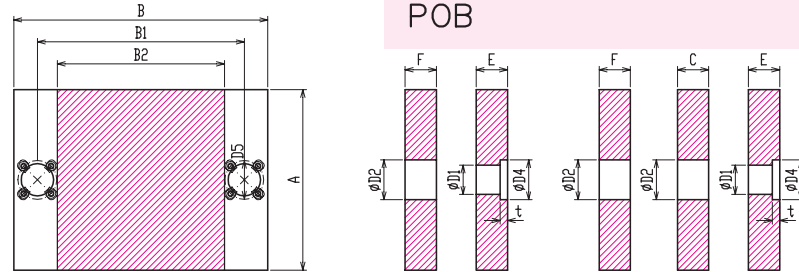

X Detayı/Detail

Y Detayı/Detail

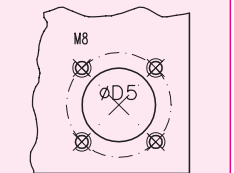
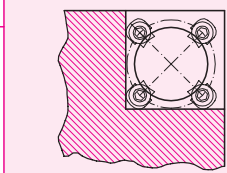

Z Detayı/Detail

KOD	E	F	C	A	B	A1	A2	A3	A4	B1	B2	t	D4	D1	D2	D5
5959	57	57		596	596	484	389	540	492	484	389	10.5	77	60	85	109
5964			47	596	646	484	389	540	492	534	439	10.5	77	60	85	109
5969	67	67		596	696	484	389	540	492	584	489	10.5	77	60	85	109
5974			57	596	746	484	389	540	492	634	539	10.5	77	60	85	109
5979	77	77		596	796	484	389	540	492	684	389	10.5	77	60	85	109



# Bilyalı Pres Kalıp Seti 646 Serisi

## 646 Series of Ball Guided Die Set

pk**sb**  
646

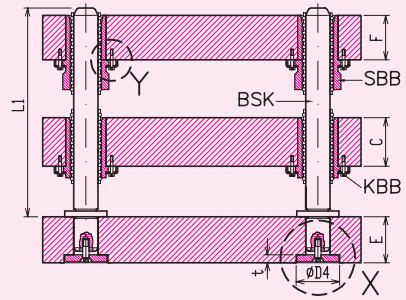
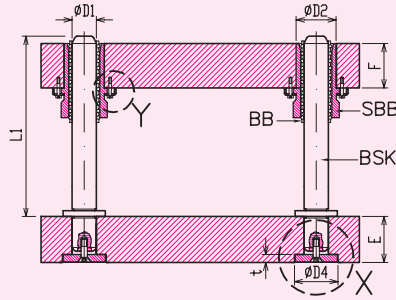

### PDB

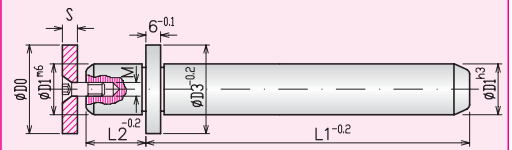
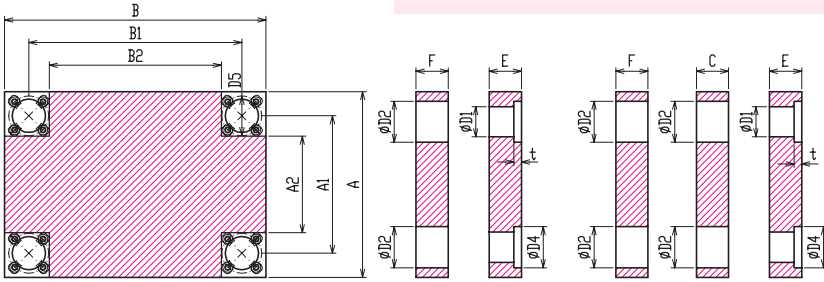

B S K					L1
D1	D3	M	S	D0	Özel imalat Custom build
60	72	M10	9,5	73	

### PÇB

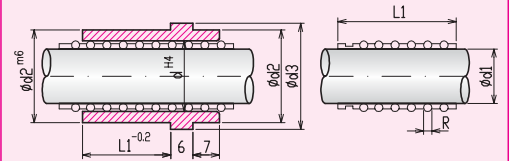
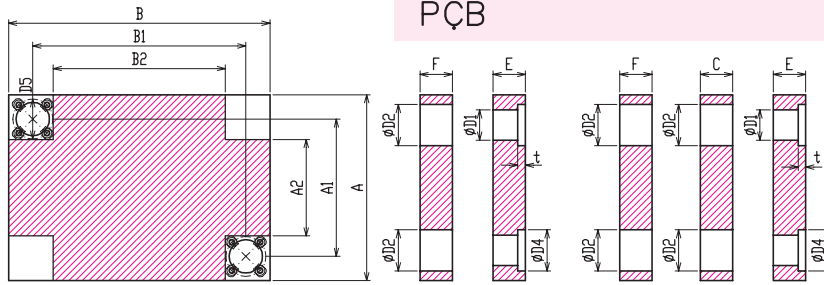

K B B					L1
d	d1	d2	d3		Özel imalat Custom build
70	60	85	95		

B B		L1
d1	R	Özel imalat Custom build
60	5	

### PAB

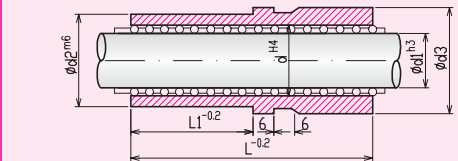
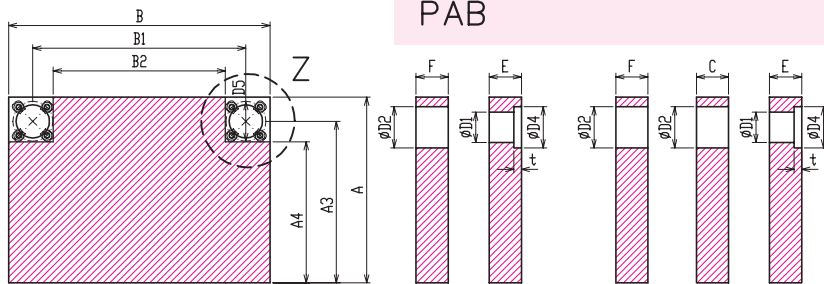

S B B					L1
d	d1	d2	d3		Özel imalat Custom build
70	60	85	95		

### POB

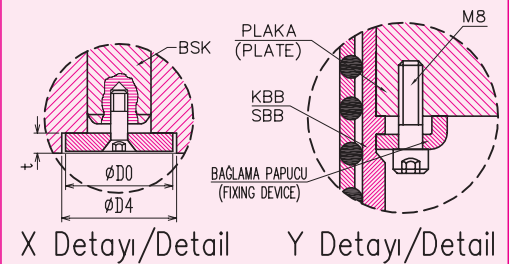
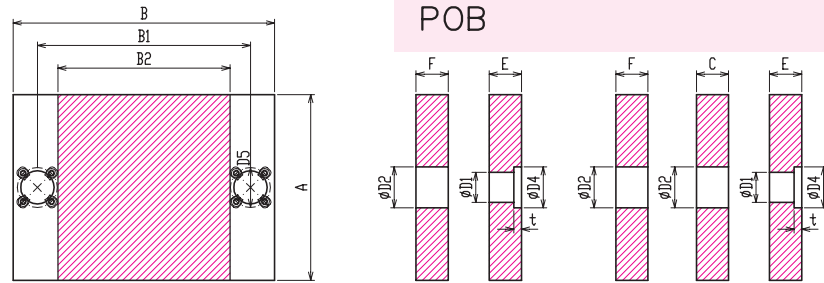

X Detay/Detail

Y Detay/Detail

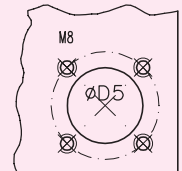
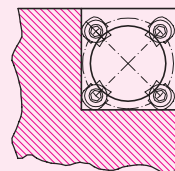

Z Detay/Detail

KOD	E	F	C	A	B	A1	A2	A3	A4	B1	B2	t	D4	D1	D2	D5
6464	57	57		646	646	534	439	590	542	534	439	10.5	77	60	85	109
6469			47	646	696	534	439	590	542	584	489	10.5	77	60	85	109
6474	67	67	57	646	746	534	439	590	542	634	539	10.5	77	60	85	109
6479	77	77		646	796	534	439	590	542	684	589	10.5	77	60	85	109



# Bilyalı Pres Kalıp Seti 696 Serisi

## 696 Series of Ball Guided Die Set

pkSB  
696

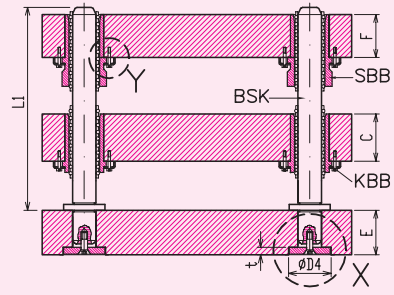
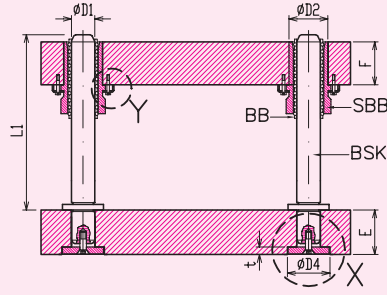

### PDB

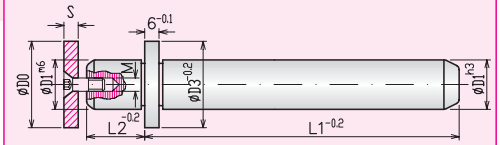
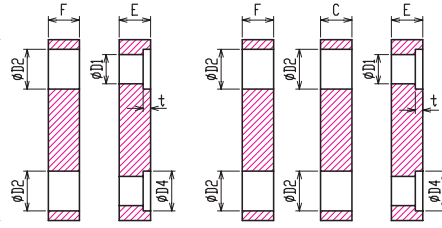
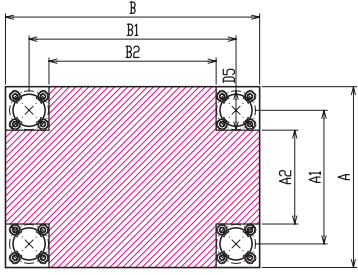

B	S	K	L1		
D1	D3	M	S	D0	Özel imalat
60	72	M10	9.5	73	Custom build

### PÇB

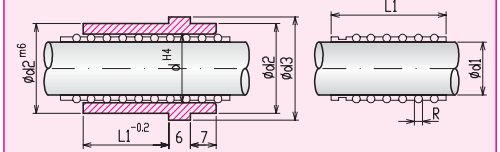
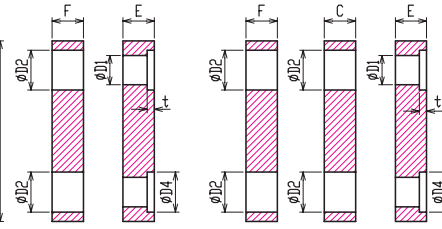
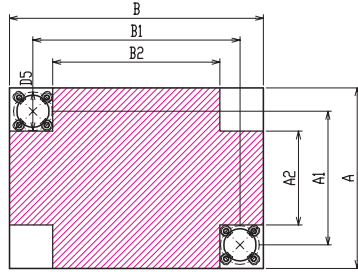

K	B	B	L1	
d	d1	d2	d3	Özel imalat
70	60	85	95	Custom build

B	B	L1
d1	R	Özel imalat
60	5	Custom build

### PAB

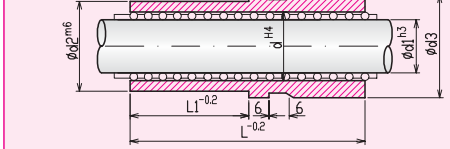
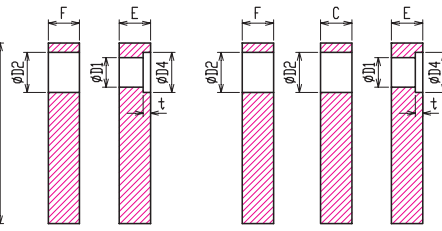
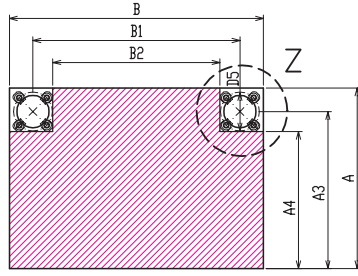

S	B	B	L1	
d	d1	d2	d3	Özel imalat
70	60	85	95	Custom build

### POB

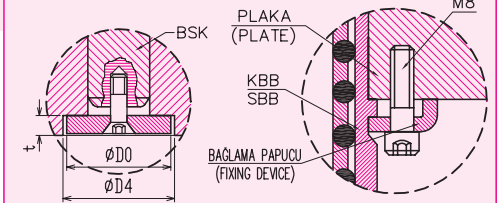
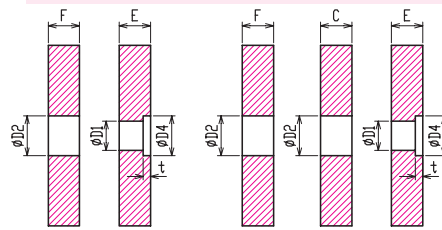
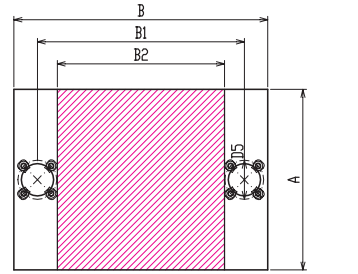

X Detayı/Detail

Y Detayı/Detail

KOD	E	F	C	A	B	A1	A2	A3	A4	B1	B2	t	D4	D1	D2	D5
6969	57	57	47	696	696	584	489	640	592	584	489	10.5	77	60	85	109
6974	67	67		696	746	584	489	640	592	634	539	10.5	77	60	85	109
6979	77	77	57	696	796	584	489	640	592	684	589	10.5	77	60	85	109

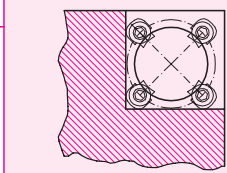

Z Detayı/Detail

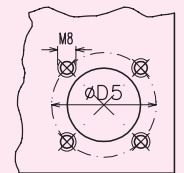



# Taşlanmış Plakalar Ready Plates

A	L	H										
		27	37	47	57	67	77	87	97	107	117	127
156	156											
	196											
	246											
	296											
196	346											
	196											
	246											
	296											
246	346											
	396											
	446											
	296											
296	346											
	396											
	446											
	496											
346	346											
	396											
	446											
	496											
396	546											
	396											
	446											
	496											
446	546											
	496											
	546											
	596											
496	646											
	496											
	546											
	596											
546	646											
	596											
	646											
	696											
596	746											
	596											
	646											
	696											
646	746											
	696											
	746											
	796											
696	696											
	746											
	796											

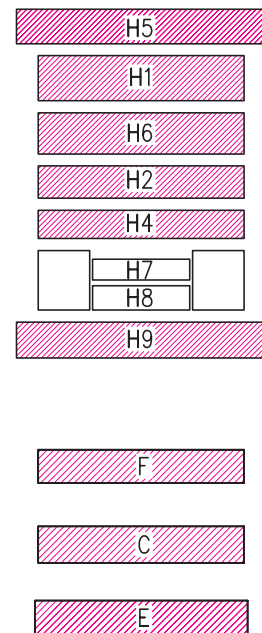
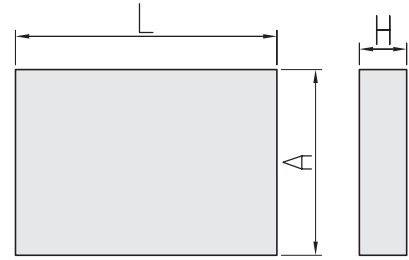
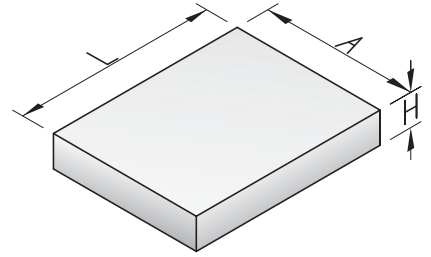

# kolon ve burçlar

OKSET  
PRODUCTION TURKEY 2004

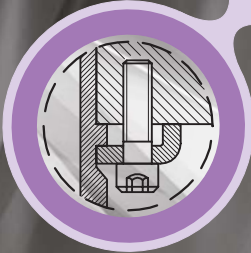
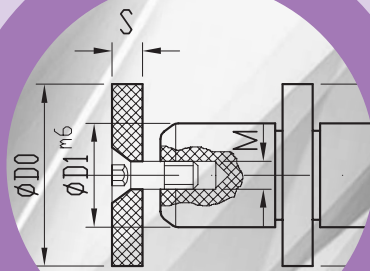
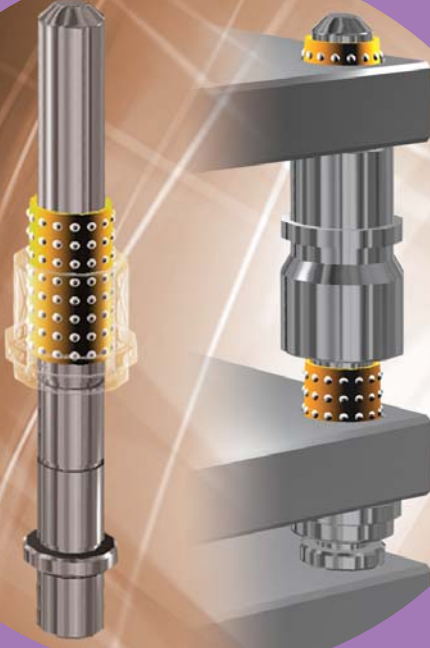



# Kolon ve Burçlar Pillar and Bushes

## ARKASI KALIN KOLON / GUIDE PILLAR

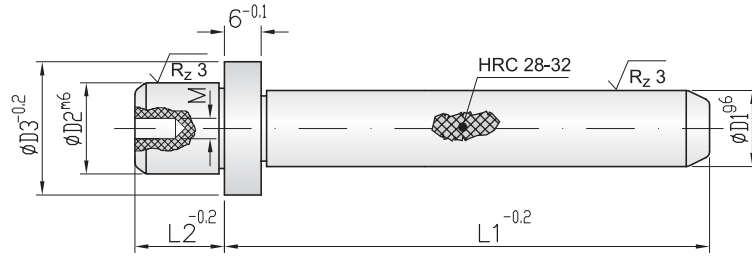

Metal / Steel AISI 7131					Sertlik Derecesi / Hardness 60-62 HRC												
A K K					L1												
D1	D2	D3	M	L2	100	125	140	160	180	200	220	240	260	280	315	355	400
20	28	34	M6	25													
				35													
25	34	39	M8	25													
				35													
30	39	44	M8	35													
				45													

## ORTADAN FLANŞLI BURÇ / MIDDLE FLANGED BUSHING

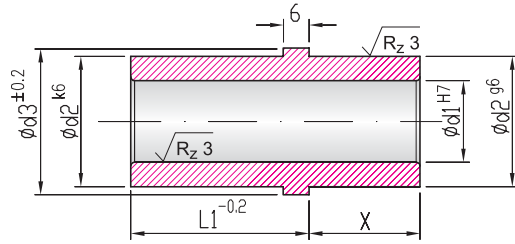

Metal / Steel AISI 7131					Sertlik Derecesi / Hardness 60-62 HRC	
O F B					L1	
d1	d2	d3	X	a	16	21
16	24	28	12	6		
20	28	32	12	6		
25	34	38	16	6		
30	39	43	16	6		

## SABİTLEME DİSKİ / RETAINING PLATES

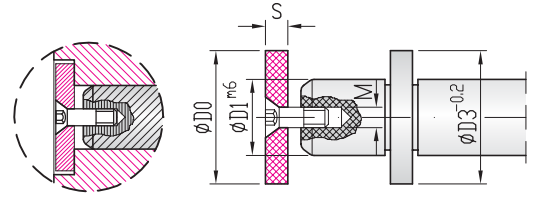

D1	D3	M	S	D0
20	28	M6	5.5	25
25	33	M8	5.5	32
30	38	M8	7.5	40
40	48	M8	9.5	50
50	58	M10	9.5	60
60	72	M10	9.5	73

## ŞAPKALI KOLON / GUIDE PILLAR

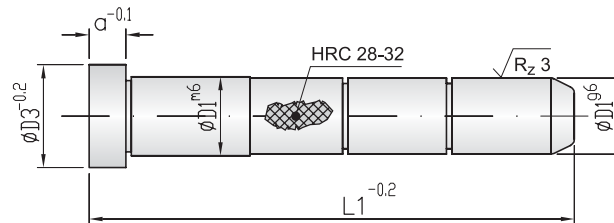

Metal / Steel AISI 7131			Sertlik Derecesi / Hardness 60-62 HRC									
S K			L2									
D1	D3	a	60	80	100	120	140	160	180	200	220	250
16	20	10										
20	24	10										
25	29	10										
30	34	12										



# Kolon ve Burçlar Pillar and Bushes

## ORTADAN ŞAPKALI KOLON / GUIDE PILLAR

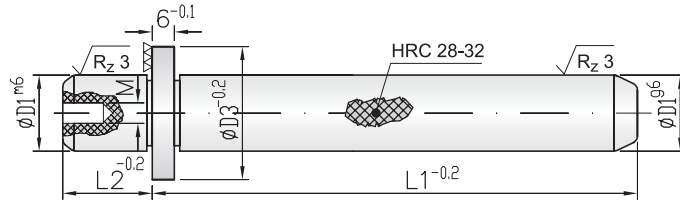

Metal / Steel AISI 7131				Sertlik Derecesi / Hardness 60-62 HRC												
O S K				L1												
D1	D3	M	L2	100	125	140	160	180	200	220	240	260	280	315	355	400
20	28	M6	20/25/35													
25	33	M8	20/25/35													
30	38	M8	28/35/45													
40	48	M8	25/35/45													
50	58	M10	35/45/55													
60	72	M10		ÖZEL İMALAT / CUSTOM BUILD												

## ÜSTTEN ŞAPKALI BURÇ / GUIDE BUSH

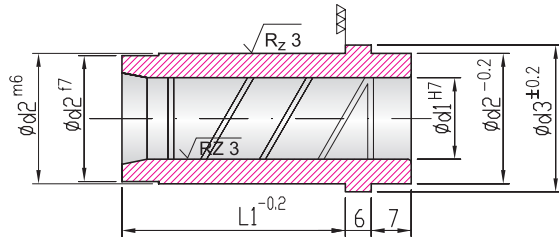

Metal / Steel AISI 7131			Sertlik Derecesi / Hardness 60-62 HRC		
U S B			L1		
d1	d2	d3	26	36	46
20	28	34			
25	34	39			
30	39	44			
40	50	54			
50	60	64			
60	72	79	ÖZEL İMALAT/CUSTOM BUILD		

## BAĞLAMA PAPUCU / FIXING DEVICES

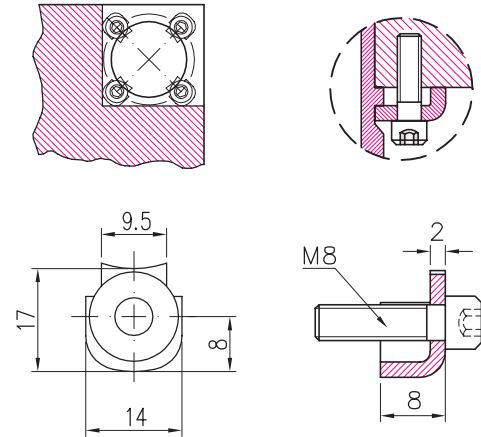

## ORTADAN ŞAPKALI BURÇ / GUIDE BUSH

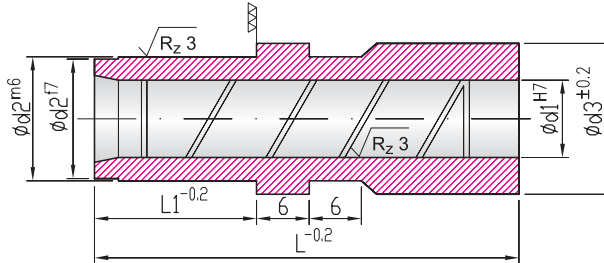

Metal / Steel AISI 7131				Sertlik Derecesi / Hardness 60-62 HRC			
O S B				L1			
d1	d2	d3	L	26	36	46	56
20	28	34	70				
25	34	39	80				
30	39	44	90				
40	50	54	100				
50	60	64	120				
60	72	79	140	ÖZEL İMALAT / CUSTOM BUILD			



# Kolon ve Burçlar Pillar and Bushes

## BİLYALI ŞAPKALI KOLON / BALL GUIDE PILLAR

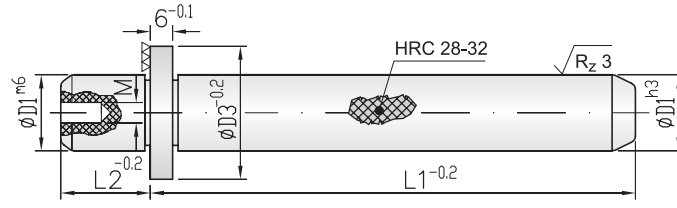

Metal / Steel AISI 8620				Sertlik Derecesi / Hardness 60-62 HRC															
B S K				L1															
D1	D3	M	L2	100	125	140	160	180	200	220	240	260	280	315	355	400			
20	26	M6	20/25/35																
25	34	M8	20/25/35																
30	39	M8	28/35/45																
40	49	M8	25/35/45																
50	59	M10	35/45/55																
60	72	M10																	

ÖZEL İMALAT / CUSTOM BUILD

## KISA BİLYALI BURÇ / BALL GUIDE BUSH

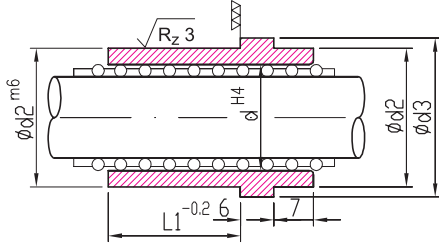

Metal / Steel AISI 8620				Sertlik Derecesi / Hardness 60-62 HRC			
K B B				L1			
d	d1	d2	d3	26	36	46	56
26	20	34	39				
31	25	40	44				
38	30	48	54				
48	40	58	64				
58	50	70	79				
70	60	85	95				

ÖZEL İMALAT / CUSTOM BUILD

## BİLYALI BURÇ / BALL RETAINER

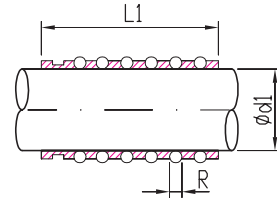

Metal / Steel Alaşımli Bronz Alloyed Bronze		Sertlik Derecesi / Hardness 60-62 HRC								
B B		L1								
d1	R	45	56	71	80	95	105	120	140	160
20	3									
25	3									
30	4									
40	4									
50	4									
60	5									

ÖZEL İMALAT / CUSTOM BUILD

## ŞAPKALI BİLYALI BURÇ / BALL GUIDE BUSH

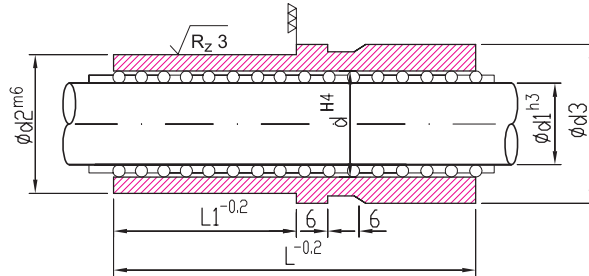

Metal / Steel AISI 8620					Sertlik Derecesi / Hardness 60-62 HRC			
S B B					L1			
d	d1	d2	d3	L	26	36	46	56
26	20	34	39	80				
31	25	40	44	90				
38	30	48	54	100				
48	40	58	64	112				
58	50	70	79	130				
70	60	85	95					

ÖZEL İMALAT / CUSTOM BUILD





## Kolon ve Burçlar Pillar and Bushes

### ŞAPKALI BURÇ / SHOULDER BUSHING

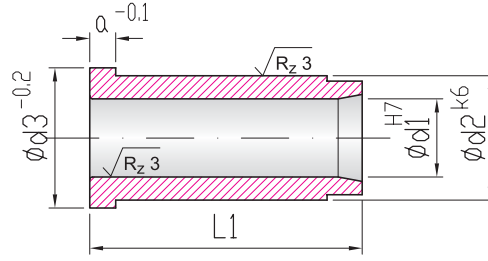

Metal / Steel AISI 7131				Sertlik Derecesi / Hardness 60-62 HRC									
S B				L1									
d1	d2	d3	$\alpha$	26	36	46	56	66	76	86	96	106	116
16	24	28	6										
20	28	32	6										
25	34	38	8										
30	39	43	10										
40	50	54	10	ÖZEL İMALAT / CUSTOM BUILD									

### ŞAPKALI KADEMELİ KOLON / GUIDE PILLAR

Metal / Steel AISI 7131

Sertlik Derecesi / Hardness 60-62 HRC

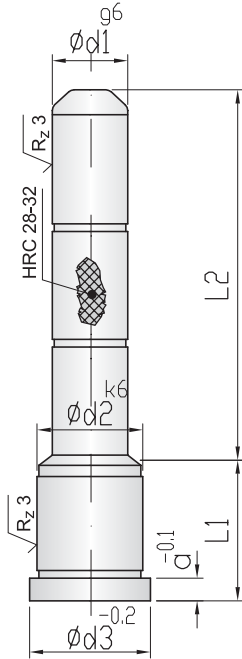

S K K					L2															
D1	D2	D3	$\alpha$	L1	26	36	46	56	66	76	86	96	106	116	126	136	146			
16	24	28	6	26																
				36																
				46																
				56																
				66																
				76																
20	28	32	6	26																
				36																
				46																
				56																
				66																
				76																
25	34	38	8	26																
				36																
				46																
				56																
				66																
				76																
30	39	43	10	26																
				36																
				46																
				56																
				66																
				76																
40	50	54	10	26																
				36																
				46																
				56																
				66																
				76																
					ÖZEL İMALAT / CUSTOM BUILD															
					46															
					56															
					66															
					76															
					86															
					96															
					106															
					116															
					126															



# Kolon ve Burçlar Pillar and Bushes

## DESTEK TESPİT BURCU / CENTERING SLEEVES

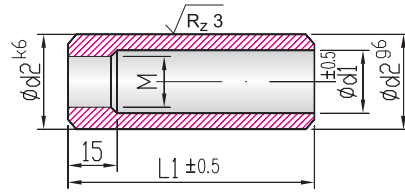

Metal / Steel AISI 7131 Sertlik Derecesi / Hardness 60-62 HRC

D T B			L1					
d1	d2	M	60	80	100	120	140	160
16	24	M8						
20	28	M8						
25	34	M10						
30	39	M10						
40	50	M12	ÖZEL İMALAT / CUSTOM BUILD					

## KUYRUKLU ŞAPKALI BURÇ / LOCATING GUIDE BUSHING

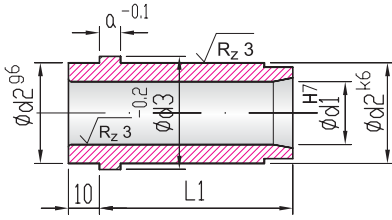

Metal / Steel AISI 7131

Sertlik Derecesi / Hardness 60-62 HRC

K S B				L1									
d1	d2	d3	$\alpha$	26	36	46	56	66	76	86	96	106	116
16	24	28	6										
20	28	32	6										
25	34	38	8										
30	39	43	10										
40	50	54	10	ÖZEL İMALAT / CUSTOM BUILD									

## KUYRUKLU ŞAPKALI KADEMELİ KOLON / LOCATING GUIDE PILLAR

Metal / Steel AISI 7131

Sertlik Derecesi / Hardness 60-62 HRC

K S K K					L2														
D1	D2	D3	$\alpha$	L1	26	36	46	56	66	76	86	96	106	116	126	136	146		
16	24	28	6	26															
				36															
				46															
				56															
				66															
				76															
				86															
				96															
20	28	32	6	26															
				36															
				46															
				56															
				66															
				76															
				86															
				96															
25	34	38	8	26															
				36															
				46															
				56															
				66															
				76															
				86															
				96															
30	39	43	10	26															
				36															
				46															
				56															
				66															
				76															
				86															
				96															
40	50	54	10	26															
				36															
				46															
				56															
				66															
				76															
				86															
				96															
ÖZEL İMALAT / CUSTOM BUILD																			





# OKSET®

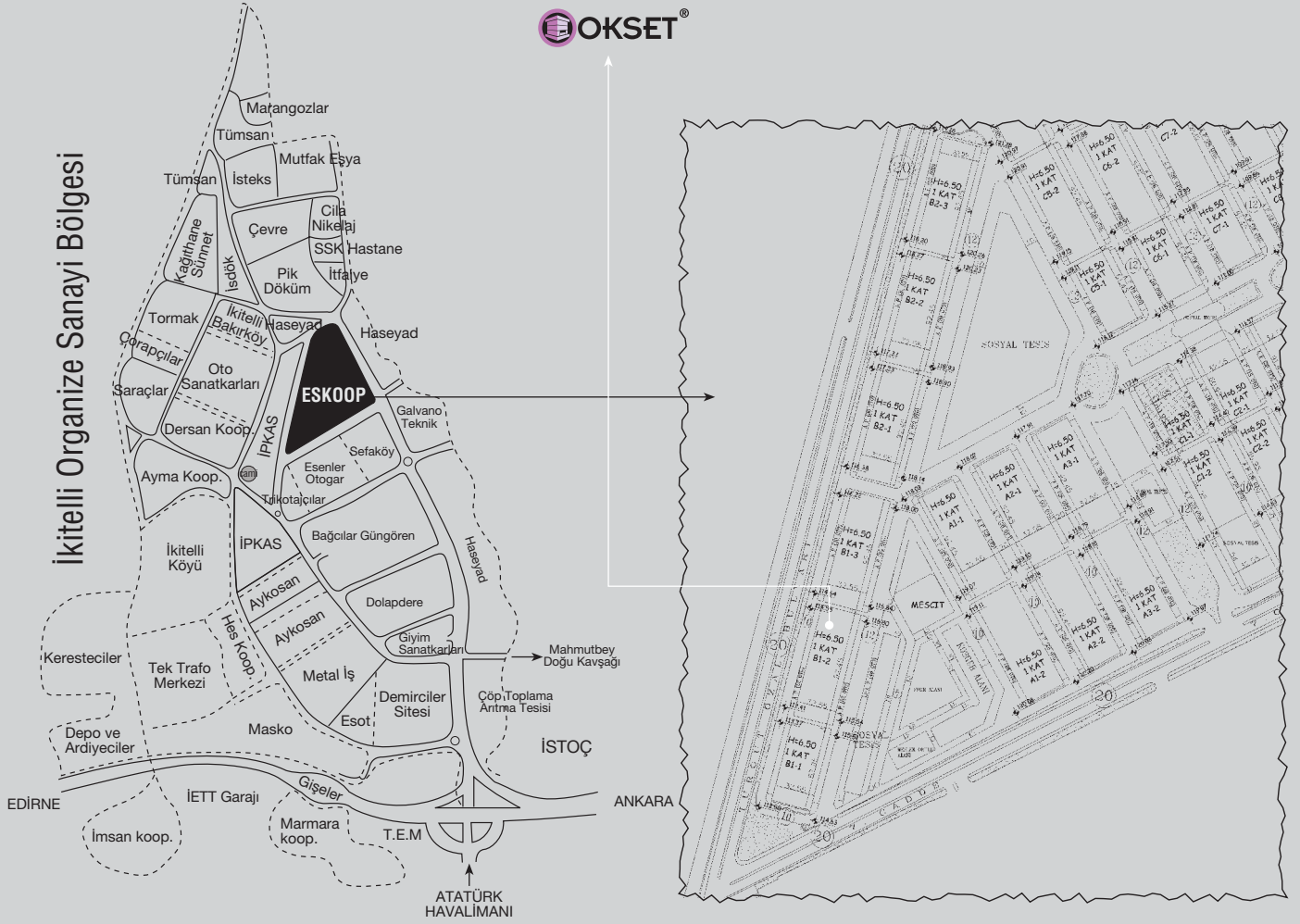

**OKSET Kalıp Elemanları San. ve Tic. A.Ş.**

İkitelli Organize Sanayi Bölgesi

ESKOP Sanayi Sitesi B-2 Blok

No.: 119 - 121 - 123 - 129 - 131 - 133 - 135 - 137

34670 İkitelli - Küçükçekmece / İSTANBUL

Tel. : +90 212 549 37 70 (5 Hat)

Fax : +90 212 549 37 72

e-mail : okset@okset.com

web : www.okset.com